

1 Christina N. Goodrich (SBN 261722)
christina.goodrich@klgates.com
2 Rachel Berman (SBN 352237)
rachel.berman@klgates.com
3 **K&L GATES LLP**
10100 Santa Monica Boulevard, 8th Floor
4 Los Angeles, California 90067
Telephone: (310) 552-5000
5 Fax: (310) 552-5001

6 *Attorneys for Plaintiff Sport Squad, Inc. D/B/A JOOLA*
7

8 UNITED STATES DISTRICT COURT
9 NORTHERN DISTRICT OF CALIFORNIA
10

11 SPORT SQUAD, INC. D/B/A JOOLA

12 Plaintiff,

13 v.

14 FRIDAY LABS LLC

15 Defendant.
16

Case No. 3:26-cv-3069

**COMPLAINT FOR PATENT
INFRINGEMENT OF U.S. PATENT
NO. 12,465,826**

DEMAND FOR JURY TRIAL

17
18
19
20
21
22
23
24
25
26
27
28

1 Plaintiff Sport Squad, Inc. D/B/A JOOLA (“Plaintiff” or “JOOLA”) by and through its
2 undersigned counsel, files this Complaint for Patent Infringement against Defendant Friday Labs
3 LLC (“Friday”) and alleges on knowledge as to its actions, and upon knowledge and information
4 and belief as to the actions of others, as follows:

5 **NATURE OF THE ACTION**

6 1. This action arises under the patent laws of the United States, 35 U.S.C. §§ 1, *et seq.*,
7 from Friday’s infringement of U.S. Patent No. 12,465,826 (the “’826 Patent” or the “Asserted
8 Patent”).

9 **THE PARTIES**

10 2. Plaintiff Sport Squad, Inc. d/b/a JOOLA is a corporation organized under the laws
11 of Maryland with its principal operating business located at 915 Meeting Street, North Bethesda,
12 Maryland 20852.

13 3. Defendant Friday Labs LLC is a limited liability company organized under the laws
14 of California with its principal place of business at 117 Bartlett Street, San Francisco, California
15 94110.

16 4. On information and belief, Friday manufactures, imports, offers for sale, and sells
17 pickleball paddles to resellers, distributors, and consumers throughout the United States, including
18 in this District.

19 **JURISDICTION**

20 5. Subject matter jurisdiction is proper in this Court under 28 U.S.C. §§ 1331 and
21 1338(a) because the claims arise under the patent laws of the United States, 35 U.S.C. § 1 *et seq.*

22 6. This Court has personal jurisdiction over Friday insofar as Friday is organized in
23 this District, and maintains a regular and established place of business at 117 Bartlett Street, San
24 Francisco, California 94110.

25 7. On information and belief, Friday engages in other persistent courses of conduct and
26 derives substantial revenue from products or services and continuous contacts within this District,
27 has purposefully established substantial, systematic, and continuous contacts within this District,
28 and should reasonably expect to be sued in a court in this District.

1 8. On information and belief, Friday regularly transacts business in the State of
2 California and within this District, including a permanent and significant presence in this District.

3 9. The Court’s exercise of jurisdiction over Friday will not offend traditional notions
4 of fair play and substantial justice.

5 **VENUE**

6 10. Venue in this District is proper is proper pursuant to 28 U.S.C. §§ 1391(b), (c) and
7 1400(b).

8 **DIVISIONAL ASSIGNMENT**

9 11. This matter is District-wide and may be properly assigned to any division within the
10 District.

11 **THE PATENT-IN-SUIT**

12 12. On November 11, 2025, the U.S. Patent and Trademark Office (“USPTO”) duly and
13 legally issued the ’826 Patent, entitled “Game Paddle.” A true and correct copy of the ’826 Patent
14 is attached as **Exhibit 1**.

15 **FACTUAL ALLEGATIONS**

16 13. The ’826 Patent describes a solid sports paddle, such as a pickleball paddle, and
17 methods of manufacturing it with internal structures designed to affect the paddle’s feel and
18 performance during play. The technology described in the ’826 Patent is implemented in infringing
19 pickleball paddles including, but not limited to, the Friday Fever 102 (“Accused Product”).

20 14. Friday has infringed and continues to infringe the ’826 Patent by making, using,
21 selling, offering to sell, and/or importing products including, but not limited to, the Friday Fever
22 102.

23 15. Throughout its infringement, Friday has had actual knowledge of JOOLA’s ’826
24 Patent and of Friday’s infringement of the ’826 Patent.

25 **COUNT I: INFRINGEMENT OF THE ’826 PATENT**

26 16. JOOLA realleges and incorporates by reference each of its allegations in paragraphs
27 1-14 of this Complaint.
28

1 17. JOOLA has not licensed or otherwise authorized Friday to make, use, offer for sale,
2 sell, or import any products that embody the inventions of the '826 Patent.

3 18. As shown in the attached non-limiting claim chart (**Exhibit 2**), by making, using (at
4 least by testing), selling, offering for sale, and/or importing the Accused Product in this Judicial
5 District and throughout the United States without license or authorization, Friday is now and has
6 been directly infringing at least claim 1 of the '826 Patent, either literally or under the doctrine of
7 equivalents, as proscribed by 35 U.S.C. § 271, *et seq.*

8 19. Exhibit 2 is intended solely to satisfy the notice requirements of Federal Rule of
9 Civil Procedure 8(a)(2), and does not represent JOOLA's preliminary or final infringement
10 contentions or preliminary or final claim construction positions. JOOLA reserves the right to
11 modify its infringement theories reflected in Exhibit 2 as discovery progresses in this case,
12 including through contentions disclosures and claim construction in accordance with the Patent
13 Local Rules in this District.

14 20. As a direct and proximate result of Friday's direct infringement of the '826 Patent,
15 JOOLA has been and continues to be damaged. Friday's infringing activities will continue unless
16 enjoined by this Court or until the patent expires, whichever is sooner.

17 21. By engaging in the conduct described herein, Friday has injured JOOLA and is thus
18 liable for infringement of the '826 Patent, pursuant to 35 U.S.C. § 271.

19 22. Friday has committed and continues to commit acts of infringement that Friday
20 actually knew or should have known constituted an unjustifiably high risk of infringement of at
21 least one valid and enforceable claim of the '826 Patent. Friday's direct infringement of the '826
22 Patent has been and continues to be willful, intentional, deliberate, or in conscious disregard of
23 rights under the patent. JOOLA is entitled to an award of treble damages, reasonable attorney fees,
24 and costs in bringing this action

25 **PRAYER FOR RELIEF**

26 WHEREFORE, JOOLA prays for the following relief against Friday as follows:

27 A. Entry of judgment declaring that Friday has infringed one or more claims of the '826 Patent;
28

- 1 B. Entry of judgment declaring that Friday’s infringement of the ’826 Patent has been willful
2 and deliberate;
- 3 C. An order pursuant to 35 U.S.C. § 283 permanently enjoining Friday, their officers, agents,
4 servants, employees, attorneys, and those persons in active concert or participation with
5 them, from further acts of infringement of the ’826 Patent;
- 6 D. An order awarding damages sufficient to compensate JOOLA for Friday’s infringement of
7 the ’826 Patent, but in no event less than a reasonable royalty, together with interest and
8 costs;
- 9 E. An order awarding JOOLA treble damages under 35 U.S.C. § 284 as a result of Friday’s
10 willful and deliberate infringement of the ’826 Patent;
- 11 F. Entry of judgment declaring that this case is exceptional and awarding JOOLA its costs and
12 reasonable attorney fees under 35 U.S.C. § 285; and
- 13 G. Such other and further relief as this Court may deem just and proper.

14 **JURY DEMAND**

15 JOOLA hereby demands a trial by jury on all issues so triable.

16
17
18 Dated: April 9, 2026

Respectfully submitted,

19 /s/ Christina N. Goodrich

20 Christina N. Goodrich (SBN 261722)

christina.goodrich@klgates.com

21 Rachel Berman (SBN 352237)

rachel.berman@klgates.com

22 K&L GATES LLP

10100 Santa Monica Boulevard, 8th Floor

23 Los Angeles, California 90067

Telephone: (310) 552-5000

24 Fax: (310) 552-5001

25 Nicholas F. Lenning (*pro hac vice*
forthcoming)

26 nicholas.lenning@klgates.com

K&L Gates LLP

27 925 Fourth Avenue, Suite 2900

Seattle, Washington 98104

28 Telephone: (206) 623-7580

1
2
3
4
5
6
7
8
9
10
11
12
13
14
15
16
17
18
19
20
21
22
23
24
25
26
27
28

Jason A. Engel (*pro hac vice forthcoming*)
jason.engel@klgates.com
Austin C. Holler (*pro hac vice forthcoming*)
austin.holler@klgates.com
Devdhi Kasana (*pro hac vice forthcoming*)
devdhi.kasana@klgates.com
Kahlan E. Noel (*pro hac vice forthcoming*)
kahlan.noel@klgates.com
K&L Gates LLP
70 W. Madison Street, Suite 3300
Chicago, Illinois 60602
Telephone: (312) 372-1121

*Attorneys for Plaintiff Sport Squad, Inc. D/B/A
JOOLA*

EXHIBIT 1



(12) **United States Patent**
Kachiwazaki et al.

(10) **Patent No.:** **US 12,465,826 B2**
(45) **Date of Patent:** **Nov. 11, 2025**

(54) **GAME PADDLE**

(71) Applicant: **Sport Squad, Inc.**, Rockville, MD (US)

(72) Inventors: **Fabio Kachiwazaki**, São Paulo (BR);
Austin Kim, Columbia, MD (US);
Richard Lee, Potomac, MD (US)

(73) Assignee: **Sport Squad, Inc.**, North Bethesda, MD (US)

(*) Notice: Subject to any disclaimer, the term of this patent is extended or adjusted under 35 U.S.C. 154(b) by 0 days.

(21) Appl. No.: **19/027,671**

(22) **Filed:** **Jan. 17, 2025**

(65) **Prior Publication Data**
US 2025/0161771 A1 May 22, 2025

Related U.S. Application Data

(63) Continuation of application No. 18/389,174, filed on Nov. 13, 2023.
(Continued)

(51) **Int. Cl.**
A63B 59/42 (2015.01)
A63B 60/54 (2015.01)
(Continued)

(52) **U.S. Cl.**
CPC **A63B 59/42** (2015.10); **B32B 3/08** (2013.01); **B32B 3/12** (2013.01); **B32B 5/02** (2013.01); **B32B 5/18** (2013.01); **A63B 60/54** (2015.10); **A63B 2209/02** (2013.01); **B32B 2262/106** (2013.01); **B32B 2266/0214** (2013.01)

(58) **Field of Classification Search**

CPC **B32B 3/08**; **B32B 3/12**; **B32B 5/18**; **B32B 2262/106**; **B32B 2266/0214**; **A63B 59/42**; **A63B 2209/00**; **A63B 2209/02**; **A63B 60/54**

See application file for complete search history.

(56) **References Cited**

U.S. PATENT DOCUMENTS

3,879,035 A * 4/1975 Danchulis A63B 59/40 473/527
3,949,988 A 4/1976 Stauffer
(Continued)

FOREIGN PATENT DOCUMENTS

CA 3038087 A 9/2020
CN 219167665 U 6/2023
(Continued)

OTHER PUBLICATIONS

Image of cutaway of Selkirk LABS Project 002 paddle (Aug. 2023), 1 page.

(Continued)

Primary Examiner — Eugene L Kim
Assistant Examiner — Amir A Klayman
(74) *Attorney, Agent, or Firm* — Bass Patent Law, LLC

(57) **ABSTRACT**

The present teachings generally include game paddles such as pickleball paddles. For example, a pickleball paddle disclosed herein may include a first surface, a second surface, and a core disposed therebetween, where the core defines a plurality of gaps that can accommodate one or more fillers, e.g., to provide vibration dampening and/or to otherwise affect performance, comfort, and enjoyment. In some aspects, a frame may also or instead include a filler disposed therein and/or adjacent thereto.

20 Claims, 31 Drawing Sheets

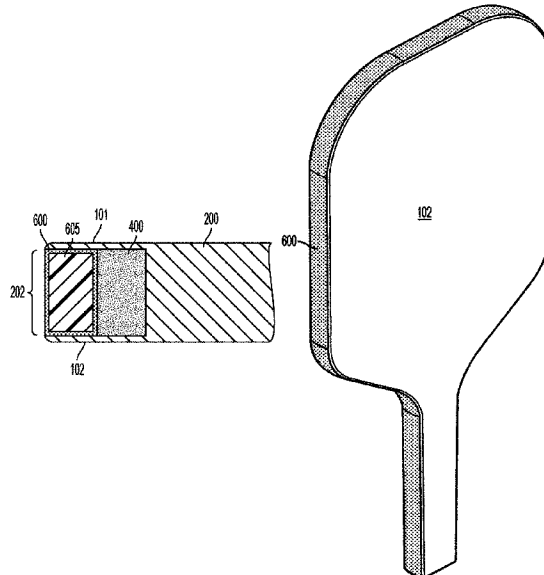

US 12,465,826 B2

Related U.S. Application Data

(60) Provisional application No. 63/543,865, filed on Oct. 12, 2023, provisional application No. 63/535,565, filed on Aug. 30, 2023.

(51) **Int. Cl.**
B32B 3/08 (2006.01)
B32B 3/12 (2006.01)
B32B 5/02 (2006.01)
B32B 5/18 (2006.01)

References Cited

U.S. PATENT DOCUMENTS

4,130,277 A 12/1978 Marks
4,192,506 A * 3/1980 Sofia A63B 60/00
473/548
4,194,738 A * 3/1980 Inoue A63B 49/10
473/535
4,227,692 A * 10/1980 Castelli A63B 60/40
473/525
4,331,331 A * 5/1982 Rodgers, Jr. A63B 60/00
473/544
4,379,554 A 4/1983 Schuyler et al.
5,172,911 A * 12/1992 Chang A63B 60/00
473/521
5,454,562 A * 10/1995 Sommer A63B 60/54
473/523
5,649,873 A * 7/1997 Fuller A63B 53/0466
473/332
5,961,404 A 10/1999 Gormley
9,993,707 B2 * 6/2018 Davis A63B 60/00
10,377,093 B2 8/2019 Filippini
11,597,169 B2 3/2023 Simmons
11,612,792 B2 3/2023 Marshall
12,370,424 B1 * 7/2025 Kim B32B 5/18
2011/0201461 A1 8/2011 Gazzara et al.
2015/0224370 A1 * 8/2015 Yamamoto A63B 49/10
156/185
2017/0021247 A1 * 1/2017 Marvin A63B 59/40
2017/0021248 A1 * 1/2017 Marvin A63B 59/45
2017/0136325 A1 * 5/2017 Fox A63B 59/42
2018/0104555 A1 * 4/2018 Taylor A63B 59/45
2018/0353820 A1 * 12/2018 Davis A63B 59/70
2020/0290243 A1 9/2020 Avnery et al.
2020/0360778 A1 * 11/2020 Lee A63B 60/04

2020/0398130 A1 * 12/2020 Lee A63B 59/42
2021/0252356 A1 8/2021 Thurman et al.
2021/0252357 A1 * 8/2021 Lee A63B 59/42
2021/0260452 A1 8/2021 Zheng
2022/0032141 A1 2/2022 Brents et al.
2022/0040937 A1 2/2022 Simmons
2023/0047371 A1 * 2/2023 Lee A63B 60/00
2023/0149784 A1 5/2023 Lee
2023/0191215 A1 * 6/2023 Barnes A63B 59/42
473/527
2023/0356048 A1 11/2023 Junkins
2023/0415010 A1 * 12/2023 Luo A63B 59/42
2024/0050822 A1 2/2024 Kapheim
2024/0165468 A1 5/2024 Shu
2024/0424366 A1 * 12/2024 Li A63B 59/48
2025/0018264 A1 * 1/2025 Filippini A63B 60/08
2025/0083010 A1 * 3/2025 Meyer B32B 27/12
2025/0114674 A1 * 4/2025 Hudes A63B 59/42
2025/0161772 A1 5/2025 Kachiwazaki et al.

FOREIGN PATENT DOCUMENTS

CN 219701015 U 9/2023
WO WO-2022182992 A1 * 9/2022 A63B 59/42
WO 2022217045 A1 10/2022
WO WO-2024076417 A1 * 4/2024
WO 2025049122 A1 3/2025

OTHER PUBLICATIONS

Selkirk LABS Project 002, website captured by Wayback Machine on Jun. 2, 2022, currently available at <https://www.selkirklabs.com/products/selkirk-labs-project-002> (website capture date is Jun. 2, 2022), 3 pages.
U.S. Appl. No. 63/535,565, filed Aug. 30, 2023, Fabio Kachiwazaki.
U.S. Appl. No. 63/543,865, filed Oct. 12, 2023, Fabio Kachiwazaki.
Gearbox, "Pro Power Elongated," <https://gearboxsports.com/collections/all-pickleball-paddles/products/pro-power-elongated>, 2023, 9 pages.
ISA/EP, PCT Application No. PCT/US24/42535, International Search Report and Written Opinion dated Nov. 12, 2024, 15 pages.
U.S. Appl. No. 19/028,832, Non-Final Office Action dated Mar. 12, 2025, 15 pages.
U.S. Appl. No. 19/028,832, Notice of Allowance dated Apr. 9, 2025, 9 pages.

* cited by examiner

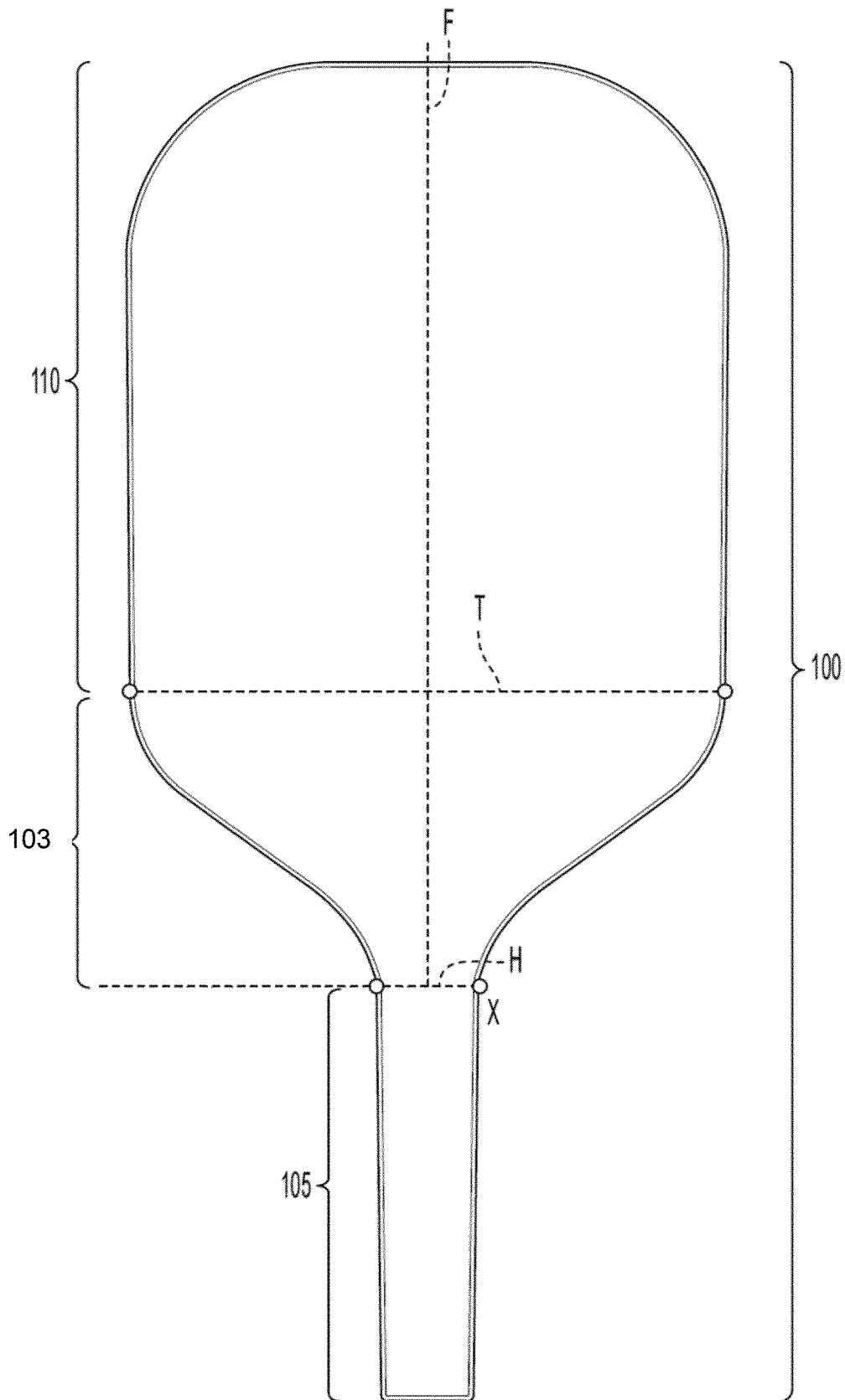

FIG. 1A

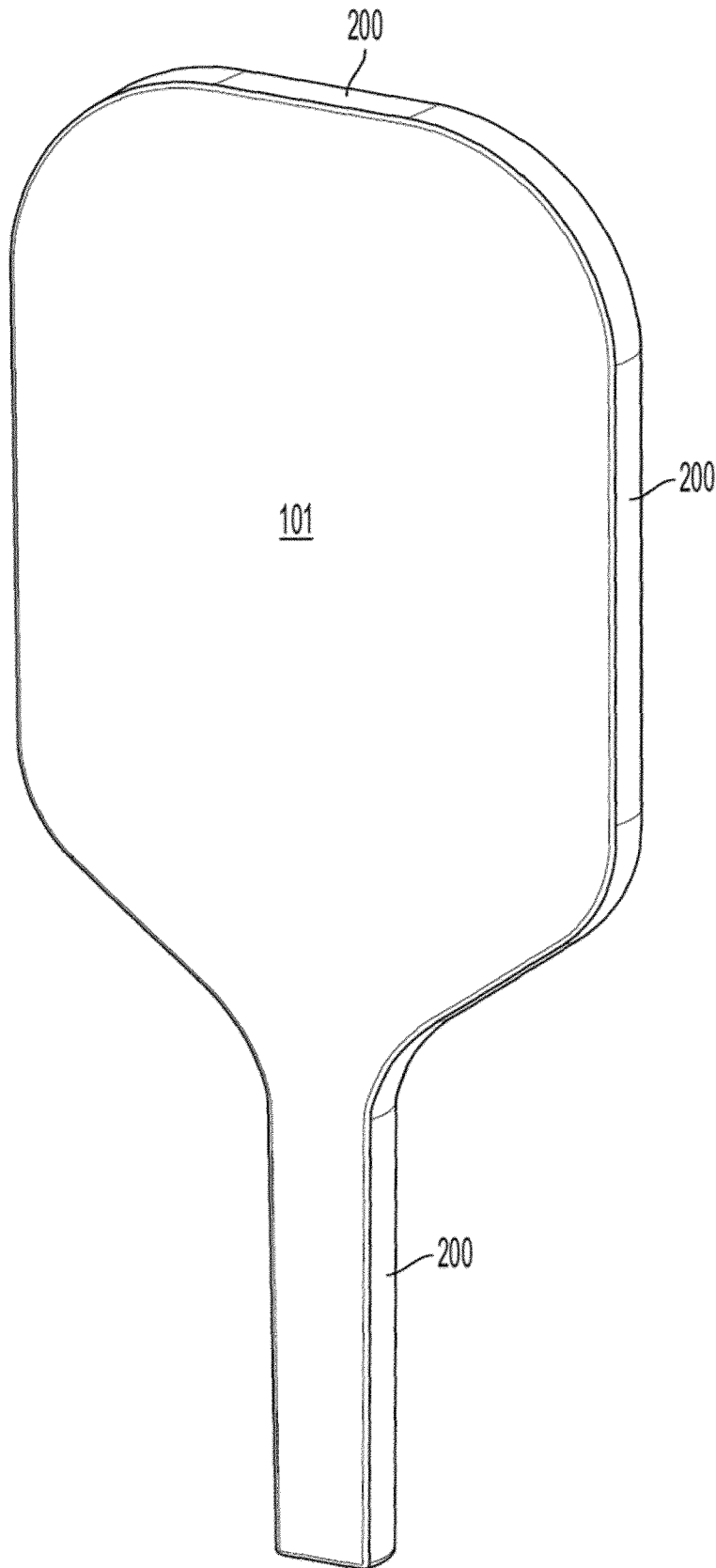

FIG. 1B

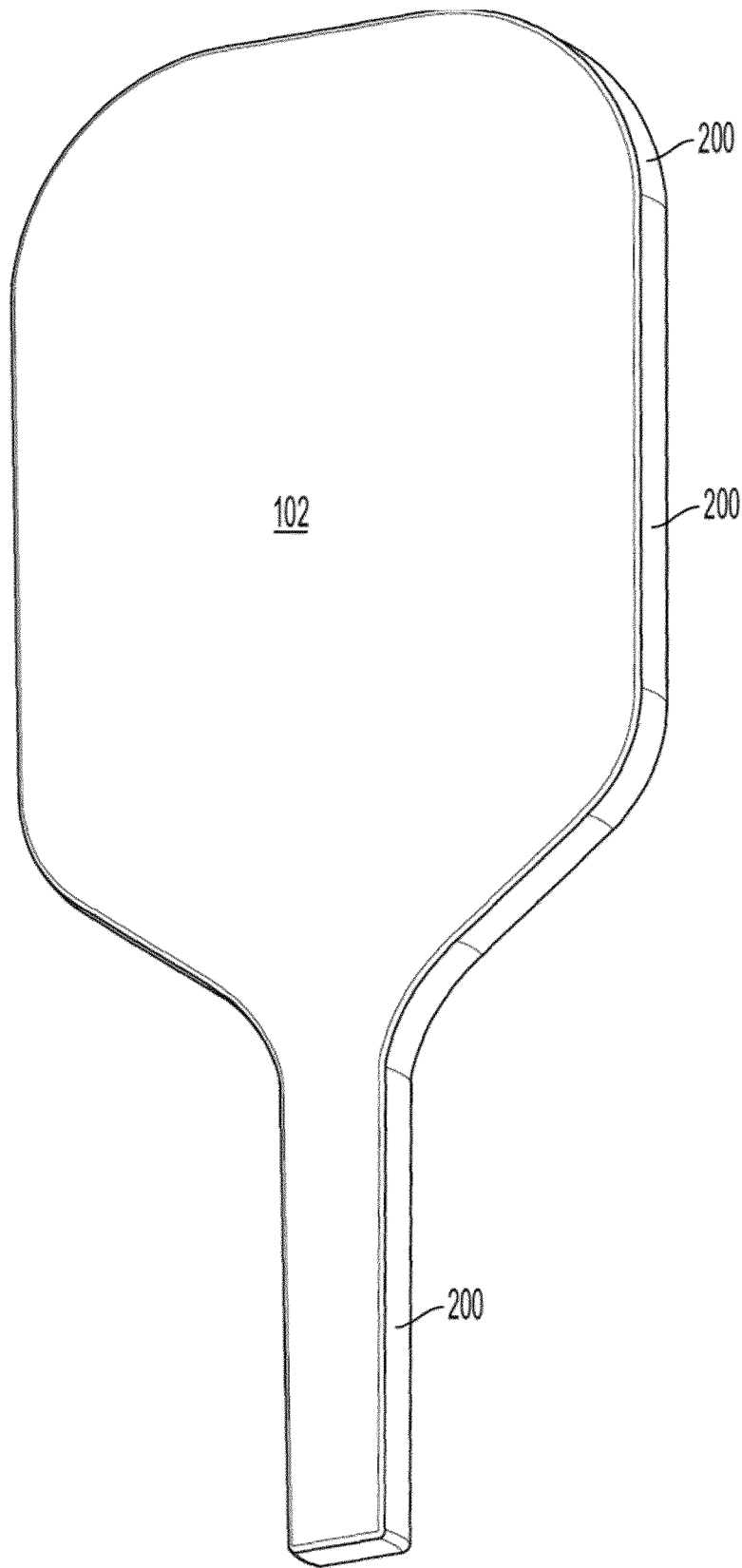

FIG. 1C

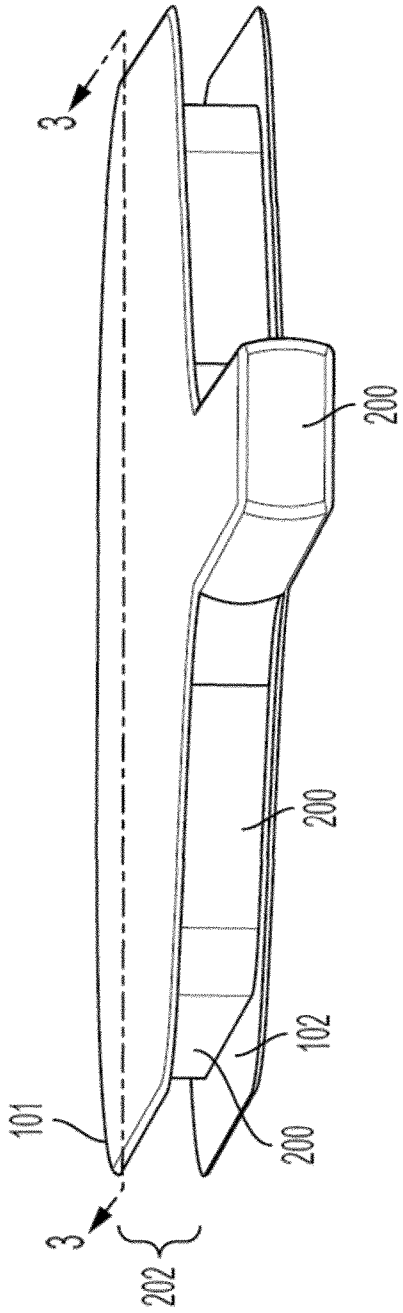

FIG. 2

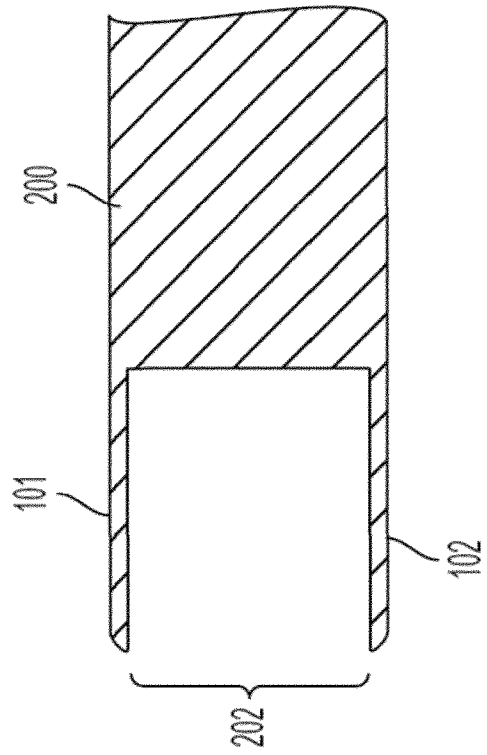

FIG. 3

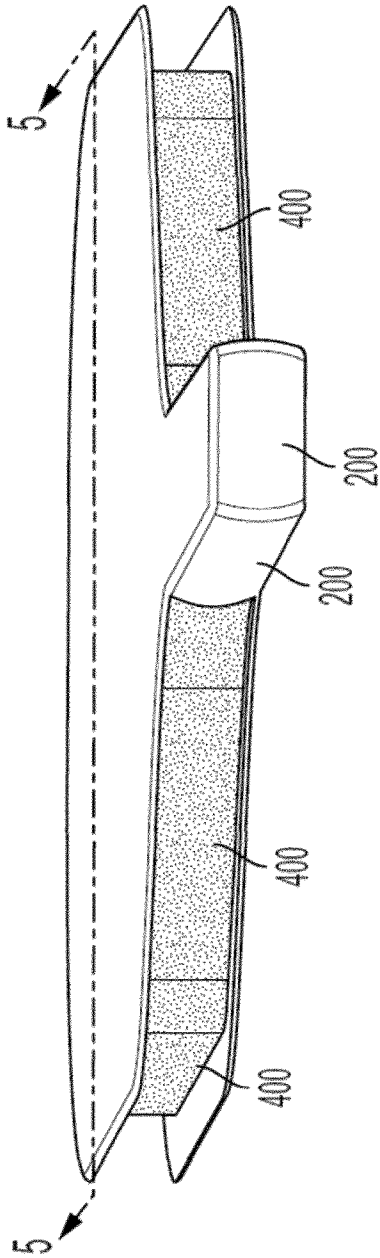

FIG. 4

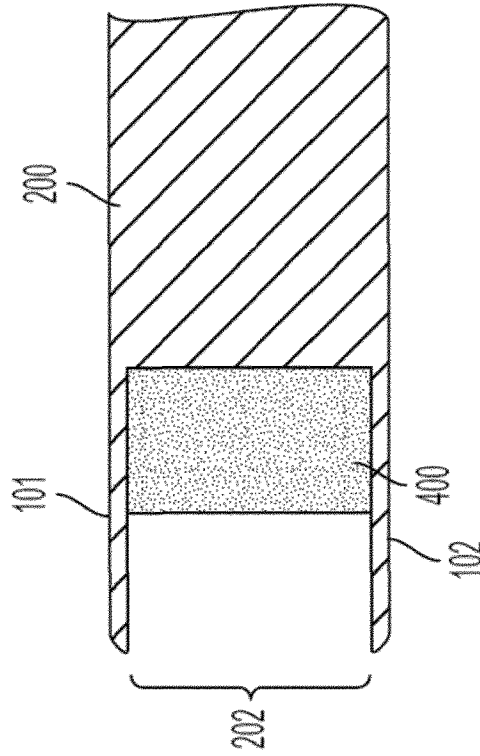

FIG. 5

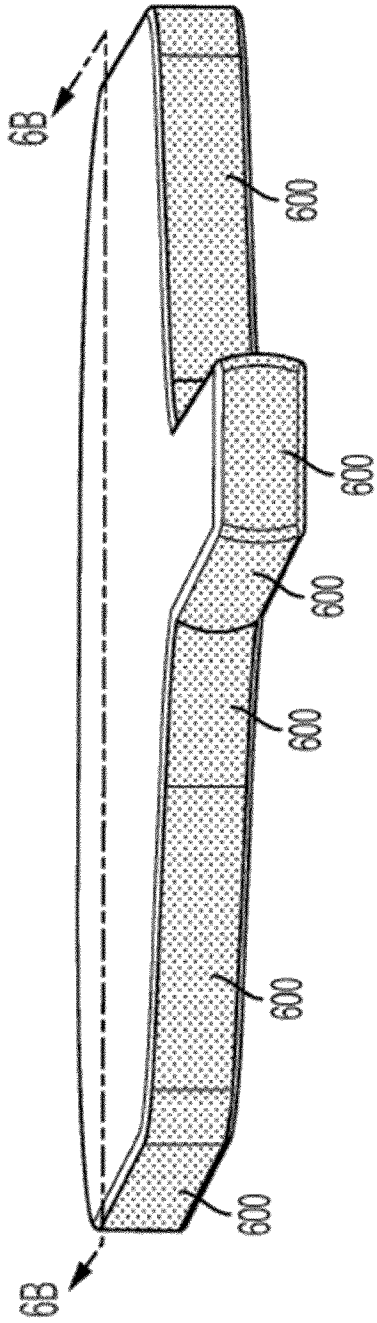

FIG. 6A

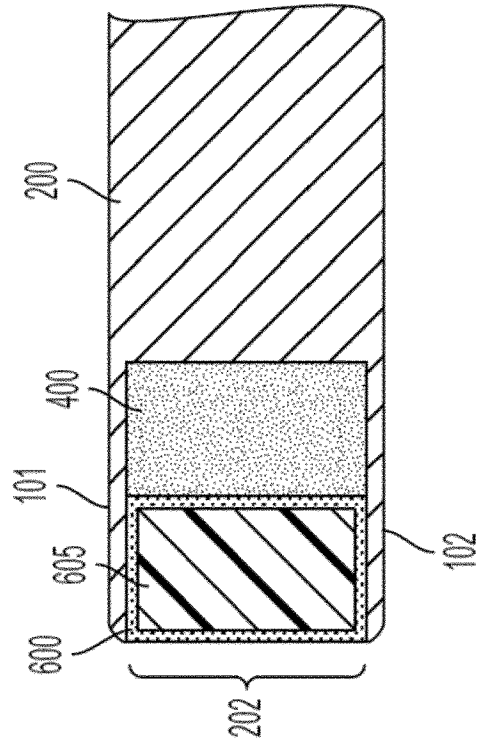

FIG. 6B

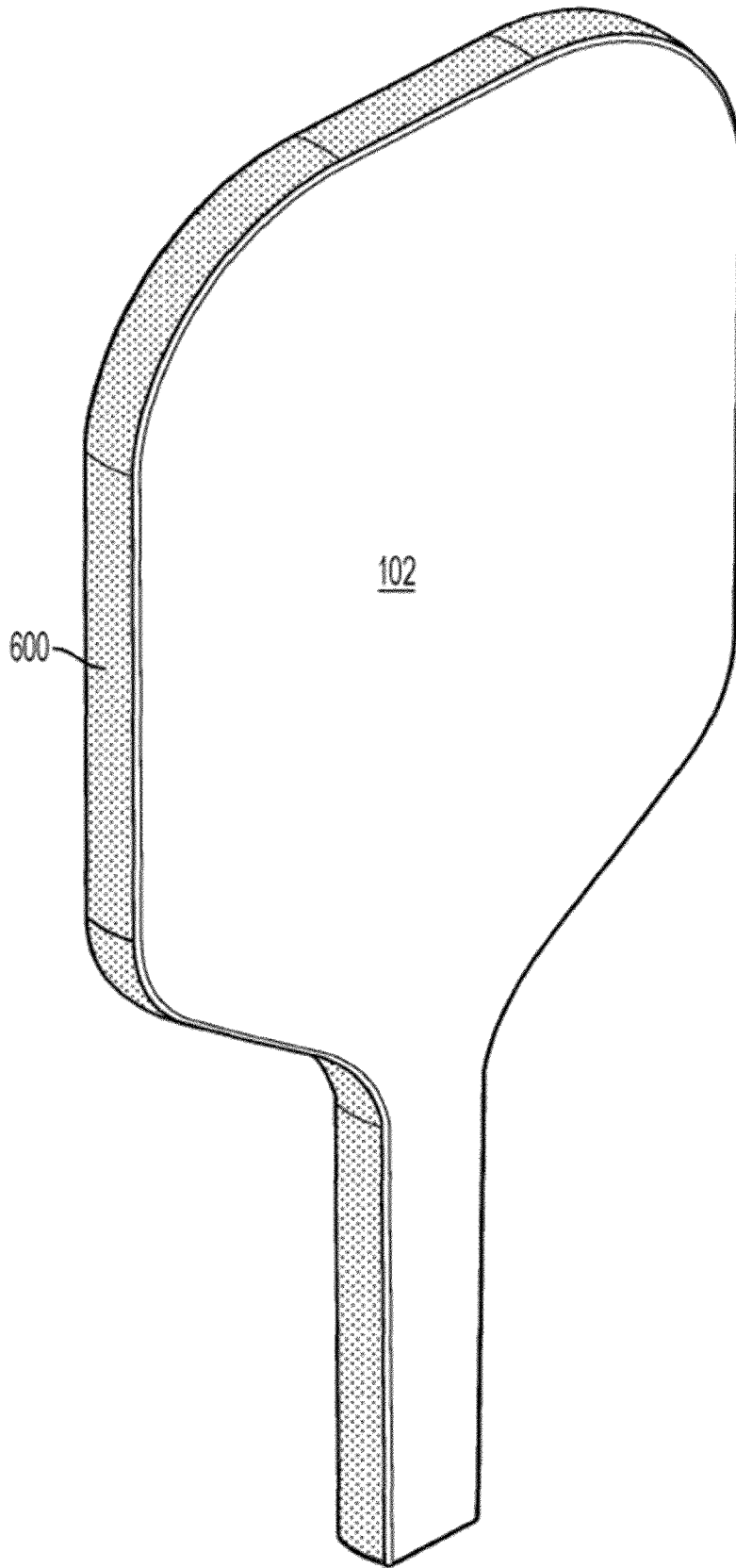

FIG. 7A

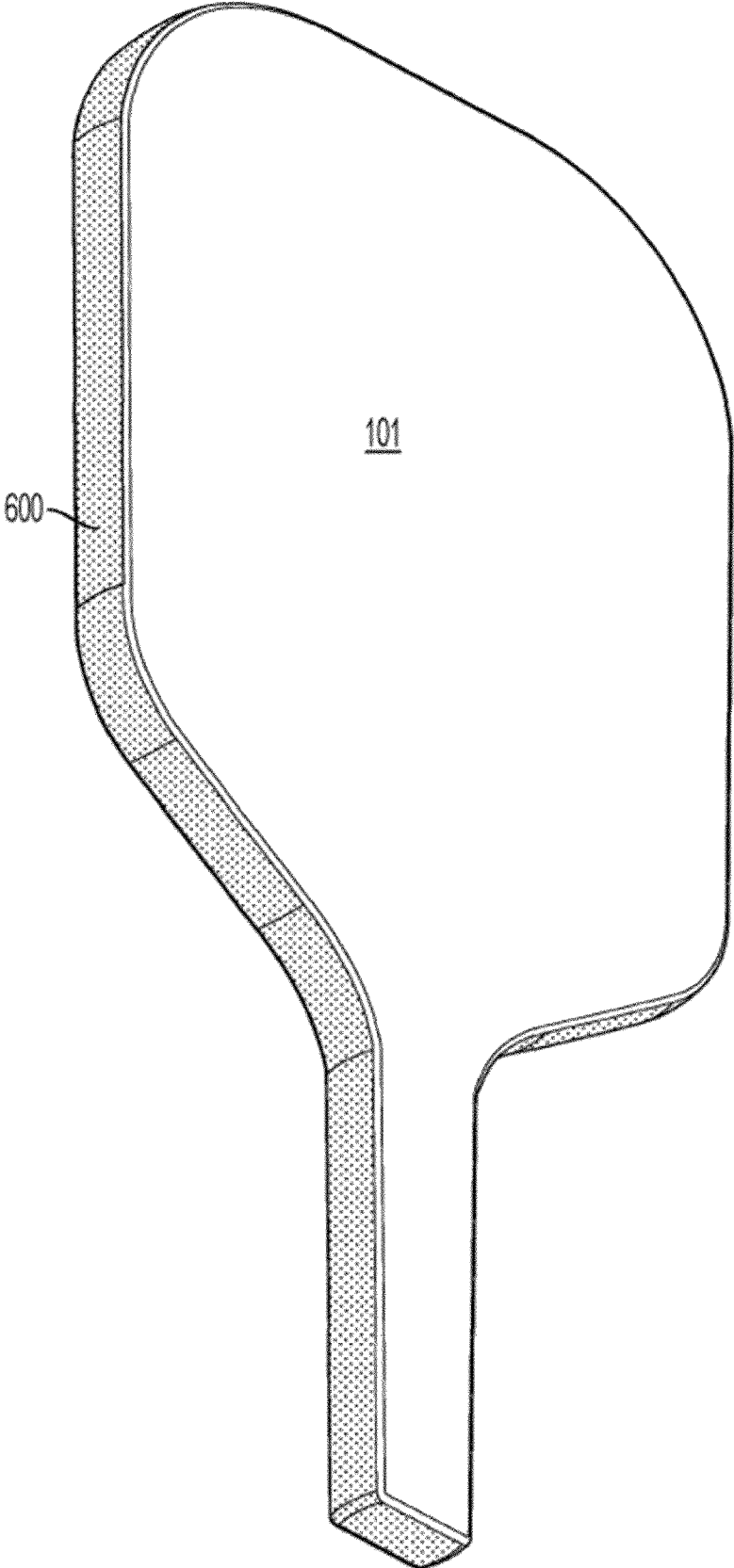

FIG. 7B

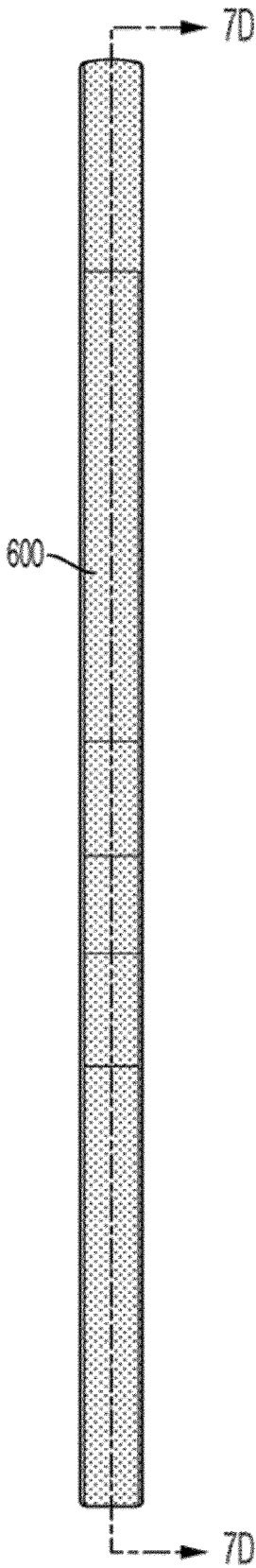

FIG. 7C

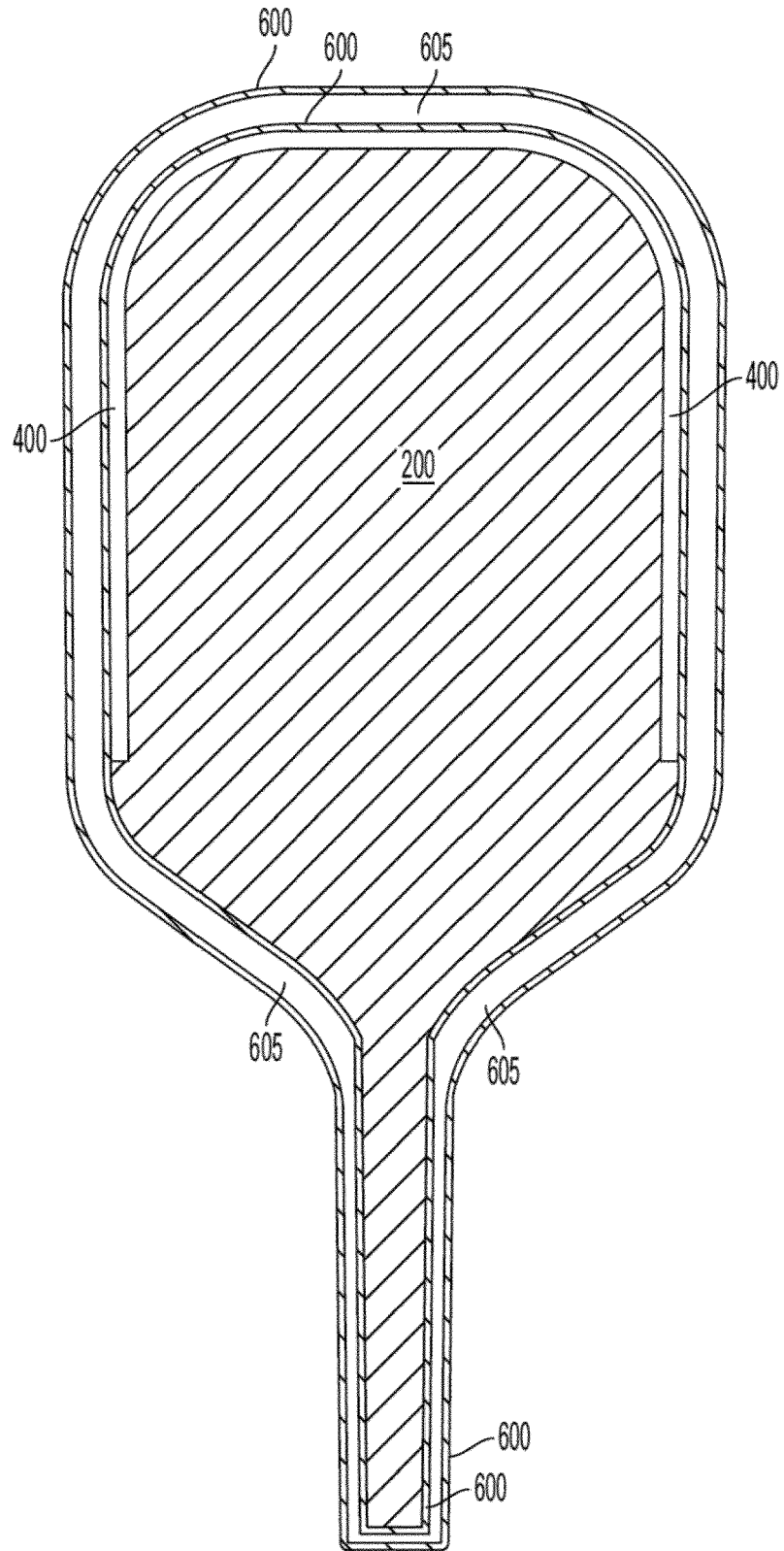

FIG. 7D

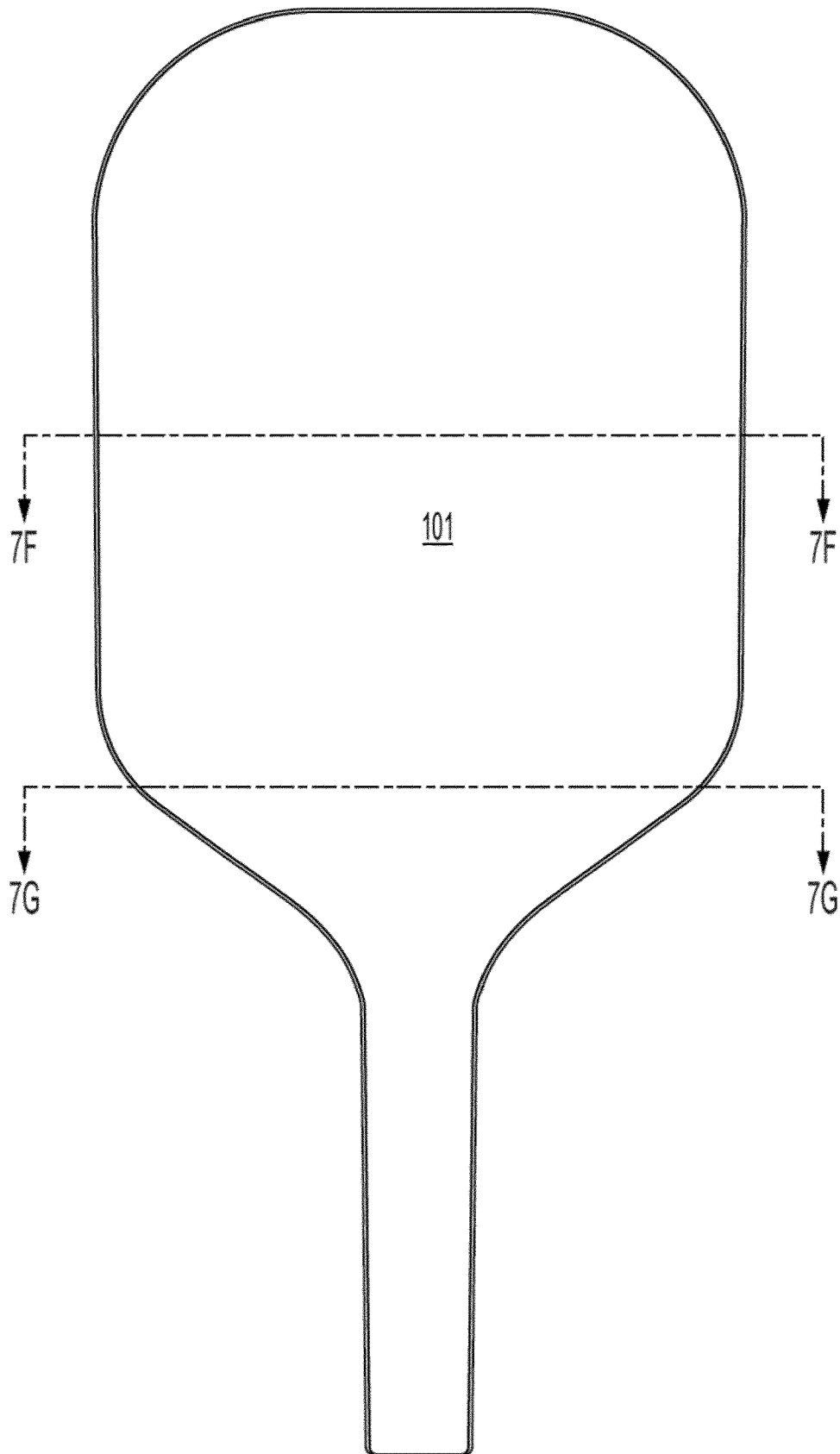

FIG. 7E

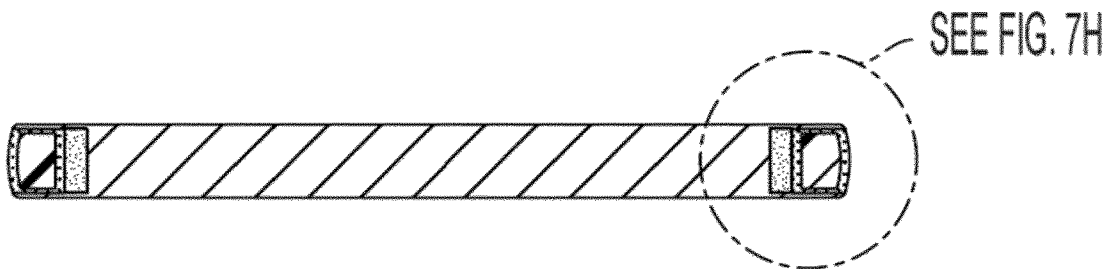

FIG. 7F

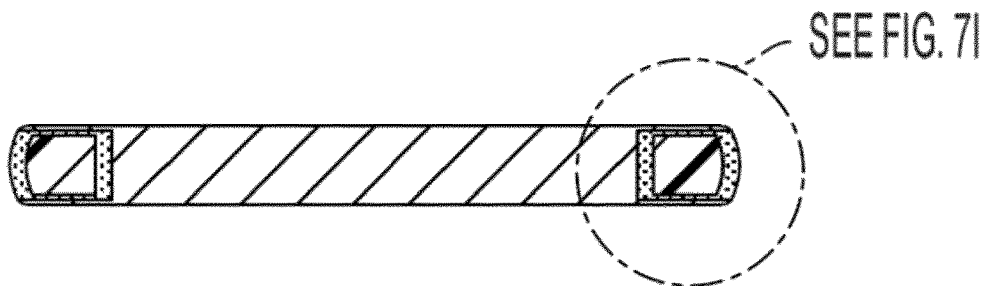

FIG. 7G

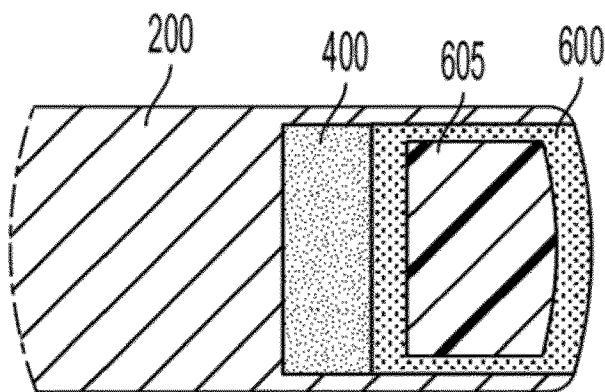

FIG. 7H

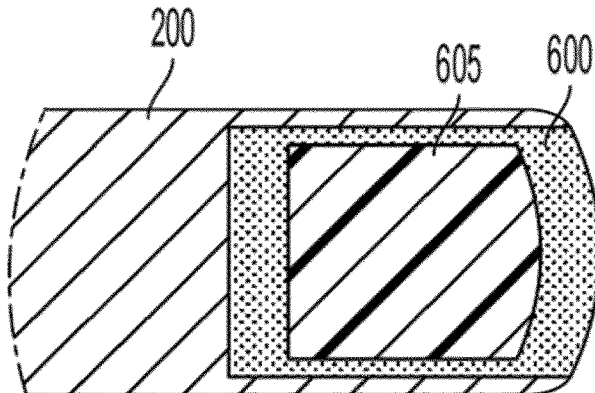

FIG. 7I

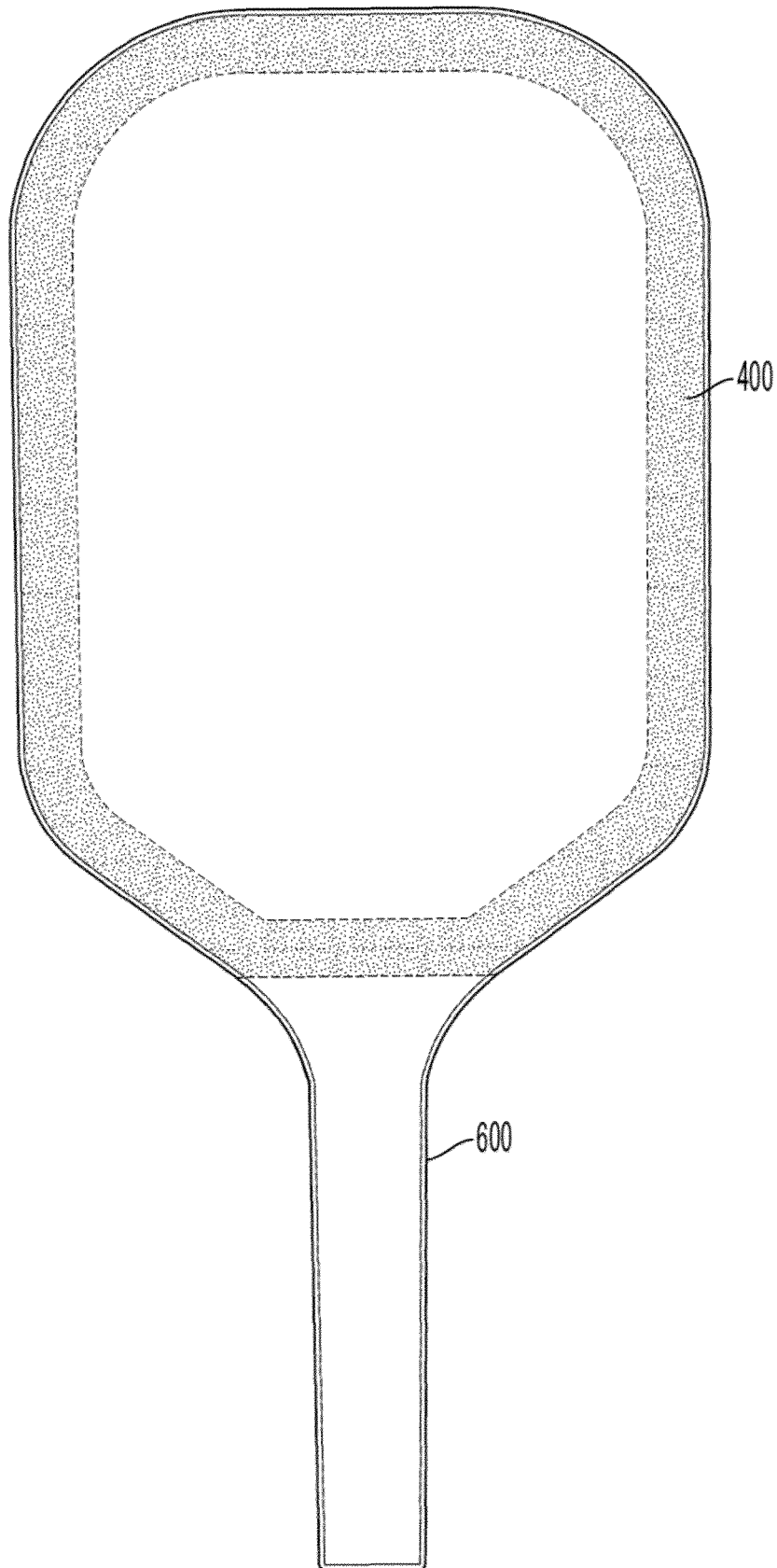

FIG. 8

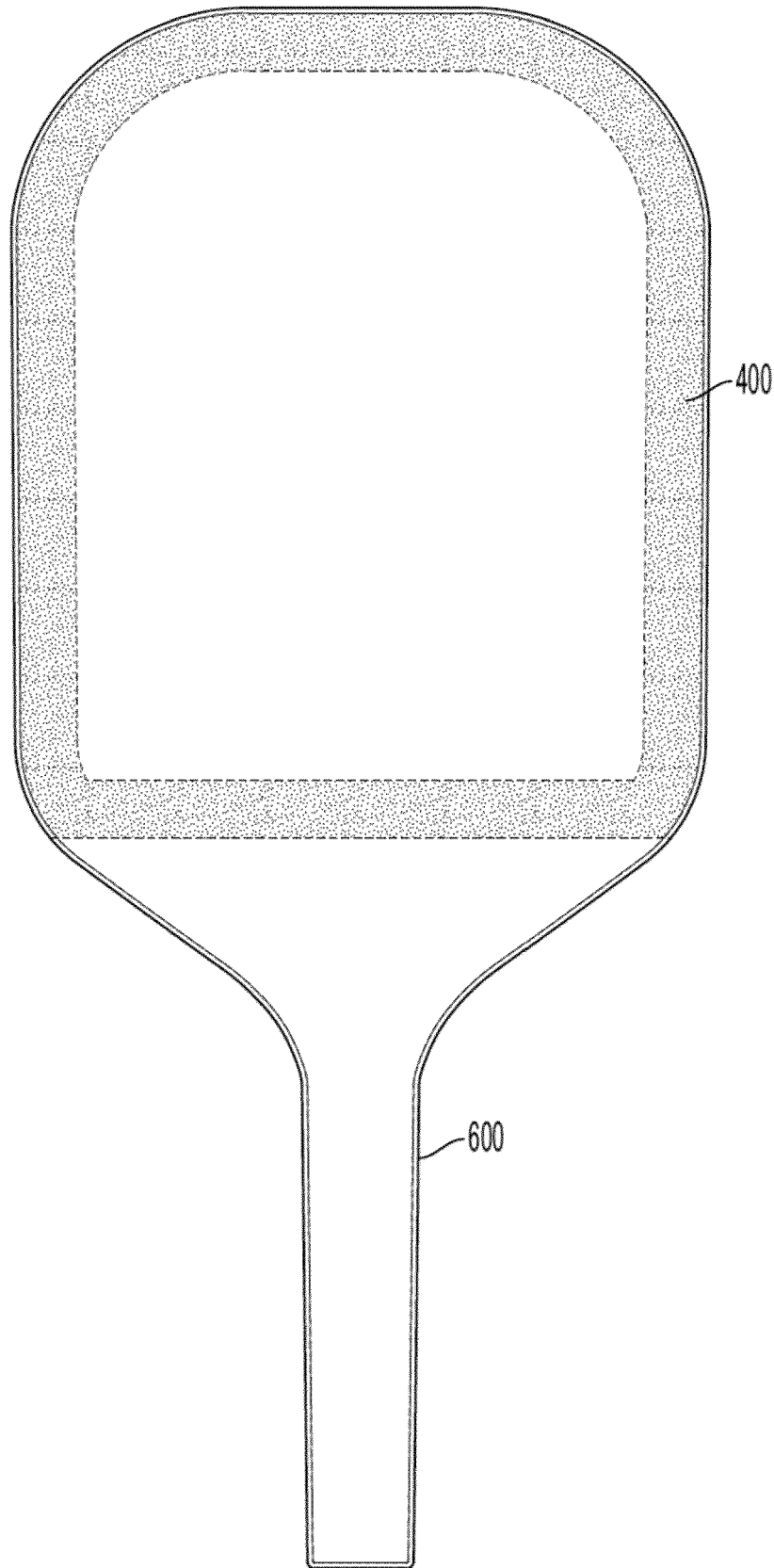

FIG. 9

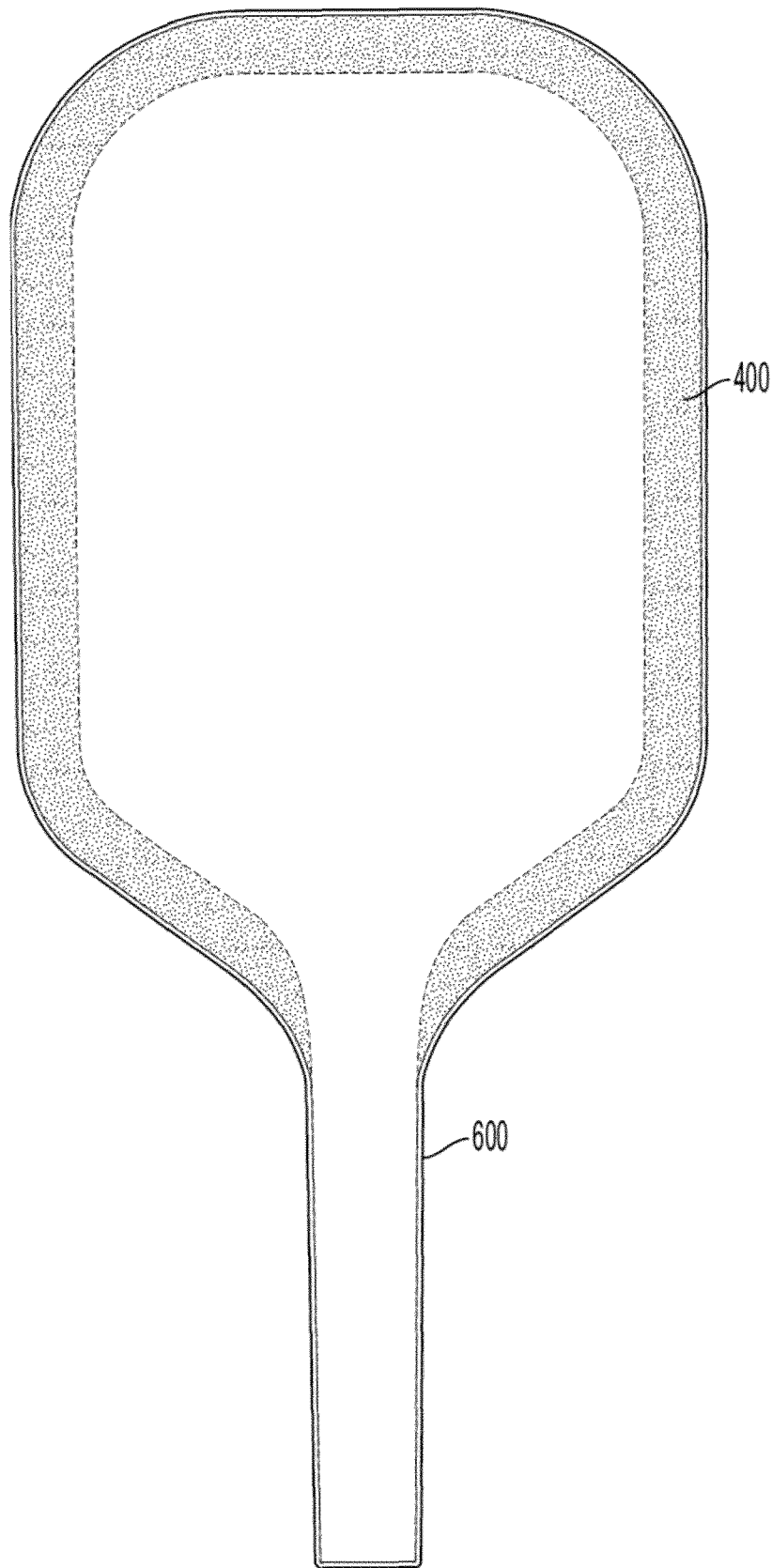

FIG. 10

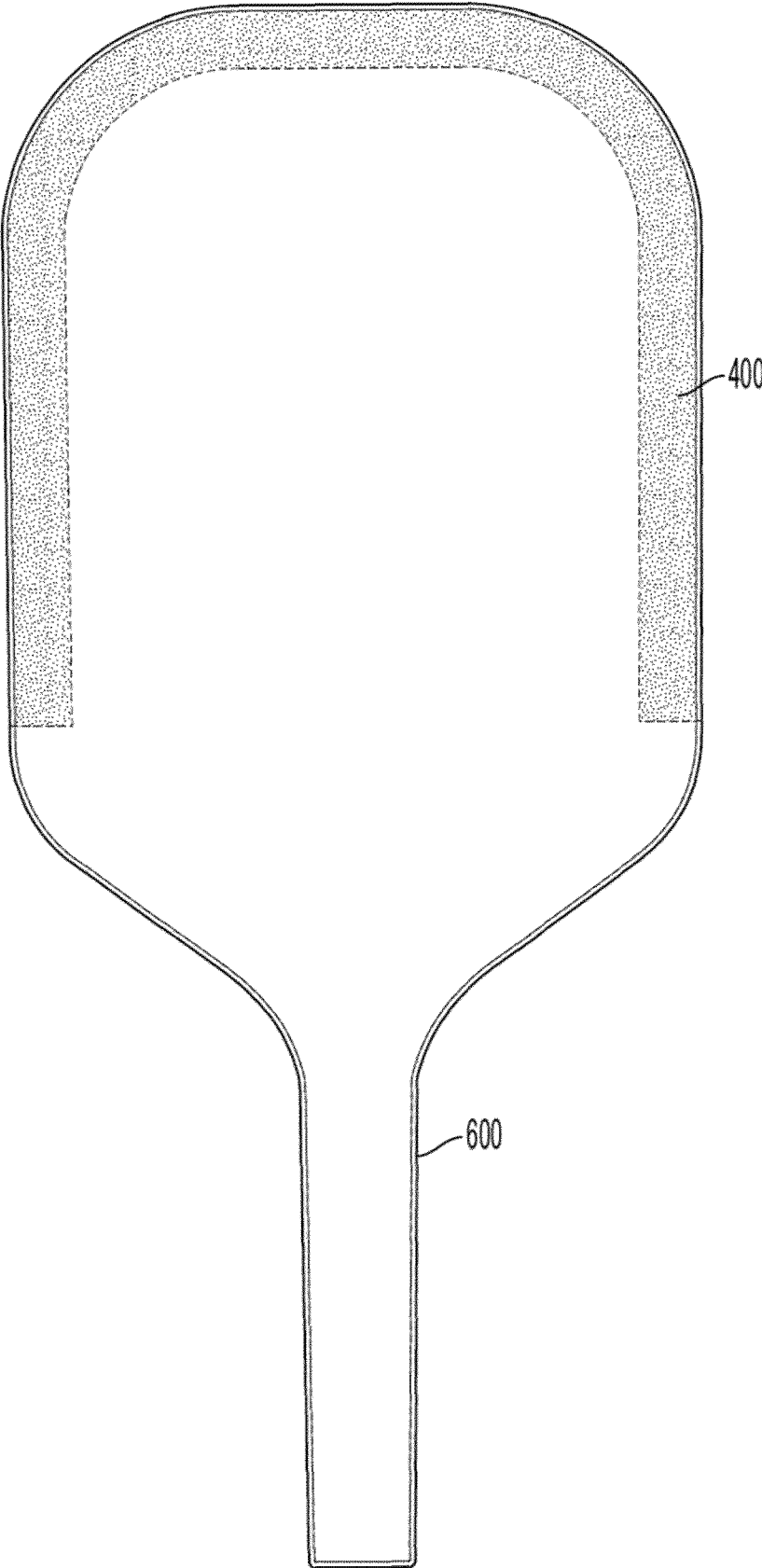

FIG. 11

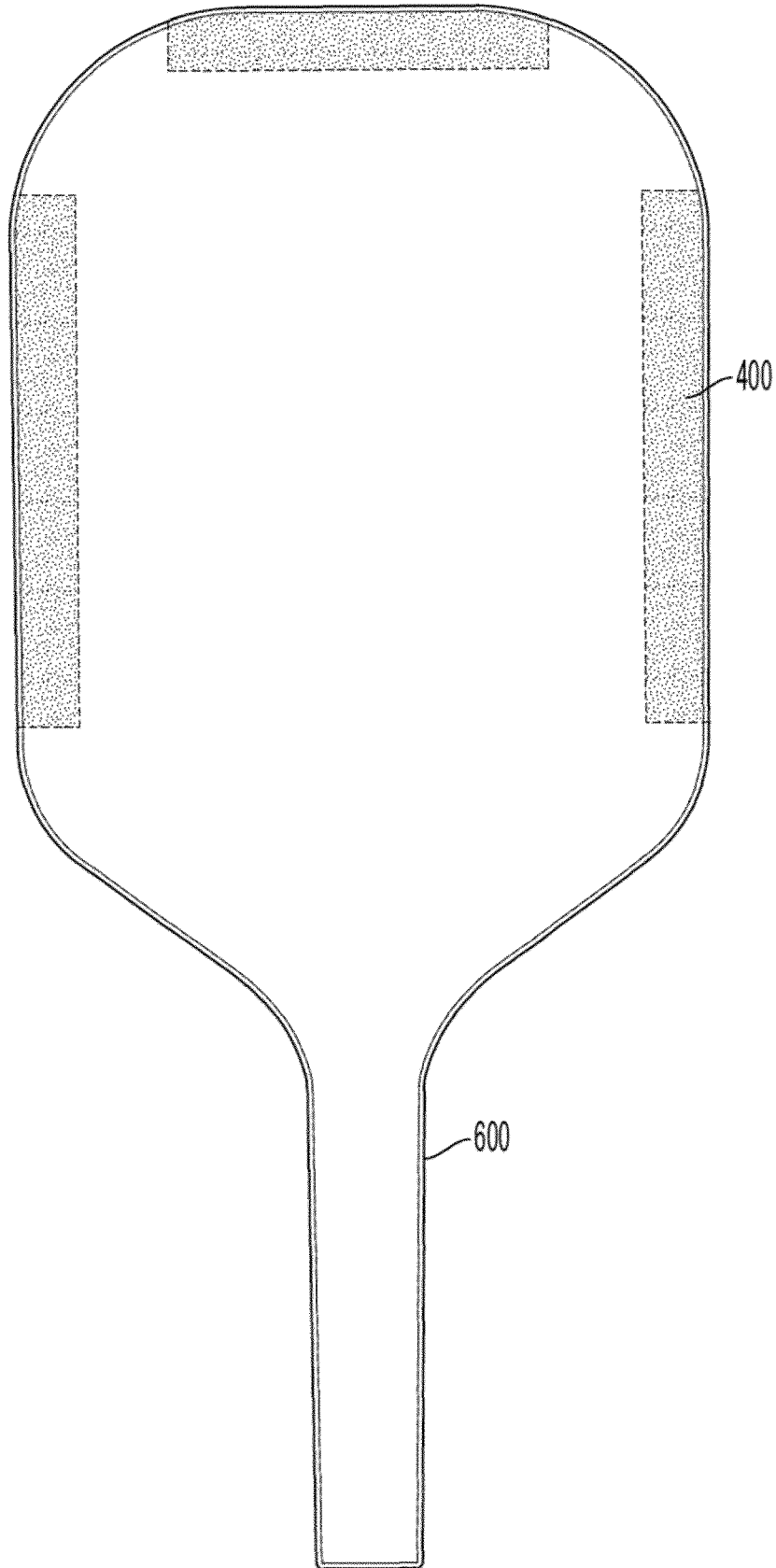

FIG. 12

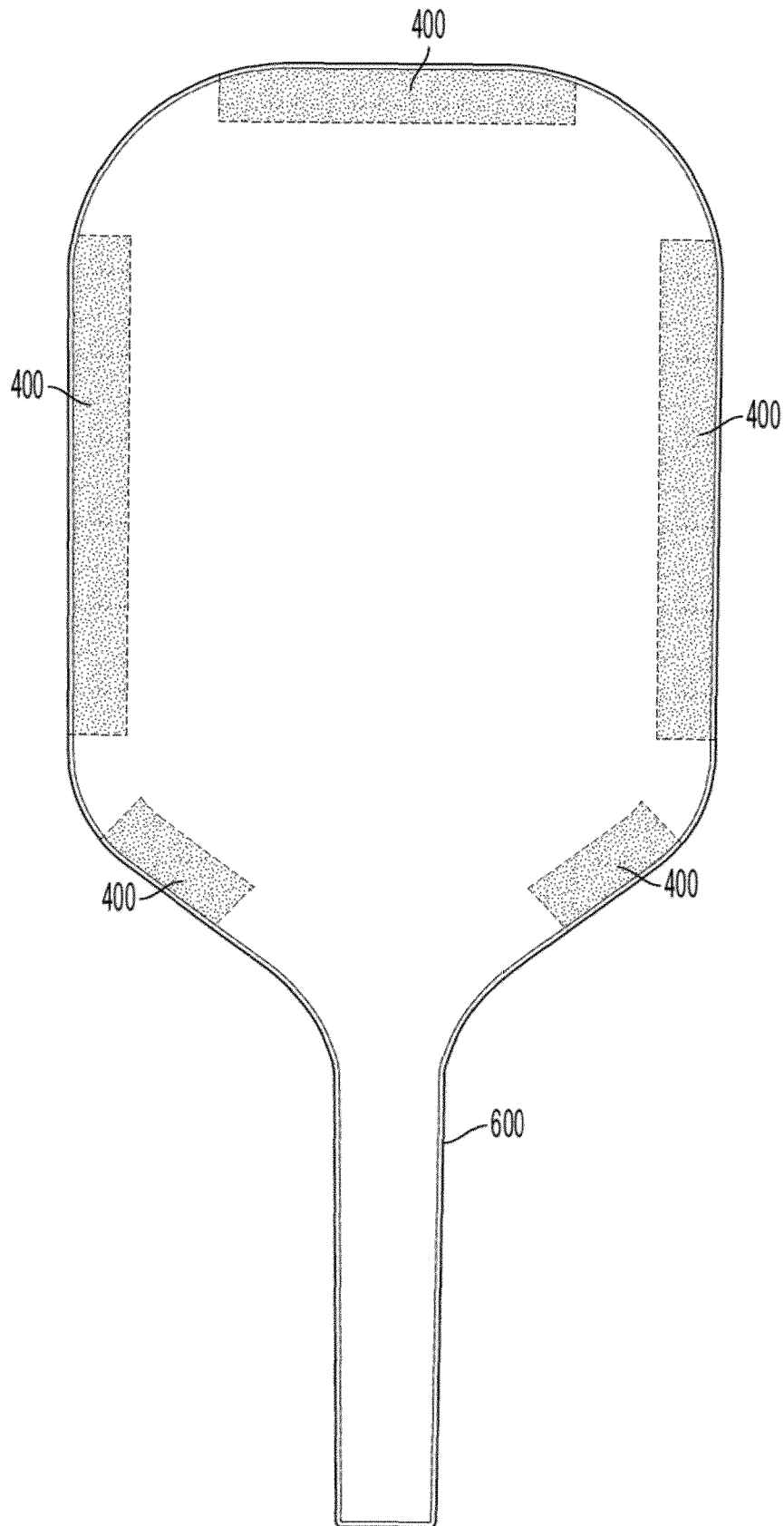

FIG. 13

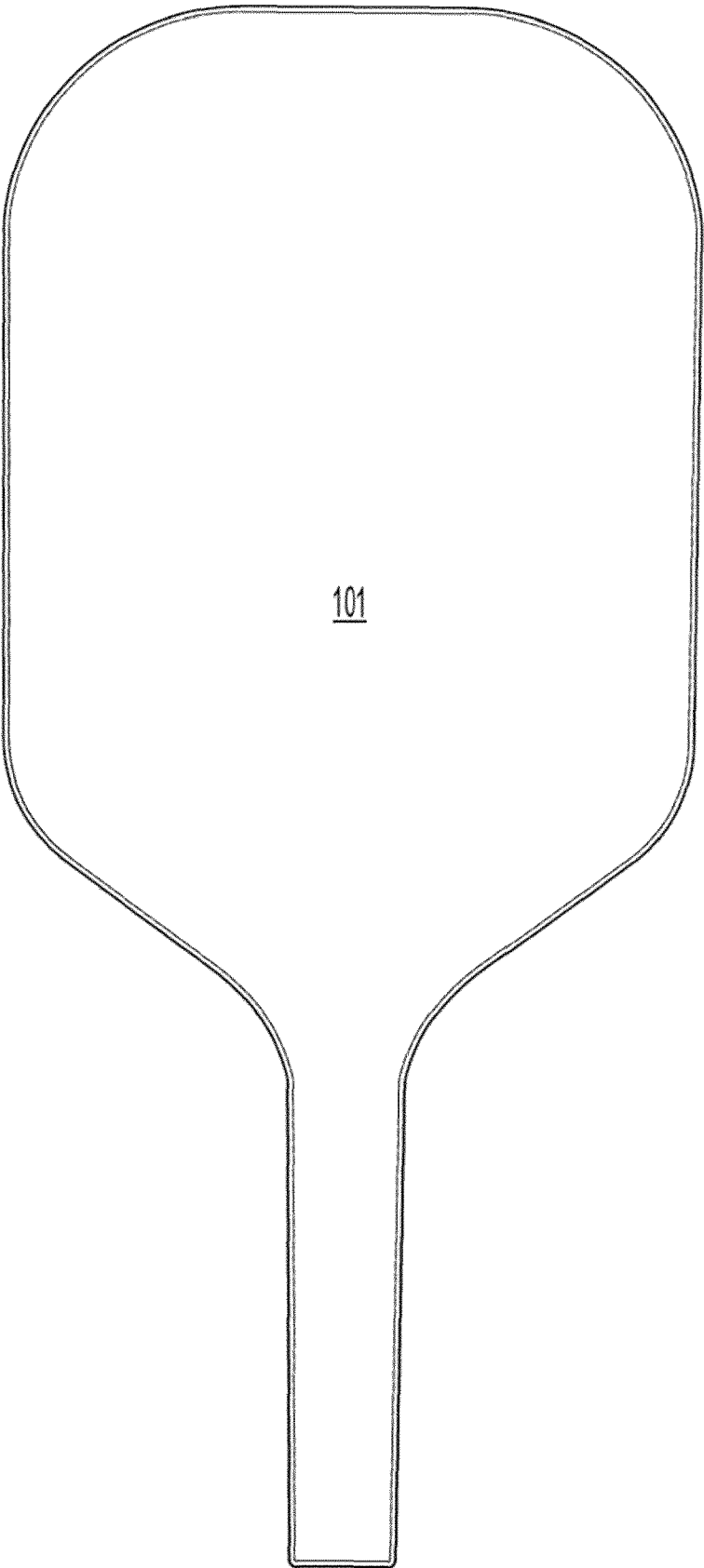

FIG. 14

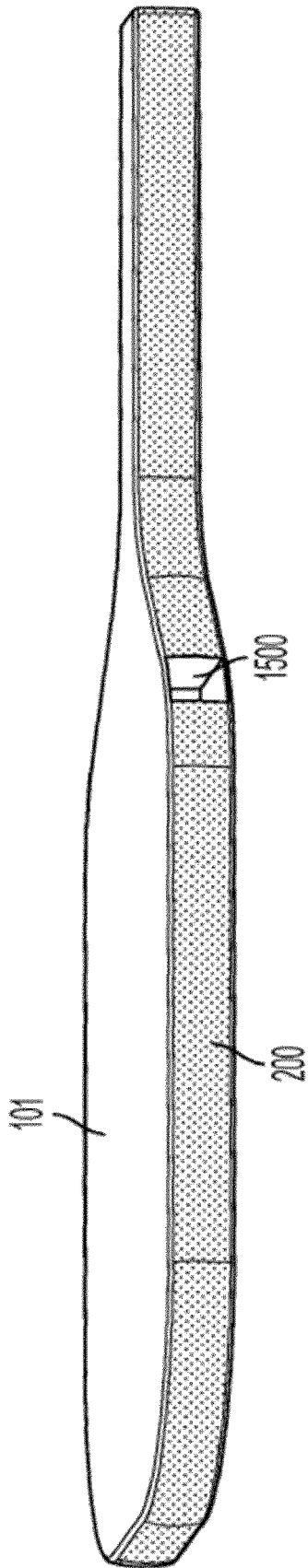

FIG. 15

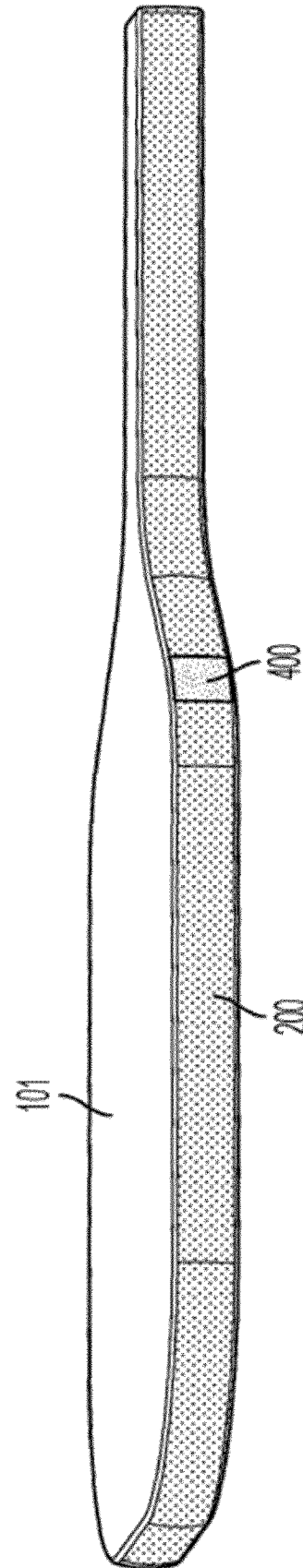

FIG. 16

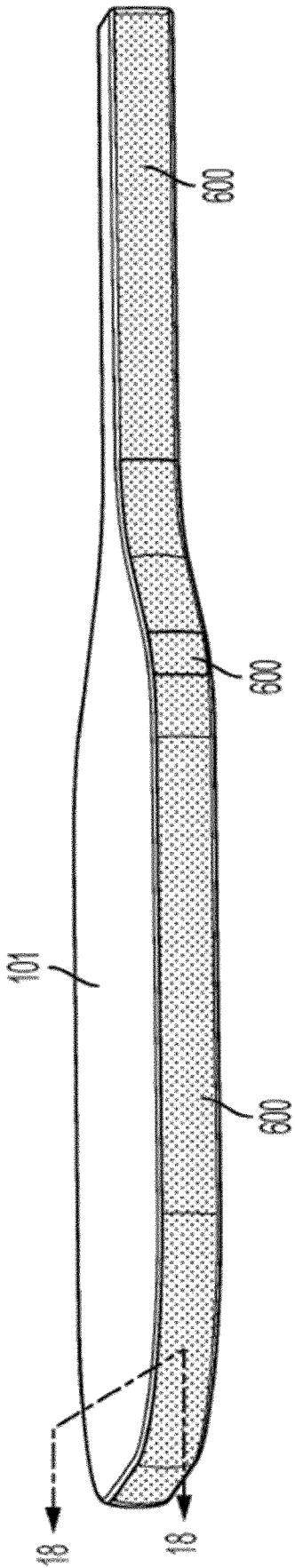

FIG. 17

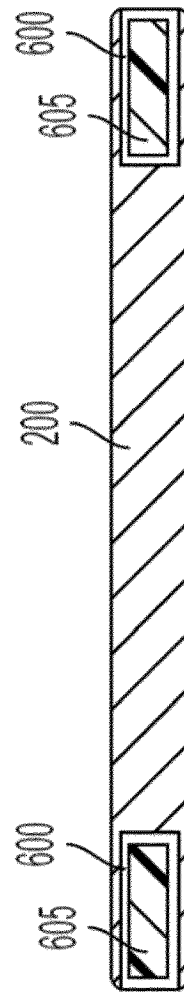

FIG. 18

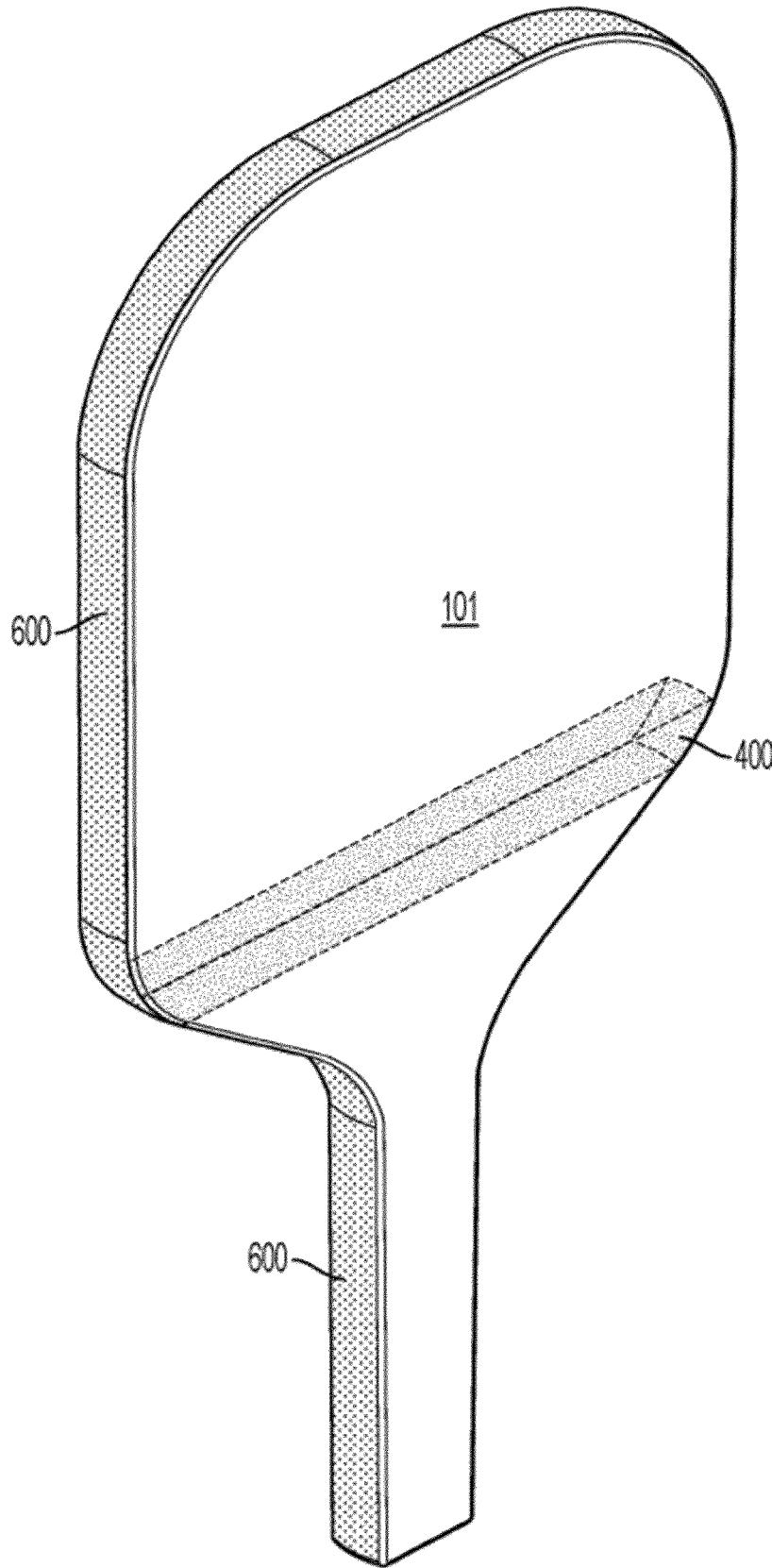

FIG. 19

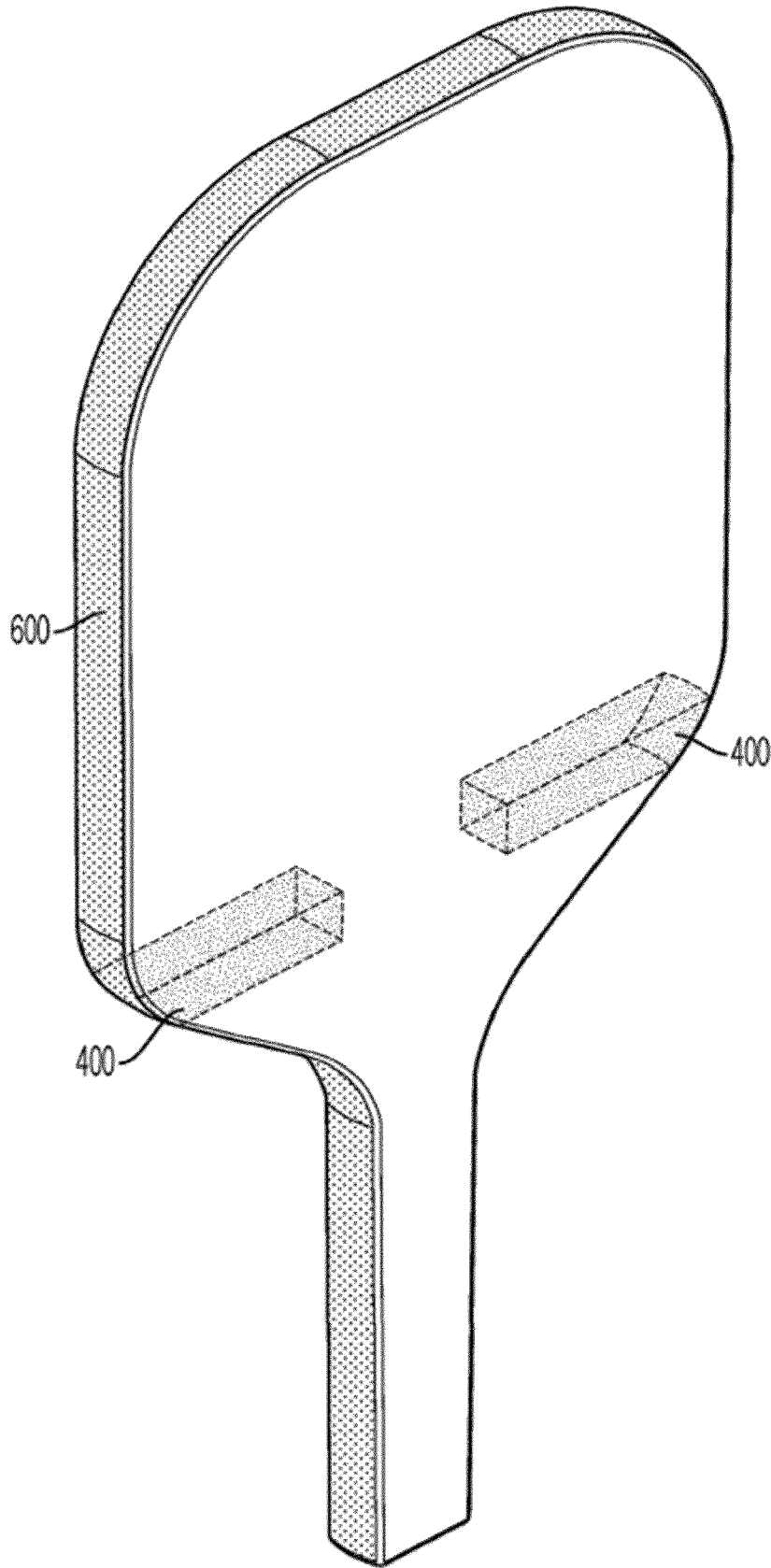

FIG. 20

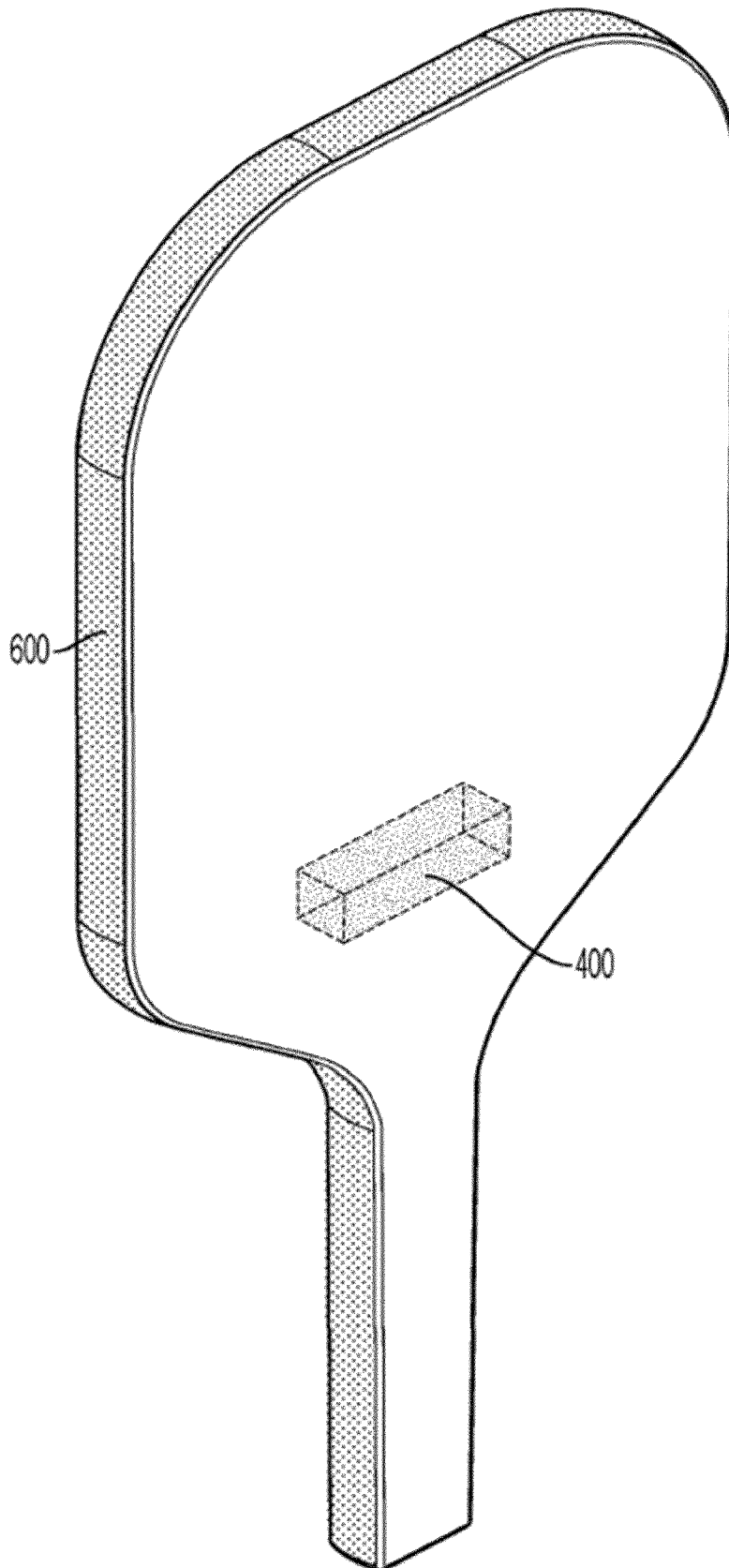

FIG. 21

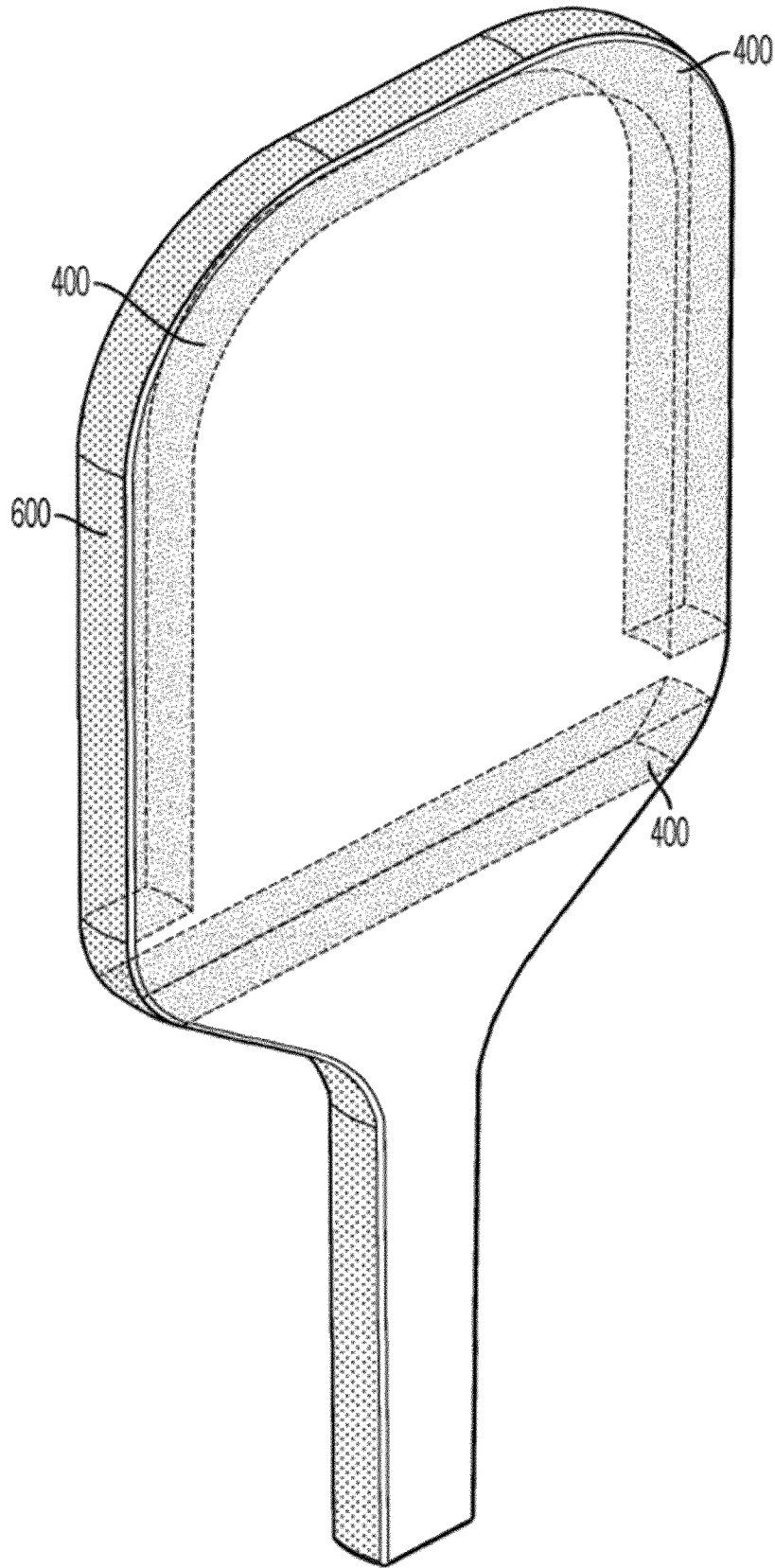

FIG. 22

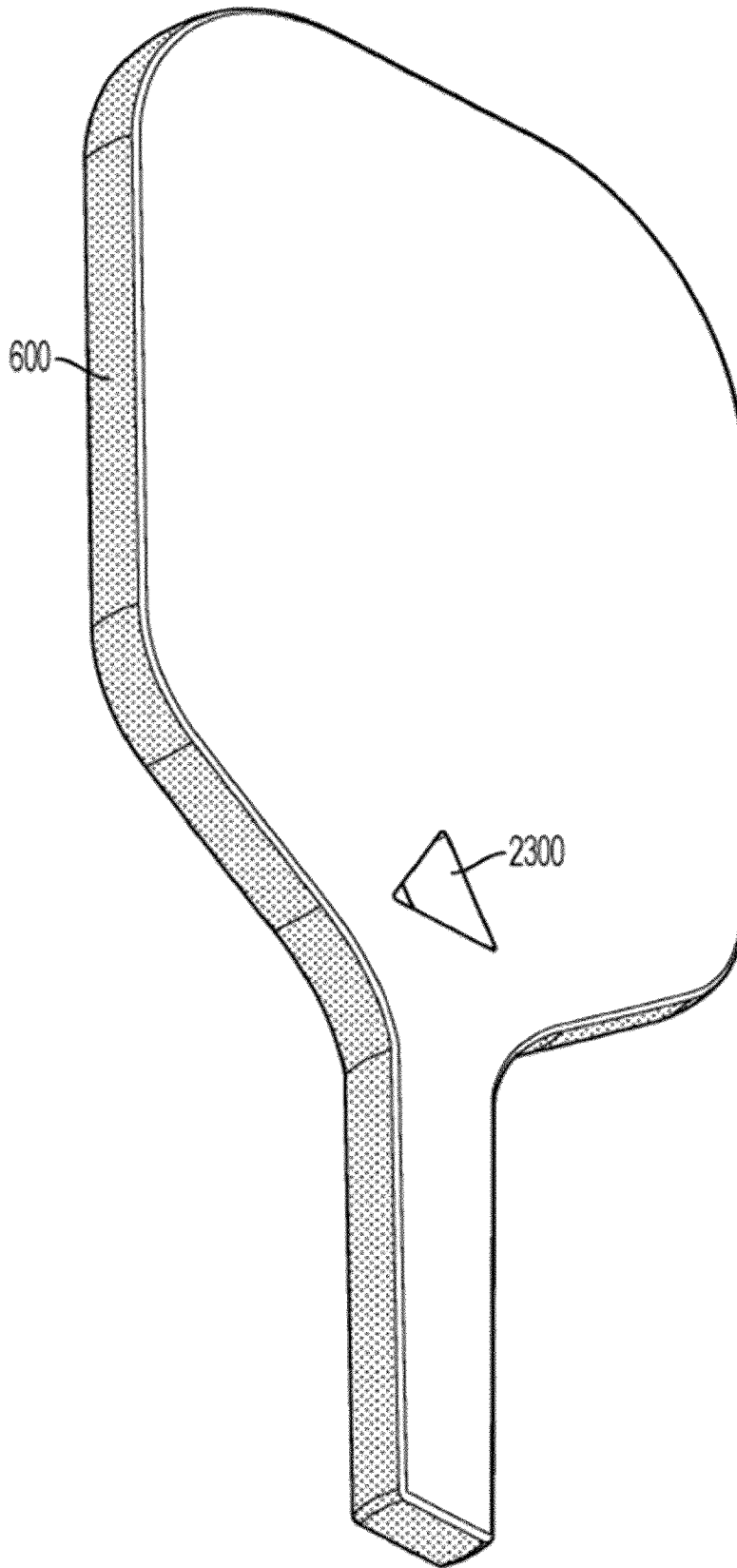

FIG. 23

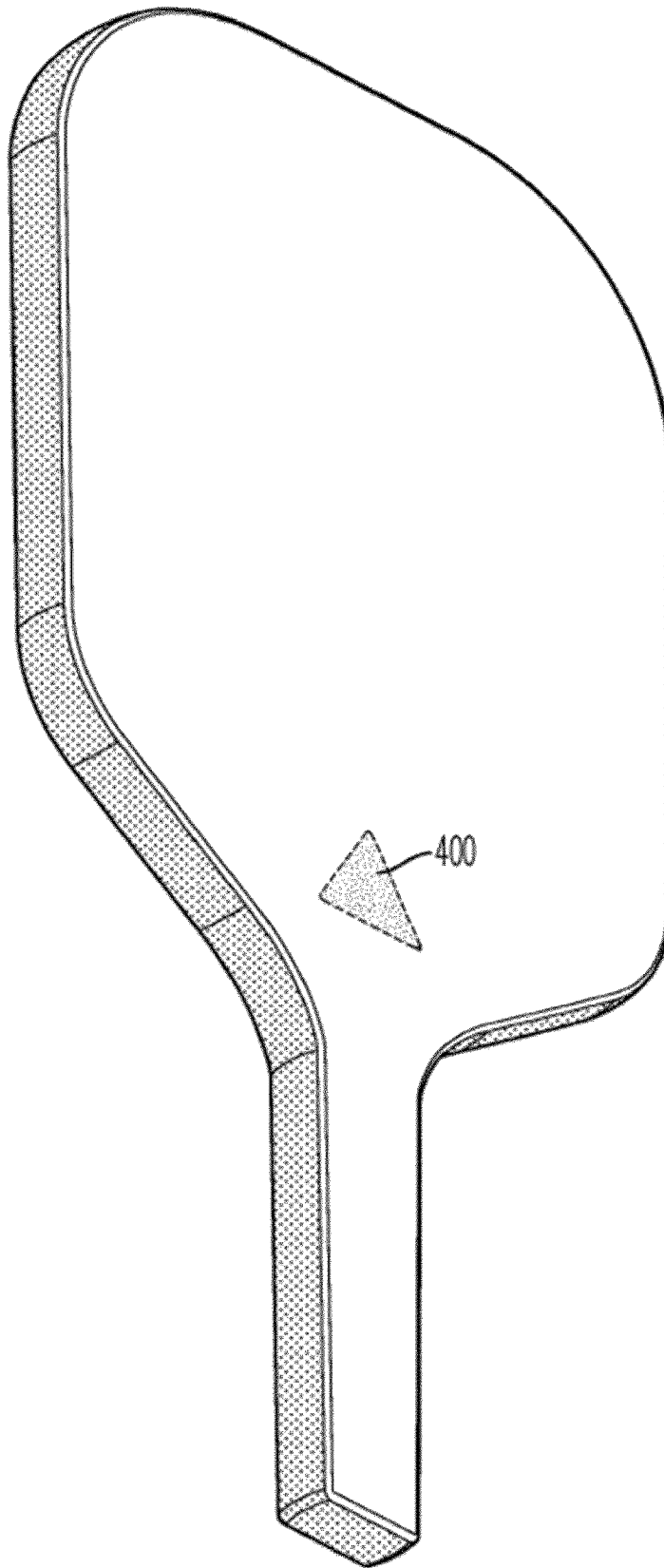

FIG. 24



FIG. 25



FIG. 26

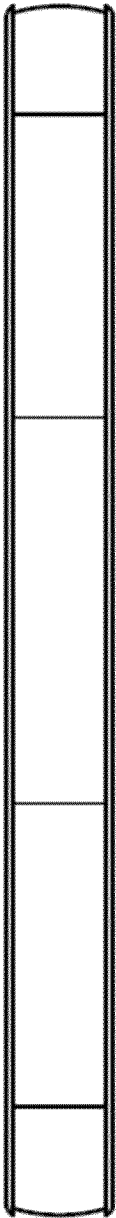

FIG. 27

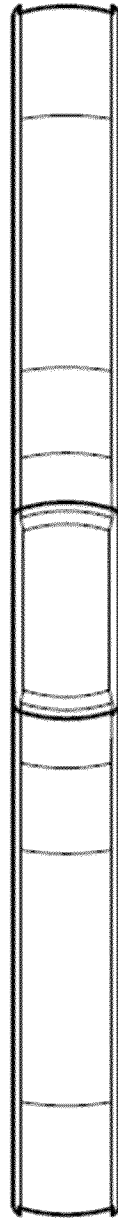

FIG. 28

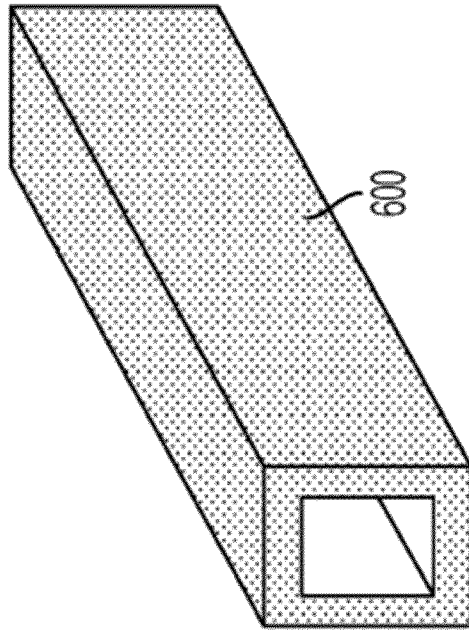

FIG. 29

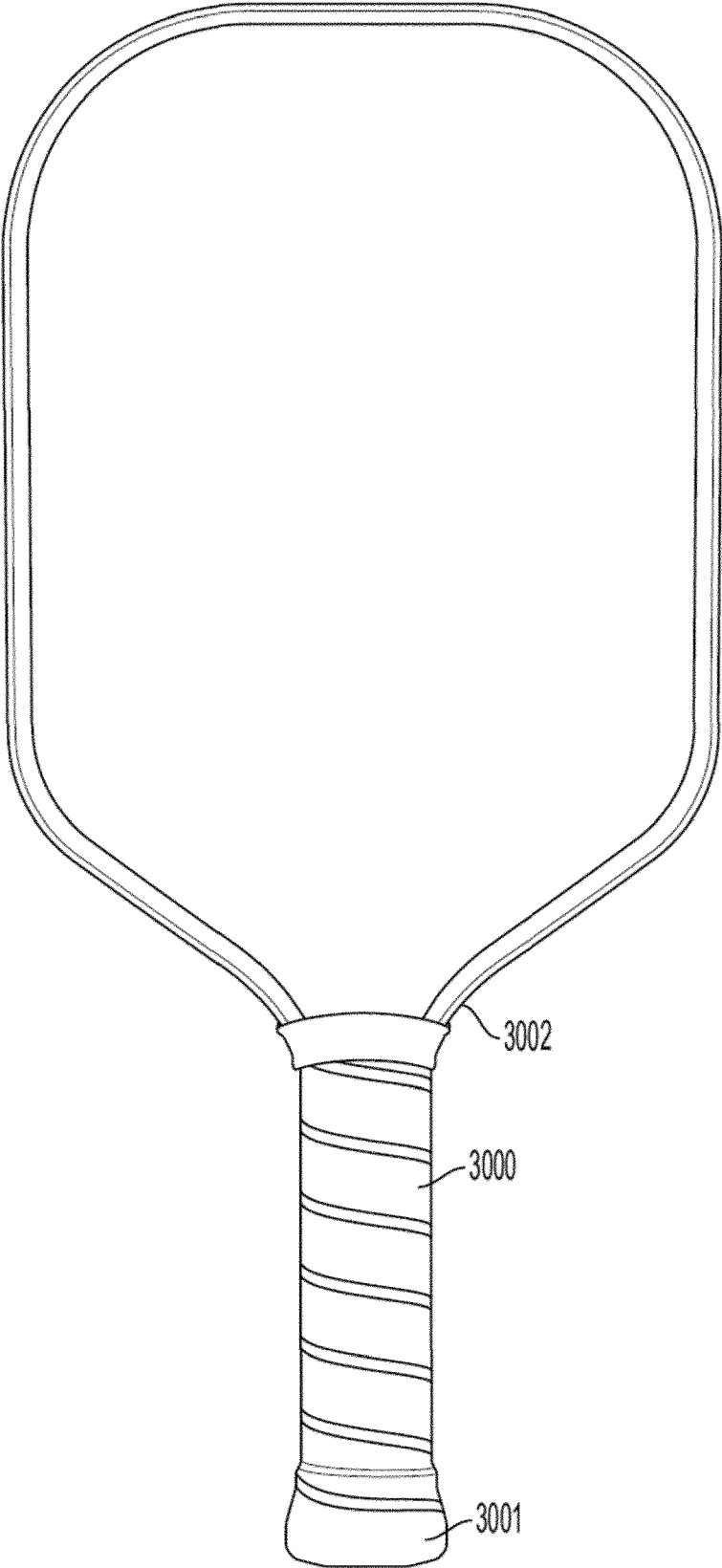

FIG. 30

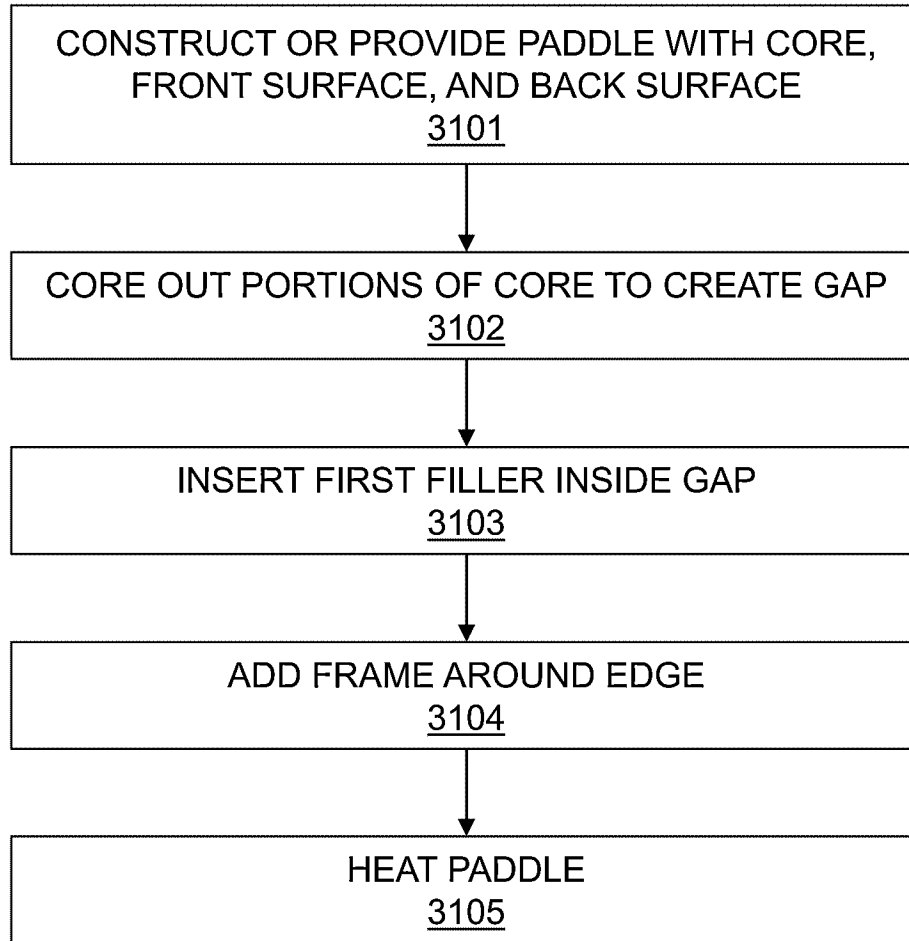

FIG. 31

US 12,465,826 B2

1

GAME PADDLE**CROSS-REFERENCE TO RELATED APPLICATIONS**

This application is a continuation of U.S. patent application Ser. No. 18/389,174 filed on Nov. 13, 2023, which claims benefit to U.S. provisional application No. 63/535,565 filed on Aug. 30, 2023, and U.S. provisional application No. 63/543,865 filed on Oct. 12, 2023, where each of the foregoing is incorporated by reference herein in its entirety.

FIELD OF THE INVENTION

The present general inventive concept is directed to a paddle and a method for manufacturing the paddle.

DESCRIPTION OF RELATED ART

Paddles for paddle sports have been used for ages. A paddle typically refers to a paddle that is not comprised of strings (such as a tennis racket). Paddles are used to play games such as pickleball, paddleball, etc.

What is needed is paddles that can provide better performance for players.

SUMMARY OF THE INVENTION

It is an aspect of the present invention to provide an improved solid game paddle and method for its manufacture.

These together with other aspects and advantages which will be subsequently apparent, reside in the details of construction and operation as more fully hereinafter described and claimed, reference being had to the accompanying drawings forming a part hereof, wherein like numerals refer to like parts throughout.

BRIEF DESCRIPTION OF THE DRAWINGS

Further features and advantages of the present invention, as well as the structure and operation of various embodiments of the present invention, will become apparent and more readily appreciated from the following description of the preferred embodiments, taken in conjunction with the accompanying drawings of which:

FIG. 1A is a drawing showing a front view of a paddle, according to an embodiment;

FIG. 1B is a drawing showing a top perspective view of the paddle, according to an embodiment;

FIG. 1C is a drawing showing a back perspective view of the paddle, according to an embodiment;

FIG. 2 is a diagonal view showing the paddle after it is cored out, according to an embodiment;

FIG. 3 is a cross section of FIG. 2, according to an embodiment;

FIG. 4 is a diagonal view of the paddle with foam added, according to an embodiment;

FIG. 5 is a cross section of FIG. 4, according to an embodiment;

FIG. 6A is a diagonal view of the paddle with a frame added, according to an embodiment;

FIG. 6B is a cross section of FIG. 6A, according to an embodiment;

FIG. 7A shows a front view of the final paddle, according to an embodiment;

2

FIG. 7B shows a back view of the final paddle, according to an embodiment;

FIG. 7C shows a side view of the final paddle, according to an embodiment;

5 FIG. 7D shows a cross section shown in FIG. 7C, according to an embodiment;

FIG. 7E shows a front view of the final paddle, according to an embodiment;

10 FIG. 7F shows a cross section from the view shown in FIG. 7E, according to an embodiment;

FIG. 7G shows a cross section from the view shown in FIG. 7E, according to an embodiment;

15 FIG. 7H shows a detailed view of the view shown in FIG. 7F, according to an embodiment;

FIG. 7I shows a detailed view of the view shown in FIG. 7G, according to an embodiment;

FIGS. 8-13 are each drawings showing a front view of a paddle, according to various embodiments;

20 FIG. 14 is a front view showing another original paddle before it is cored out, according to an embodiment;

FIG. 15 is a perspective view showing a gap, according to an embodiment;

25 FIG. 16 is a perspective view showing first filler filling in the gap, according to an embodiment;

FIG. 17 is a perspective view showing a frame added to the edge of the paddle, according to an embodiment;

FIG. 18 is a cross section of FIG. 17 showing the core, first filler, and frame, according to an embodiment;

30 FIG. 19 is a perspective view showing a front of a paddle showing first filler on the inside, according to an embodiment;

FIG. 20 is a perspective view showing a front of a different paddle showing first filler on the inside, according to an embodiment;

35 FIG. 21 is a perspective view showing a front of another different paddle showing first filler on the inside, according to an embodiment;

40 FIG. 22 is a perspective view showing a front of another alternative paddle showing first filler on the inside, according to an embodiment;

FIG. 23 is a perspective view of a paddle with filler in the throat, according to an embodiment;

45 FIG. 24 is a perspective view of the final paddle, according to an embodiment;

FIG. 25 is a left side view of a final paddle, according to an embodiment;

FIG. 26 is a right side view of the final paddle, according to an embodiment;

50 FIG. 27 is a top view of the final paddle, according to an embodiment;

FIG. 28 is a bottom view of the final paddle, according to an embodiment;

55 FIG. 29 is a drawing showing a perspective view of the frame, according to an embodiment;

FIG. 30 is a drawing of a final paddle, according to an embodiment; and

FIG. 31 is a flowchart illustrating a method used to construct a paddle, according to an embodiment.

DESCRIPTION OF THE PREFERRED EMBODIMENTS

Reference will now be made in detail to the presently preferred embodiments of the invention, examples of which are illustrated in the accompanying drawings, wherein like reference numerals refer to like elements throughout.

US 12,465,826 B2

3

A paddle can be used to play games like pickleball, racquetball, paddleball, etc. The paddle is solid, meaning that it is not made of string with holes between the string (such as a tennis racket). The paddle can have some foam (or other filler) on the inside alongside other material(s) such as core, the filler can serve to increase power, soften feel and reduce vibration.

In an embodiment, the paddle can be made with a manufacturing process. The process can begin with using an original paddle. The paddle has a front and back surface and a core on the inside, in a "sandwich structure." The front and back surfaces can be made from any material, such as one, two three, four or more layers of unidirectional or weave of carbon, glass, or any natural or synthetic fiber and prepreg impregnated with any kind of resin. The core can be comprised of any open-cell structure or lattice (e.g., honeycomb) of polypropylene, aluminum, NOMEX, KEVLAR ARAMID, or any other synthetic or natural material.

The process then will core out (remove) a portion of the core. The portion of the core that is removed (gap) depends on the embodiment, as in different embodiments, different portions of the core can be cored out. The gap can be from 0.1 to 100 mm deep (from the edge to the center of the paddle). The process will then use a first filler (e.g., foam) to fill in the cored out portion (gap) of the core. In an embodiment, instead of the first filler the cored out portion (gap) can be left hollow.

The process will then insert a first filler (e.g., foam) into the gap. Note that the first filler can be a single material or a combination of at least two different materials. The process will then wrap a frame (such as a carbon frame) around the perimeter of the entire paddle. In an embodiment, the frame can be an airtight hollow cuboid structure and has a second filler (e.g., foam) inside the frame. Note that in an embodiment, the frame may not be airtight. The second filler can be made from a single material or a combination of at least two different materials. In alternate embodiment, the frame can simply be a solid material wrapped around the perimeter. The second filler can be the same material(s) as the first filler or it can be a different material(s). In an embodiment, the frame can also be hollow. Note that a frame aspect ratio is defined as the height of the frame divided by the width of the frame, and in an embodiment, the frame aspect ratio would be lower than a predefined number (e.g., 4).

FIG. 1A is a drawing showing a front view of an original paddle **100**, according to an embodiment. The front view and back view are identical. FIG. 1B is a drawing showing a top perspective view of the paddle, according to an embodiment. FIG. 1C is a drawing showing a back perspective view of the paddle, according to an embodiment. The paddle **100** is utilized to create the improved paddle as described herein. Note that any paddles described herein are not limited to any particular shape and any shape and/or thickness can be used. The front surface **101** and the back surface **102** can be made from any material, such as 1-4 or more layers of unidirectional or weave of carbon, glass, or any natural or synthetic fiber and prepreg, impregnated with any kind of resin are commonly used for the composite materials. Typically, the front surface **101** and the back surface **102** are made from the same material, although this is not required. A handle **105** is on the bottom of the paddle **100** and a head **110** is above the handle **105**. Example dimensions (in inches) for such a paddle can be, 15-17" (length)×9-7" (width), or 16.5"×7.5" or 16"×8". Grip length: 4-6", or 4.75-5.75". Grip circumference: 4-4.5", or 4-4.3", although these are just examples and any other dimensions can be used.

4

Note that the handle **105** can be defined as the bottom of the racket up unto the point where the curvature of the perimeter of the paddle (without a grip) starts to change (e.g., a straight line starts to curve). This point is shown in FIG. 1A by the dotted line 'H'. The face of the paddle can be considered the rest of the paddle, that is from the handle to the top of the paddle. The face can be broken up into two sections, the head **110** and the throat **103**. The head **110** is from the top of the paddle down to where the perimeter starts to curve (from a straight edge) which is shown in FIG. 1A by the dotted line T. The throat **103** is the region between the head and the handle. Thus, the face of the paddle comprises only the head **110** and the throat **103** but not the handle **105**. The height of the face is shown by the dotted line 'F' in FIG. 1A. All sections (e.g., head, throat, handle) are delineated by horizontal lines. These sections can be considered to extend throughout the thickness of the paddle.

An alternative method of determining the head and the throat sections is as follows. The height of the face is determined by measuring the distance from the top of the paddle to where the handle begins (which can be determined based on when the curvature becomes straight, or by the user of a different material for the handle, etc.) The bottom one third of this height (e.g., the bottom $\frac{1}{3}$ of the face) is the throat, and the top two thirds of this height (e.g., the top $\frac{2}{3}$ of the face) is the head. As an example of this method, assume the height of the face (shown as vertical line F) in FIG. 1A is 10 inches (from the top of the paddle to the top of the handle). The 10 inches does not include the handle. Then the throat cutoff line (shown as horizontal line T) is just at the lower $\frac{1}{3}$ of the face height, that is 3.33 inches over the top of the handle is the throat (or 6.66 inches below the top of the paddle). The region below the throat cutoff line and above the handle is the throat region. While FIG. 1A is drawn as 2-dimensional, the regions described herein extend into the thickness of the paddle.

FIG. 2 is a diagonal view showing the paddle after it is cored out, according to an embodiment. A core **200** is present between the front surface **101** and the back surface **102**. The core **200** can be comprised of any open-cell structure (or a plastic sheet closing the cells), lattice (e.g., honeycomb), or any other such structure, comprised of polypropylene, aluminum, NOMEX, KEVLAR or any other synthetic or natural material. "Coring out" comprises removing sections of the core **200** from the paddle **100**. This can be done by using a drill or other tool which creates a gap **202** where the core **200** previously existed. See operation **3102** and its accompanying description for more information on the coring out operation.

FIG. 3 is a cross section of FIG. 2, according to an embodiment. Between the top surface **101** and bottom surface **102** is the gap **202**. The gap **202** can be from 0.1 to 100 mm depth (from the edge to the center of the paddle), it can be continuous around all the paddle, or split in two, three, four or more sections of different lengths, depths, and shapes. The height of the gap can vary from 0.1 to 25 mm or to the max thickness of the core. The gap can be of any shape, concave, convex, U shape, or others.

FIG. 4 is a diagonal view of the paddle with foam added, according to an embodiment. A first filler **400** is added in the gap **202** although it does not completely fill the gap **202** as room is left for a frame (e.g., carbon frame). The first filler **400** can be EVA foam, polymer, thermoplastic, thermoset, thermoplastic elastomer, elastomer, rubber, foam, expandable material, or a mixture of any combination of these. The first filler **400** can be of any density, viscosity, and hardness.

US 12,465,826 B2

5

See operation **3103** and its accompanying description for more information on how the filler is applied.

The first filler **400** (and the gap **202** which it fills) can be of any cross-section shape, the height can vary from 0.1 to 25 mm or to the max thickness of the core, the width (distance from the frame wall to the core) can vary from 0.1 to 50 mm. The first filler **400** can be continuous around all the core or can be split in two, three, or more sections with same or different geometries, dimensions, and materials. The first filler **400** can surround the entire paddle, just the head, or just specific areas.

FIG. **5** is a cross section of FIG. **4**, according to an embodiment. Shown inside the gap **202** is the first filler **400**.

FIG. **6A** is a diagonal view of the paddle with a frame added (such as a carbon frame), according to an embodiment. A frame **600** is added around the edge of the paddle **100**. The frame **600** can be comprised of carbon, glass, or any synthetic or natural fiber with resin, plastic, rubber, metal, or any material that provides a rigid structure. The frame **600** can be of any cross-section shape, height, width, and length. It can be an entire piece or can be split into two, three, or more sections with same or different geometries and dimensions. The frame **600** can surround the entire paddle, just the head, just the handle, or just specific areas. See operation **3104** and its accompanying description for more information on how the frame is applied. An edge guard (not pictured) can be optionally used or not to cover the frame and a small area of the surfaces on both sides.

FIG. **6B** is a cross section of FIG. **6A**, according to an embodiment. The frame **600** is a hollow cuboid (or other) structure which houses a second filler **605**. The second filler **605** can be polymer, thermoplastic, thermoset, thermoplastic elastomer, elastomer, rubber, foam, expandable material, or a mixture of any combination of these. The second filler **605** can be of any density, viscosity, and hardness, and can be a single material or combination of different materials. The second filler **605** can be the same material as the first filler **400** or it can be a different material. In an embodiment, the second filler **605** can also be pressurized air (high pressure) since the frame **600** can be airtight or it can be hollow. Also shown is the core **200**. When the frame is a shell structure as shown, the frame wall can range from 0.01-10 mm, 0.1-10 mm, or 0.1-4 mm, or other ranges. Frame height: 1-20 mm or to the max thickness of the paddle. Frame width can be 1-30 mm, or 5-15 mm. The frame can also be a solid structure (not shell structure), in this case the examples of dimensions would be the same, but there's no wall thickness in this case.

FIG. **7A** shows a front view of the paddle with the frame installed, according to an embodiment. FIG. **7B** shows a back view of the paddle with the frame installed, according to an embodiment. The paddle shown in FIGS. **7A** and **7B** is the final paddle after the manufacturing process is complete. The first filler **400** and the second filler **605** are not visible to the user because they are internal to the paddle. However, the first filler **400** and the second filler **605** are inside the paddle and hence the user cannot see them and may not even know the first filler **400** and the second filler **605** are present inside the paddle. With any of the embodiments described herein, the final paddle will appear like FIGS. **7A** and FIG. **7B** because the internal structure (e.g., core, first filler, second filler, etc.) would not be visible.

FIG. **7C** shows a side view of the final paddle, according to an embodiment. FIG. **7D** shows a cross section shown in FIG. **7C**, according to an embodiment. Shown is the frame **600** with the second filler **605** inside the frame **600**. The first

6

filler **400** is present inside the core **200** which fills the gap **202** previously made in the core **200**.

FIG. **7E** shows a front view of the final paddle, according to an embodiment. The back view of the final paddle is identical to the front view. Note that the frame surrounds the entire final paddle. In an embodiment, the frame does not surround the entire paddle but only a portion of it, for example, the frame can only surround a part of the head of the paddle, or just part of the handle, etc., FIG. **7F** shows a cross section from the view shown in FIG. **7E**, according to an embodiment. FIG. **7G** shows a cross section from the view shown in FIG. **7E**, according to an embodiment. Note that in FIG. **7G** there is no first filler **400** (as shown in FIG. **7F**) because the portion of the paddle shown in FIG. **7G** was not cored out and hence no first filler **400** was applied to that region. FIG. **7H** shows a detailed view of the view shown in FIG. **7F**, according to an embodiment. Note that FIG. **7H** shows a height and width measurement of the frame. The frame aspect ratio is the height/width. In one embodiment, the frame aspect ratio should be smaller than 4 (or smaller than equal to 4). In another embodiment, the frame aspect ratio should be smaller than 6, or smaller than 4, or smaller than 2, or other numbers. FIG. **7I** shows a detailed view of the view shown in FIG. **7G**, according to an embodiment.

FIGS. **8-13** are each drawings showing a front view of a paddle, according to various embodiments. Note that the back view of each paddle would be identical to the respective front view. All other structures not shown would be the same as described herein. In each of these figures, the first filler is shown which is inside the respective paddle and would not be visible to the user. Before the first filler is added, as described herein, the section where the first filler is shown was cored out (the gap). All of these embodiments also have the frame (with the second filler inside the frame) applied around the entire edge as described herein. Thus, all of the embodiments shown in FIG. **8-13** can be constructed using the process described herein, and can have the same general structure as shown in FIGS. **2-7I** but for the different location and shape of the gap which was cored out of the original paddle and filled with the first filler. Note that other configurations of core and first filler can be used as well, and these are just examples. Note that in FIGS. **8-13**, the first filler and the second filler are both not visible to the user as they are both embedded inside the paddle (the first filler being inside the game and the second filler being inside the frame). The paddles shown in FIGS. **8-13** would appear as shown in FIGS. **7A**, **7B** because any internal structures (first filler **400**, second filler second filler **605**, core **200**, etc.) would not be visible as it would be covered by the front and back surfaces and possibly the frame **600**.

In the embodiment shown in FIGS. **7D** and **8-13**, the gap and filler used to fill the gap were near the perimeter of the head (the head being opposite of the handle) of the paddle. In a further embodiment, the gap and filler used to fill the gap can be in other locations in the paddle (not just near the perimeter), although typically closer to the handle than the head. FIGS. **14-18** illustrate the method of constructing a paddle where the gap and filler used to fill the gap are present in various locations inside the paddle. Note that the construction process can be the same as shown with respect to FIGS. **1-13**.

FIG. **14** is a front view showing another original paddle before it is cored out, according to an embodiment. FIGS. **15-19** show a process of how a dampener is applied to this original paddle. Note that the core is present throughout the another original paddle (as shown in other figures) and is surrounded by a front and back surface. The outer surfaces

US 12,465,826 B2

7

can be comprised of one, two, three, four or more layers of unidirectional or weave of carbon, glass, or any natural or synthetic fiber and prepreg, impregnated with any kind of resin. The core 200 can be comprised of a honeycomb structure of polypropylene, aluminum, Nomex, Kevlar or any other synthetic or natural material. The core is not limited to a honeycomb structure. The core can form the entire paddle (head and handle) or the head only. The core can be surrounded by an edge guard, or any type of frame, or edgeless.

FIG. 15 is a perspective view showing the paddle from FIG. 14 after it was cored out, according to an embodiment. Note that a gap 1500 in the core 1400 is where the core 1400 was drilled (or other process) to form the gap 1500. Note that the gap 1500 is near the handle 1501. FIG. 16 is a perspective view showing a first filler filling in the gap (as described herein), according to an embodiment. The gap 1500 (and hence the first filler) extends throughout the entire original paddle. Note that the gap 1500 extends throughout the paddle and out through the opposite side of the paddle. While the gap 1500 extends throughout the paddle, the paddle does not collapse into two sections because the front and back surface keep the paddle together until the first filler is inserted to fill the gap 1500. Because the gap is typically smaller than the total thickness of the paddle, leaving some part of the original core, which also helps the paddle to not collapse. FIG. 19 shows the first filler 1600 extending throughout the original paddle.

The gap 1500 is used to place the vibration dampener (first filler) but can also be hollow partially or completely. The gap can be of any dimension, cross section shape and any position, it can be continuous across all the paddle, or split into two, three, four or more sections of different lengths, widths, and shapes. It can be linear or curved, in the center of the paddle or in the edges. The gap can be inside the sandwich structure or also reach/pass the front and back surfaces. It can be on the head (edges, center, top, bottom), neck, or handle of the paddle. Multiple gaps can be used simultaneously in the same or different parts of the paddle. If the gap is located in the edges of the paddle, it can be exposed to the outside (on both edges of the paddle), or can be covered with a frame, edge guard or any other material or structure.

The gap 1500 is then filled with a first filler 1600. The first filler can be a foam, polymeric foam, solid, liquid, gel of any type of polymer, thermoplastic, thermoset, thermoplastic elastomer, elastomer, rubber, expandable material, and any other material or a mixture of them. The first filler can feel completely or partially the gap 1500. The first filler can be directly touching the core structure, or can be covered/encapsulated by other material, for example a thermoplastic film or carbon fiber, not limited to these materials. If the gap 1500 reaches the surface, the first filler 1600 can be exposed on the surface or can be covered with glass fiber, carbon fiber, adhesive or any other material.

FIG. 17 is a perspective view showing a frame added to the edge of the paddle from FIG. 16, according to an embodiment. After the gap 1500 is filled with the first filler 1600, a frame 1700 can be added to the edge (perimeter) as described herein. Note that in some embodiments, where there is no gap on the edge of the paddle, adding the frame may not be necessary. The frame 1700 can have a second filler as described herein. Note that the final paddle will appear as shown in FIGS. 7A and 7B.

FIG. 18 is a cross section of FIG. 17 showing the core, foam, and carbon frame, according to an embodiment. The frame 1700 contains a second filler 1800. FIG. 19 is a

8

perspective view showing a front of a completed paddle (FIG. 17) showing the first filler on the inside, according to an embodiment. The first filler 1600 is inside the gap 1500 cut inside the core 1400. The first filler 1600 is not visible to the user as it is entirely inside the paddle.

FIGS. 19-22 are each drawings showing a diagonal front view of a paddle, according to various embodiments. Note that the back view of each paddle would be identical to the respective front view. All other structures not shown would be the same as described herein. The paddles shown in FIGS. 19-22 can be constructed as described herein.

FIG. 19 is an example of a paddle showing the horizontal gap (and first filler) across the entire paddle, and was shown being constructed in FIGS. 15-18. FIG. 20 is an example of a paddle showing the horizontal gap (and first filler) just in the sides of the paddle. FIG. 21 is an example of a paddle showing the horizontal gap (and first filler) just in the center of the paddle. The gap (and first filler) is not limited to these examples or to horizontal gaps, and other shapes, dimensions, and configurations can be used as well. Note in FIGS. 19-21 (as in FIGS. 7D and 8-13), the first filler is completely inside the paddle and is not visible to the user. The second filler is also completely inside the paddle (inside the frame) and is also not visible to the user.

Note that when the gap and first filler is entirely in-between the head and the handle (the throat), it can be referred to as a dampener (such as shown in FIGS. 19-21). In other words, a dampener does not have any portion of filler outside of the throat of the paddle (e.g., above the throat line or below the top of the handle). Note that when the gap and the first filler is near the perimeter/edges of the paddle (such as shown in FIGS. 7D and 8-13) then it can affect properties of the paddle, which can for example increase spin and boost of the ball. This can be because the first filler (e.g., foam) inside the paddle, in one embodiment, can slightly vibrate when the paddle strikes a ball, which enhances the feel of the player when striking the ball. A dampener can reduce vibration on the handle. Note that in an embodiment, a dampener can be considered a piece of foam that is entirely inside the throat of the paddle. Note that in an embodiment, using the frame as described herein can be optional. In one embodiment, if a paddle contains a dampener, then there would not be a frame used.

Note that the ratio of volume of first filler to volume of the core can be relatively large (meaning there is a relatively large amount of first filler used in the paddle). For example, in a particular paddle, a ratio $r = \text{volume of all first filler} / \text{volume of all core}$. In an embodiment, the ratio r can be 5%. In another embodiment, r can be from 5% to 75%. In another embodiment, r can be from 25% to 50%. In another embodiment, r can be from 10% to 20%. In an embodiment, an acceptable range of r would be from 1% to 30%.

Note that both a dampener (gap with filler between the head and the handle) and gap with filler near the edge can also be combined into the same paddle, see FIGS. 8, 9, 22. FIG. 22 is a perspective view showing a front of another alternative paddle showing first filler both around the perimeter as well is throughout a section between the head and the handle, according to an embodiment.

FIG. 23 is a perspective view of a paddle with a gap cut through the front and back surfaces, according to an embodiment. Note in this embodiment, a gap 2300 is cut throughout the core, front and back surface of the paddle.

FIG. 24 is a perspective view of the paddle with the gap cut through the front and back surfaces with filler, according to an embodiment. A first filler 2400 is inserted into the gap 2300. The front surface and back surface can then be coated

US 12,465,826 B2

9

with an external coating (but alternatively could be visible without any coating/cover), such as a carbon fiber layer, to cover the entire front and back surface including the first filler **2400**. As such, the first filler **2400** would not be visible to a user after the external coating is applied. FIGS. **17**, **19-22** and **24** would all appear visually as FIGS. **7A**, **7B** since all of the internal structures (e.g., core **200**, first filler **400**, second filler **605**, etc.) would be covered by the front and back surfaces and possible the frame **600**.

FIG. **25** is a left side view of a completed paddle, according to an embodiment. FIG. **26** is a right side view of the completed paddle, according to an embodiment. FIG. **27** is a top view of the completed paddle, according to an embodiment. FIG. **28** is a bottom view of the completed paddle, according to an embodiment. Note that a completed (finished) paddle can appear on the outside as shown in FIGS. **7A** and **7B** as well as FIGS. **25-28**. Note that the surfaces shown in FIGS. **25-28** are all frame **600** although the shading does not match the shading used in the other FIGS with regard to the frame **600** in order to show the contours.

FIG. **29** is a drawing showing a perspective view of the frame, according to an embodiment. Shown is the frame which can be made out of carbon or other material. The frame (before curing/heating) is malleable so it can be bent around the perimeter of the paddle. It can be glued onto the edge of the paddle using glue or other adhesive. While shown with an open face in FIG. **29**, the face can be closed (sealed) on both ends, thereby creating an airtight frame in which pressurized air or other materials can be sealed therein.

FIG. **30** is a drawing of a completed paddle, according to an embodiment. The paddle can have an optional grip **3000**, an optional end cap **3001**, and an optional edge guard **3002**. The edge guard can be used or not to cover the frame and a small area of the surfaces on both sides. The edge guard can be made from PVC, any type of polymer, thermoplastic, thermoset, elastomer, rubber, foam, expandable material, or a mixture of any of these. Example dimensions (in inches) for such a paddle can be, 15-17" (length)×9-7" (width), or 16.5"×7.5" or 16"×8". Grip length: 4-6", or 4.75-5.75". Grip circumference: 4-4.5", or 4-4.3", although these are just examples and any other dimensions can be used. When determining the locations/dimensions of the head, throat, handle, face, etc., the edge guard, end cap, and grip are not used.

FIG. **31** is a flowchart illustrating a method used to construct a paddle, according to an embodiment. This method (and its individual operations) can be used to construct any paddle described or illustrated herein. All operations described herein can be applied to any embodiment described herein.

In operation **3101**, an original paddle can be constructed or provided. The original paddle will be constructed from core which can be comprised of any open-cell structure or lattice of polypropylene, aluminum, Nomex, Kevlar or any other synthetic or natural material. Outer surfaces (e.g., front surface and back surface) can be comprised of any material, for example one, two, three, four or more layers of unidirectional or weave of carbon, glass, or any natural or synthetic fiber and prepreg, impregnated with any kind of resin are commonly used for the outer surface. The front and back surface can be glued to the core, creating a "sandwich" of core between the front and back surfaces. See FIGS. **1A**, **1B**, **1C** for an original paddle. Note that in an embodiment, the front and back surface can be glued onto the core after the core is cored out, providing easier access to the core.

10

From operation **3101**, the method can proceed to operation **3102**, in which portions of the core are cored out (removed) to create a gap. This can be done by using a tool such as a router, running drill, press, saw, or any other mechanical tool. The coring can be performed through edges of the paddle (See FIG. **2**). In the embodiment where the intended gap does not touch the edge of the core, then the coring out of the core could be performed before assembling the sandwich structure (e.g., before attaching the front surface and back surface to the core). This method of coring out the core can also be done even if the gap does touch the edge of the core. The gap can be from 0.1 to 100 mm depth (from the edge to the center of the paddle), it can be continuous around all the paddle, or split in two, three, four or more sections of different lengths, depths, and shapes. The height of the gap can vary from 0.1 to 25 mm or to the max thickness of the core. The gap can be of any shape, concave, convex, U shape, or others. There can also be shapes created within the core while the core is attached to the edge.

From operation **3102**, the method proceeds to operation **3103**, in which a filler (first filler) is placed (inserted) into the gap. The filler can be pressurized (e.g., in a can) and sprayed in, or can be spread inside the gap using a tool (e.g., applicator gun (such as a foam dispensing gun), etc. The gap can be entirely filled in with the first filler or some gaps can still remain. In an embodiment, the first filler can be cut to the exact shape of the gap and added by hand. The first filler can be an empty space (or pressured air and the frame can be airtight), or filled with any type of polymer, thermoplastic, thermoset, thermoplastic elastomer, elastomer, rubber, foam, polymeric foam, expandable material, or a mixture of them. The first filler material can be expandable, for example if the first filler material is foam it can be expandable form. The first filler can be of any cross-section shape, the height can vary from 1 to 25 mm or to the max thickness of the core, the width (distance from the frame wall to the core) can vary from 0.1 to 50 mm. According to the gap geometries and shape, the first filler can be continuous around all the core or can be split in two, three, or more sections with same or different geometries, dimensions, and materials. The first filler can surround the entire paddle, just the head, or just specific areas.

From operation **3103**, the method can proceed to operation **3104**, which adds the frame to the edge of the paddle. The frame is a hollow cuboid structure (or other structure which does not have to be hollow) which wraps around the entire edge of the paddle. The frame can be bendable in order to mold it to the shape of the edge of the paddle. An adhesive (e.g., glue, cement, etc.) can be used to adhere the frame to the paddle. The frame (e.g., carbon frame) is bendable before the heating operation, but after the heating the resin sets and the frame becomes hard. The frame can be adhered to the paddle by the resin in the carbon fiber and because it gets hard it won't change the shape of the frame. The frame can be made of carbon, glass, fiberglass, thermoplastic, or any synthetic or natural fiber with resin, plastic, rubber, metal, or any material that provides a rigid structure. To make the carbon frame, a sheet of carbon fiber prepreg (impregnated with thermoset resin) is rolled to form a tube structure. Inside this tube there's a piece (continuous and long, about the same length of the tube) of the second filler (such as expandable foam). The frame can be of any cross-section shape, height, width, and length. It can be an entire piece or can be split in two, three, or more sections

US 12,465,826 B2

11

with same or different geometries and dimensions. The frame can surround the entire paddle, just the head, just the handle, or just specific areas.

The frame can be hollow or filled with a filler (second filler). This second filler can be of any polymer, thermo-
5 plastic, thermoset, thermoplastic elastomer, elastomer, rubber, foam, polymeric foam, expandable material, or a mixture of them. The second filler can be of any density, viscosity, and hardness. The second filler can be inserted into the frame using a number of alternate methods (in addition
10 to those described herein), such as blowing it inside, injecting it, pressuring the second filler and then shooting it inside the frame, etc. The second filler (e.g., expandable foam) can be inserted into carbon frame by hand, it is a solid piece before the hot molding process. The second filler can also be
15 air and the frame can be airtight.

From operation **3104**, the method proceeds to operation **3105**, which heats up the paddle. Once the first filler has been added to the paddle (inside gap(s) in the core) and the
20 frame has been added to surround the paddle, and the second filler is added inside the frame, and the front and back surface are attached (e.g., glued) to the core, then the paddle can be placed inside a mold. The frame can be bent around the edge (perimeter) of the paddle. The paddle can then be
25 heated in the mold which has a shape to match the paddle. The mold is closed with high pressure inside and the temperature is raised inside the mold to around 100 degrees Celsius or more for 2-20 minutes or more. With the high temperature, the second filler inside the frame expands so
30 the frame gets its shape. The first filler inside the gap(s) also can expand therein. If expandable foam (e.g., a polymer with a foamy agent) is being used for the first filler and/or the second filler, then the expandable foam can expand and harden when heated. Also, with the high temperature, the resin impregnated in the frame sets (becomes hard) so it will
35 be a solid piece after the mold is opened.

Note that all features, embodiments, method, step, etc., can be applied to any other embodiment described herein. In addition, all features, embodiments, methods, steps, etc., can
40 be combined with any other without limitation. In addition, all paddles herein are (unless stated otherwise) symmetrical, that is the back side/surface would be identical to the front side/surface. For any side or portion of any paddle that is not shown or described in the drawings/specification, that side or portion can be identical (symmetrical) to its corresponding side or portion that has been shown (or identical/
45 symmetrical to other paddles shown herein). For example, if the left side of a paddle is shown, if the right side of the paddle is not shown or described, it can be assumed that the appearance and structure of the right side is identical to the
50 left. If the bottom of a paddle is not shown, it can be assumed that the bottom of that paddle is identical to a bottom shown of any other paddle shown herein. As such, parts and structures described herein can be combined and mixed
55 without limitation. The same would hold true for front and back surfaces, etc. Any part mentioned or illustrated can be made from any suitable material, including any material mentioned herein.

The many features and advantages of the invention are
60 apparent from the detailed specification and, thus, it is intended by the appended claims to cover all such features and advantages of the invention that fall within the true spirit and scope of the invention. Further, since numerous modifications and changes will readily occur to those skilled in
65 the art, it is not desired to limit the invention to the exact construction and operation illustrated and described, and

12

accordingly all suitable modifications and equivalents may be resorted to, falling within the scope of the invention.

What is claimed is:

1. A pickleball paddle, comprising:
 - a front surface;
 - a back surface opposing the front surface;
 - a core disposed between the front surface and the back surface, the core having an outer boundary including:
 - (i) a first portion shaped and dimensioned to terminate internal to, and spaced apart from, an internal perimeter of the pickleball paddle, and (ii) a second portion shaped and dimensioned to terminate closer to the internal perimeter of the pickleball paddle relative to the first portion;
 - a gap formed as a void external to the core and positioned between the outer boundary of the core and the internal perimeter of the pickleball paddle, the gap extending around at least the first portion of the outer boundary of the core;
 - a first filler disposed within at least a portion of the gap beyond the outer boundary of the core;
 - a frame disposed about at least a head portion of the pickleball paddle along an edge portion thereof, the frame at least partially disposed between the front surface and the back surface along the edge portion, the frame defining a hollow interior portion; and
 - a second filler disposed within at least a portion of the hollow interior portion of the frame.
2. The pickleball paddle of claim 1, wherein one or more of the first filler and the second filler includes a foam material.
3. The pickleball paddle of claim 1, wherein one or more of the first filler and the second filler include at least one of: a polymer, a thermoplastic, a thermoset material, a thermoplastic elastomer, an elastomer, a rubber, and an expandable material.
4. The pickleball paddle of claim 1, wherein one or more of the first filler and the second filler includes pressurized air.
5. The pickleball paddle of claim 1, wherein the second filler and the first filler are the same material.
6. The pickleball paddle of claim 1, wherein the second filler and the first filler are different materials.
7. The pickleball paddle of claim 1, wherein the gap is disposed, at least in part, between the frame and the core.
8. The pickleball paddle of claim 7, wherein the gap borders the frame.
9. The pickleball paddle of claim 1, wherein the frame surrounds the entire pickleball paddle.
10. The pickleball paddle of claim 1, wherein the frame include carbon fiber.
11. The pickleball paddle of claim 1, wherein the frame is a hollow cuboid structure.
12. The pickleball paddle of claim 11, wherein the hollow cuboid structure is formed from a single piece of material.
13. The pickleball paddle of claim 1, wherein the core at least partially includes a honeycomb structure.
14. The pickleball paddle of claim 1, further comprising an edge guard covering at least a portion of the frame along at least part of the head portion of the pickleball paddle.
15. The pickleball paddle of claim 1, wherein the outer boundary of the core further includes a third portion connecting the first portion and the second portion, the third portion projecting inwardly away from the internal perimeter of the pickleball paddle.
16. The pickleball paddle of claim 1, wherein the second filler is an expandable foam.

US 12,465,826 B2

13

14

17. The pickleball paddle of claim 1, wherein the second filler is air.

18. The pickleball paddle of claim 1, wherein the first filler includes a vibration dampener.

19. The pickleball paddle of claim 1, wherein the first filler partially fills the gap.

20. The pickleball paddle of claim 1, wherein the frame defines an airtight structure.

* * * * *

EXHIBIT 2

**Exhibit 2 to Complaint
Infringement Claim Chart
U.S. Patent No. 12,465,826**

**Friday Labs LLC
Fever 102**

The exemplary claim chart set forth below is provided based on information to date and may not be exhaustive. Plaintiff's investigation is ongoing. Plaintiff reserves the right to supplement and/or amend this exemplary infringement contention claim chart to identify additional asserted claims, accused products/instrumentalities, and/or to further identify where each element of each asserted claim is found in each accused product. For example, Plaintiff reserves the right to supplement and/or amend this exemplary infringement contention chart in view of any future discovery obtained from Defendant and/or third parties during the pendency of this litigation.

As used in claim chart below, the "Friday Accused Product(s)" include without limitation the following: the pickleball game paddles produced by Defendant Friday Labs LLC (hereinafter "Friday") including, but not necessarily limited to, Friday Fever 102, as well as any other Friday product that shares a similar structure/configuration and/or operates in a manner consistent with the theory of infringement outlined in the claim chart below. Plaintiff contends that the Friday Accused Product(s)—which is also herein referred to as the "Friday Fever 102"—practices each of the claims of U.S. Patent No. 12,465,826 ("the '826 Patent") identified in the claim chart below in the manner shown and/or explained.

The Friday Accused Product(s)—along with the associated photographs and documents—discussed, cited, and/or otherwise referenced herein are representative in all material aspects of all other Accused Product(s) identified herein.

	U.S. Patent No. 12,465,826	Friday Fever 102
	Claim1	
<p>1 [pre]</p>	<p>A pickleball paddle, comprising:</p>	<p>The Friday Fever 102 Paddle is a pickleball paddle. See https://fridaypickle.com/products/fever-102-elongated.</p> 

	U.S. Patent No. 12,465,826	Friday Fever 102
1.a	a front surface;	<p>The Friday Fever 102 Paddle includes a front surface (labeled A, below):</p> 

	U.S. Patent No. 12,465,826	Friday Fever 102
1.b	a back surface opposing the front surface;	<p>The Friday Fever 102 Paddle includes a back surface (labeled B, below) opposing the front surface:</p> 

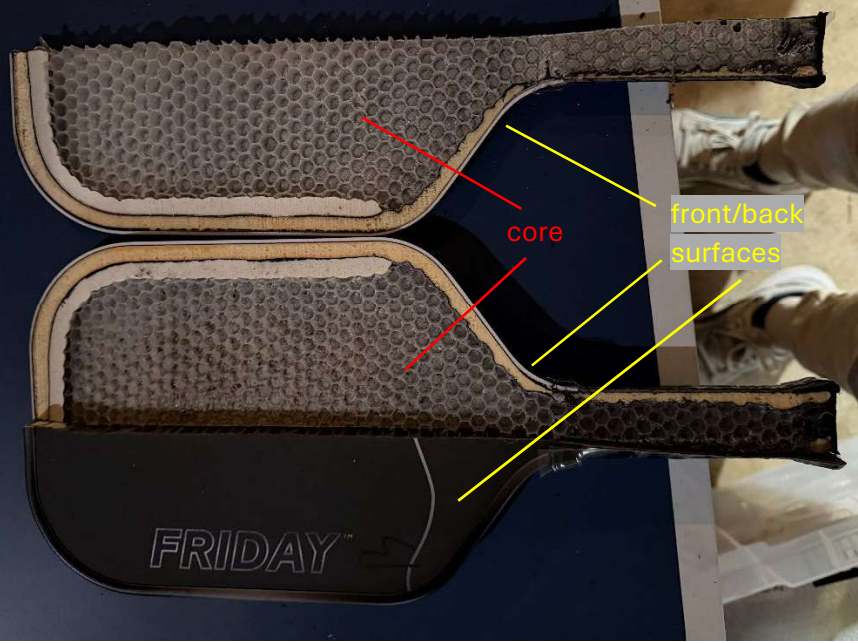
	U.S. Patent No. 12,465,826	Friday Fever 102
<p>1.c</p>	<p>a core disposed between the front surface and the back surface,</p>	<p>The Friday Fever 102 Paddle includes a core disposed between the front surface and the back surface, specifically a polypropylene core. https://fridaypickle.com/products/fever-102?srsltid=AfmBOoqt1kyx4QHxEzeLZwljswHCHX7Eggogb-i6JoTsnwGgSOZ3OHw.</p>  <p>The image shows a cross-section of a paddle with a honeycomb core. Red lines point to the core, and yellow lines point to the front and back surfaces. The word 'FRIDAY' is visible on the bottom surface of the paddle.</p>

	U.S. Patent No. 12,465,826	Friday Fever 102
		 <p data-bbox="982 678 1854 748">See https://www.facebook.com/fridaypickleball/videos/game-changing-paddle-under-100/2143220182753242/.</p>
<p>1.d</p>	<p>the core having an outer boundary including a first portion shaped and dimensioned to terminate internal to, and spaced apart from, an internal perimeter of the pickleball paddle, and a second portion shaped and dimensioned to terminate closer to the internal perimeter of the pickleball paddle relative to the first portion</p>	<p>The Friday Fever 102 Paddle includes a core having an outer boundary including a first portion shaped and dimensioned to terminate internal to, and spaced apart from, an internal perimeter of the pickleball paddle, and a second portion shaped and dimensioned to terminate closer to the internal perimeter of the pickleball paddle relative to the first portion:</p>

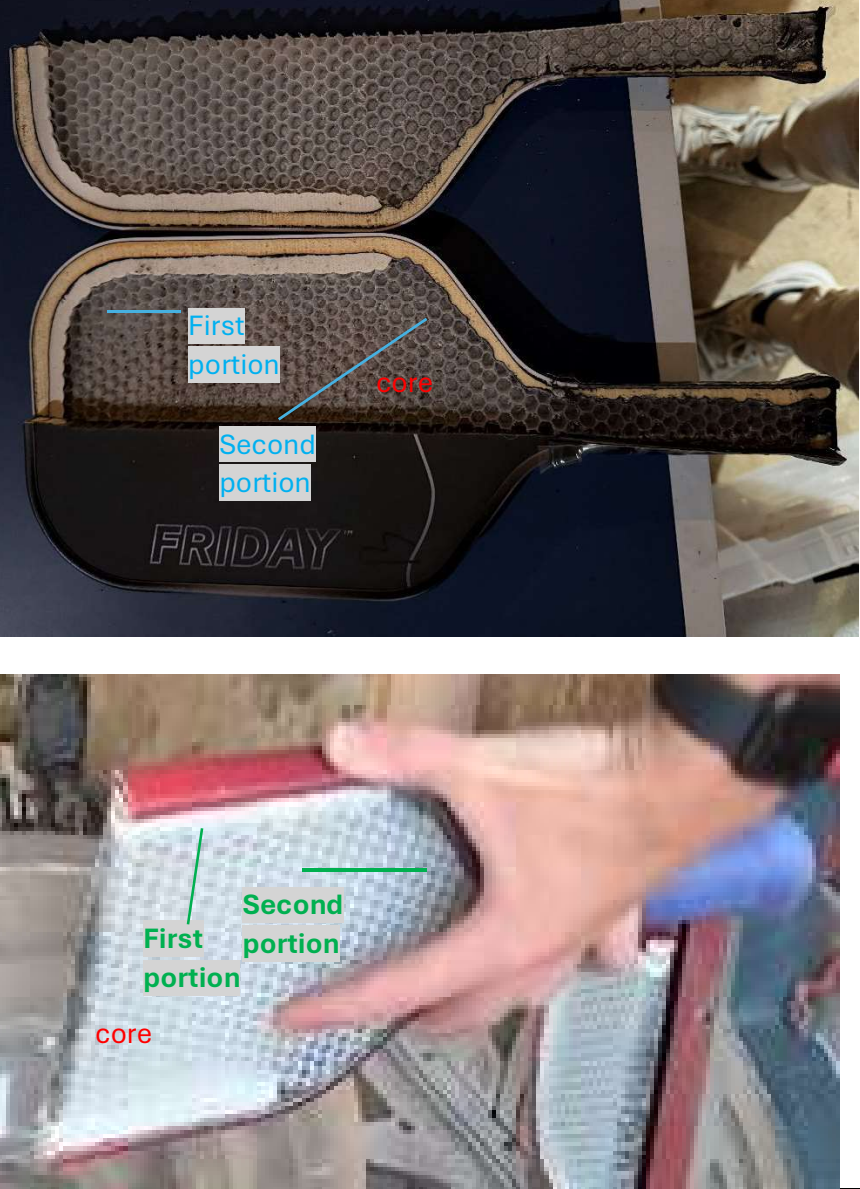
	U.S. Patent No. 12,465,826	Friday Fever 102
		 <p>The image contains two photographs of shoe sole cross-sections. The top photograph shows a dark-colored sole with a honeycomb-patterned core. A blue line points to the upper part of the core, labeled 'First portion'. A red line points to the lower part of the core, labeled 'core'. A blue line points to the lower part of the sole, labeled 'Second portion'. The word 'FRIDAY' is embossed on the sole. The bottom photograph shows a lighter-colored sole with a similar honeycomb core. A green line points to the upper part of the core, labeled 'First portion'. A green line points to the lower part of the core, labeled 'Second portion'. A red line points to the lower part of the sole, labeled 'core'.</p>

	U.S. Patent No. 12,465,826	Friday Fever 102
		<p>See https://www.facebook.com/fridaypickleball/videos/game-changing-paddle-under-100/2143220182753242/.</p>  <p>See https://fridaypickle.com/products/fever-102?srsltid=AfmBOoqt1kyx4QHxEzeLZwljswHCHX7Eqgogb-i6JoTsnwGgSOZ3OHw.</p>
	<p>a gap formed as a void external to the core and positioned between the outer boundary of the core and the internal perimeter of the pickleball paddle,</p>	<p>The Friday Fever 102 Paddle includes a gap formed as a void external to the core and positioned between the outer boundary of the core and the internal perimeter of the pickleball paddle:</p>

	U.S. Patent No. 12,465,826	Friday Fever 102
1.e		 <p>The photograph shows a cross-section of a shoe sole. The sole is composed of several layers. The top layer is a dark, textured material. Below it is a layer of a lighter, porous material with a honeycomb-like structure. A green arrow points to a small space between the porous layer and the layer below it, labeled 'gap'. The sole is shown in two positions: one showing the top view and one showing the bottom view. The bottom view shows the word 'FRIDAY' embossed on the sole. The shoe is placed on a dark surface, and a person's foot wearing a white sneaker is visible in the background.</p>

	U.S. Patent No. 12,465,826	Friday Fever 102
		 <p>See https://fridaypickle.com/products/fever-102?srsltid=AfmBOoqt1kyx4QHXEzeLZwljswHCHX7Eqgogb-i6JoTsnwGgSOZ3OHw.</p>
	<p>the gap extending around at least the first portion of the outer boundary of the core;</p>	<p>The Friday Fever 102 Paddle includes a gap extending around at least the first portion of the outer boundary of the core:</p>

	U.S. Patent No. 12,465,826	Friday Fever 102
1.f		 <p>The photograph shows a cross-section of a paddle core. The core is composed of a honeycomb-like structure. A blue line points to a section of the core labeled 'First portion'. A green line points to a space between the core and the outer shell labeled 'gap'. The paddle is dark-colored with the word 'FRIDAY' visible on the face.</p>
1.g	<p>a first filler disposed within at least a portion of the gap beyond the outer boundary of the core;</p>	<p>The Friday Fever 102 Paddle includes a first filler disposed within at least a portion of the gap beyond the outer boundary of the core:</p>

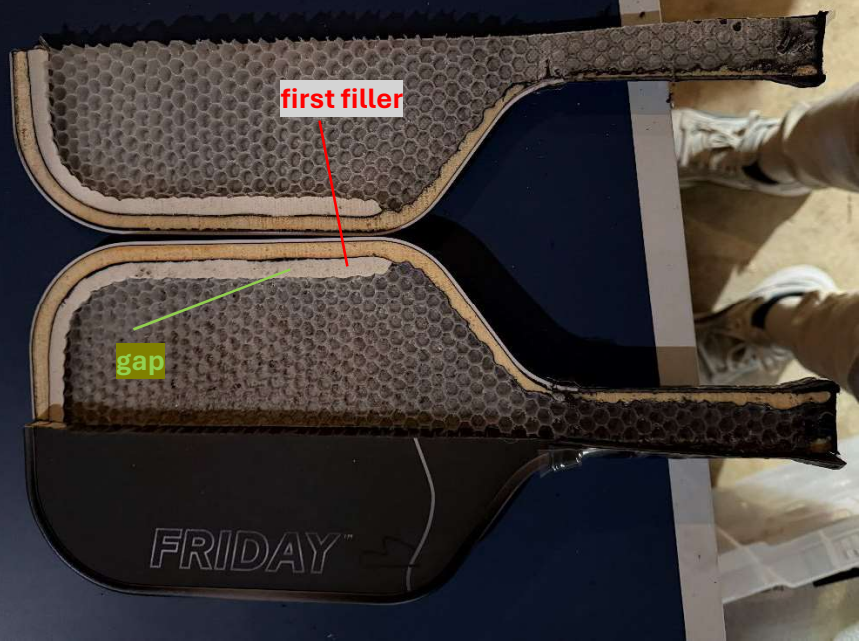
	U.S. Patent No. 12,465,826	Friday Fever 102
		 <p>The photograph shows a cross-section of a pickleball paddle head. The top portion is filled with a porous, honeycomb-like material. A red label 'first filler' points to this material. Below it, a green label 'gap' points to a distinct layer or void between the porous material and the inner frame. The paddle is dark-colored with 'FRIDAY' embossed on the bottom edge.</p>
<p>1.h</p>	<p>a frame disposed about at least a head portion of the pickleball paddle along an edge portion thereof,</p>	<p>The Friday Fever 102 Paddle includes a frame disposed about at least a head portion of the pickleball paddle along an edge portion thereof:</p>

	U.S. Patent No. 12,465,826	Friday Fever 102
		 <p>The photograph shows a paddle with a honeycomb core. A yellow circle highlights the central portion of the paddle. A purple line points from the word 'frame' to the edge of the paddle. A yellow box highlights the word 'head' on the honeycomb surface. The word 'FRIDAY' is embossed on the black face of the paddle.</p>
<p>1.i</p>	<p>the frame at least partially disposed between the front surface and the back surface along the edge portion,</p>	<p>The Friday Fever 102 Paddle includes a frame at least partially disposed between the front surface and the back surface along the edge portion:</p>

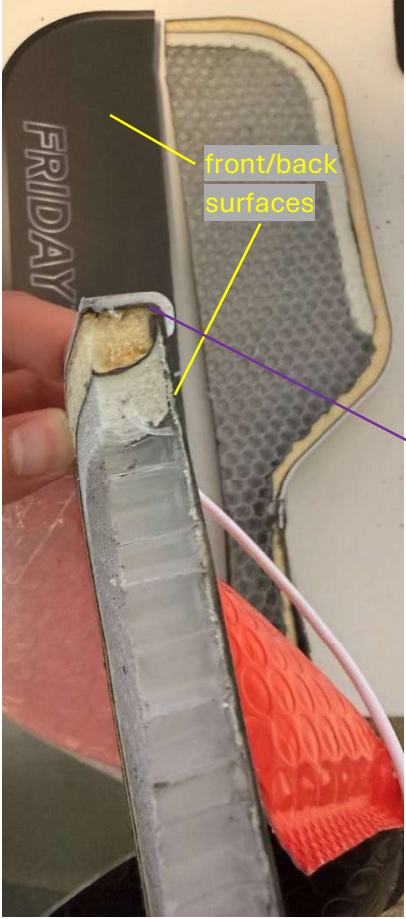
	U.S. Patent No. 12,465,826	Friday Fever 102
		
<p>1.j</p>	<p>the frame defining a hollow interior portion; and</p>	<p>The Friday Fever 102 Paddle includes a frame defining a hollow interior portion:</p>

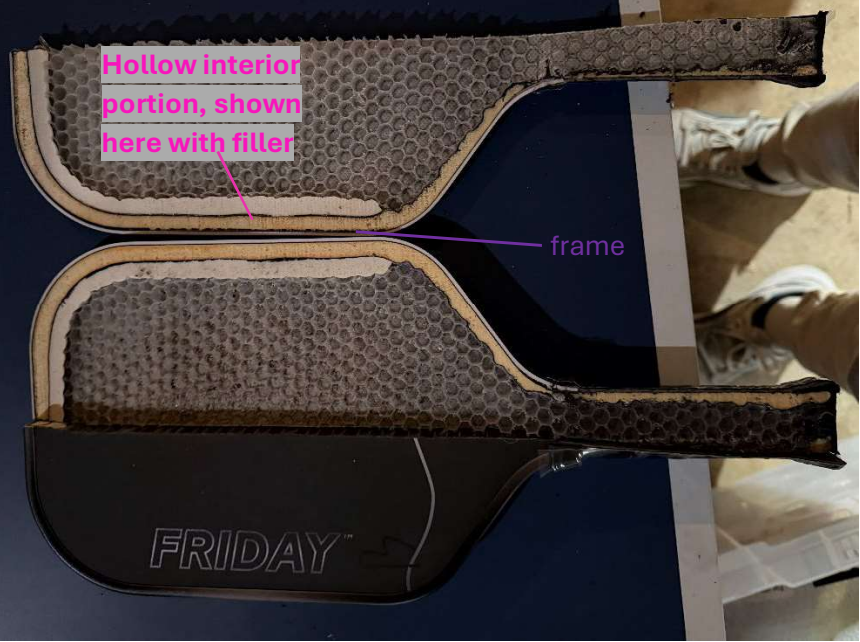
	U.S. Patent No. 12,465,826	Friday Fever 102
		 <p>The photograph shows a wine glass with a honeycomb-patterned frame. A pink label points to the interior of the frame, stating "Hollow interior portion, shown here with filler". A purple label points to the frame itself, stating "frame". The word "FRIDAY" is embossed on the glass. The glass is shown in a cutaway view, revealing the internal structure.</p>

	U.S. Patent No. 12,465,826	Friday Fever 102
1.k	<p>a second filler disposed within at least a portion of the hollow interior portion of the frame.</p>	<p>The Friday Fever 102 Paddle includes a second filler disposed within at least a portion of the hollow interior portion of the frame:</p> 