

**IN THE UNITED STATES DISTRICT COURT
FOR THE SOUTHERN DISTRICT OF FLORIDA**

Sport Squad, Inc. d/b/a JOOLA,
a Maryland corporation

Plaintiff,

v.

**Vegas Pickleball, LLC d/b/a RPM
Pickleball,**
a Florida corporation

Defendant.

Civil Action No. _____

JURY TRIAL DEMANDED

COMPLAINT FOR PATENT INFRINGEMENT

Plaintiff Sport Squad, Inc. d/b/a JOOLA (“JOOLA” or “Plaintiff”) files this complaint for patent infringement against Vegas Pickleball, LLC d/b/a RPM Pickleball (“RPM” or “Defendant”) and alleges as follows:

NATURE OF THE ACTION

1. This is a civil action for patent infringement arising under the patent laws of the United States, 35 U.S.C. § 1 *et. seq.*, from RPM’s infringement of U.S. Patent No. 12,465,826 (the “’826 Patent”) and U.S. Patent No. 12,357,891 (the “’891 Patent”) (collectively the “Asserted Patents”).

THE PARTIES

2. Plaintiff Sport Squad, Inc. d/b/a JOOLA is a corporation organized under the laws of Maryland with its principal operating business located at 915 Meeting Street, North Bethesda, Maryland 20852.

3. Defendant Vegas Pickleball, LLC d/b/a RPM Pickleball is a limited liability company organized under the laws of Florida with its principal place of business at 1075 Anchor Point, Delray Beach, Florida 33444 and a registered agent, James Ignatowich, at 1075 Anchor Point, Delray Beach, Florida 33444.

4. On information and belief, RPM manufactures, imports, offers for sale, and sells pickleball paddles to resellers, distributors, and consumers throughout the United States, including in this District.

JURISDICTION AND VENUE

5. This Court has subject matter jurisdiction pursuant to 28 U.S.C. §§ 1331 and 1338(a) because the claims herein arise under the patent laws of the United States, 35 U.S.C. § 1 *et seq.*, including 35 U.S.C. § 271.

6. This Court has personal jurisdiction over RPM insofar as RPM is organized in this District, and maintains a regular and established place of business at 1075 Anchor Point, Delray Beach, Florida 33444.

7. RPM engages in other persistent courses of conduct and derives substantial revenue from products or services and continuous contacts within this District, has purposefully established substantial, systematic, and continuous contacts within this District, and should reasonably expect to be sued in a court in this District.

8. RPM regularly transacts business in the State of Florida and within this District, including a permanent and significant presence in this District.

9. The Court’s exercise of jurisdiction over RPM will not offend traditional notions of fair play and substantial justice.

10. Venue in this District is proper is proper pursuant to 28 U.S.C. §§ 1391(b), (c) and 1400(b).

FIRST CLAIM FOR RELIEF

(Patent Infringement—35 U.S.C. § 271)

INFRINGEMENT OF U.S. PATENT NO. 12,465,826

11. JOOLA realleges and incorporates by reference each of its allegations in paragraphs 1-10 of this Complaint.

12. On November 11, 2025, the U.S. Patent and Trademark Office (“USPTO”) duly and legally issued the ’826 Patent, entitled “Game Paddle.” A true and correct copy of the ’826 Patent is attached as **Exhibit 1**.

13. The’826 Patent describes a solid sports paddle, such as a pickleball paddle, and methods of manufacturing it with internal structures designed to affect the paddle’s feel and performance during play. The technology described in the ’826 Patent is implemented in infringing pickleball paddles including, but not limited to, the RPM Friction Pro Paddle (“Accused Product”).

14. RPM has infringed and continues to infringe the ’826 Patent by making, using, selling, offering to sell, and/or importing products including, but not limited to, the RPM Friction Pro Paddle.

15. Throughout its infringement, RPM has had actual knowledge of JOOLA's '826 Patent and of RPM's infringement of the '826 Patent.

16. JOOLA has not licensed or otherwise authorized RPM to make, use, offer for sale, sell, or import any products that embody the inventions of the '826 Patent.

17. As shown in the attached non-limiting claim chart (**Exhibit 2**), by making, using (at least by testing), selling, offering for sale, and/or importing the Accused Product in this Judicial District and throughout the United States without license or authorization, RPM is now and has been directly infringing at least claim 1 of the '826 Patent, either literally or under the doctrine of equivalents, as proscribed by 35 U.S.C. § 271, *et seq.*

18. Exhibit 2 is intended solely to satisfy the notice requirements of Federal Rule of Civil Procedure 8(a)(2), and does not represent JOOLA's preliminary or final infringement contentions or preliminary or final claim construction positions. JOOLA reserves the right to modify its infringement theories reflected in Exhibit 2 as discovery progresses in this case, including through contentions disclosures and claim construction in accordance with the Patent Local Rules in this District.

19. As a direct and proximate result of RPM's direct infringement of the '826 Patent, JOOLA has been and continues to be damaged. RPM's infringing activities will continue unless enjoined by this Court or until the patent expires, whichever is sooner.

20. By engaging in the conduct described herein, RPM has injured JOOLA and is thus liable for infringement of the '826 Patent, pursuant to 35 U.S.C. § 271.

21. RPM has committed and continues to commit acts of infringement that RPM actually knew or should have known constituted an unjustifiably high risk of infringement of at least one valid and enforceable claim of the '826 Patent. RPM's direct infringement of the '826

Patent has been and continues to be willful, intentional, deliberate, or in conscious disregard of rights under the patent. JOOLA is entitled to an award of treble damages, reasonable attorney fees, and costs in bringing this action.

SECOND CLAIM FOR RELIEF

(Patent Infringement—35 U.S.C. § 271)

INFRINGEMENT OF U.S. PATENT NO. 12,347,891

22. JOOLA realleges and incorporates by reference each of its allegations in paragraphs 1-10 of this Complaint.

23. On July 15, 2025, the U.S. Patent and Trademark Office (“USPTO”) duly and legally issued the ’891 Patent, entitled “Game Paddle.” A true and correct copy of the ’891 Patent is attached as **Exhibit 3**.

24. The ’891 Patent describes a solid sports paddle, such as a pickleball paddle, and methods of manufacturing it with internal structures designed to affect the paddle’s feel and performance during play. The technology described in the ’891 Patent is implemented in infringing pickleball paddles including, but not limited to, the RPM Friction Pro Paddle (“Accused Product”).

25. RPM has infringed and continues to infringe the ’891 Patent making, using, selling, offering to sell, and/or importing products including, but not limited to, the RPM Friction Pro Paddle.

26. Throughout its infringement, RPM has had actual knowledge of JOOLA’s ’891 Patent and of RPM’s infringement of the ’891 Patent.

27. JOOLA has not licensed or otherwise authorized RPM to make, use, offer for sale, sell, or import any products that embody the inventions of the ’891 Patent.

28. As shown in the attached non-limiting claim chart (**Exhibit 4**), by making, using (at least by testing), selling, offering for sale, and/or importing the Accused Product in this Judicial District and throughout the United States without license or authorization, RPM is now and has been directly infringing at least claim 1 of the '891 Patent, either literally or under the doctrine of equivalents, as proscribed by 35 U.S.C. § 271, *et seq.*

29. Exhibit 4 is intended solely to satisfy the notice requirements of Federal Rule of Civil Procedure 8(a)(2), and does not represent JOOLA's preliminary or final infringement contentions or preliminary or final claim construction positions. JOOLA reserves the right to modify its infringement theories reflected in Exhibit 4 as discovery progresses in this case, including through contentions disclosures and claim construction in accordance with the Patent Local Rules in this District.

30. As a direct and proximate result of RPM's direct infringement of the '891 Patent, JOOLA has been and continues to be damaged. RPM's infringing activities will continue unless enjoined by this Court or until the patent expires, whichever is sooner.

31. By engaging in the conduct described herein, RPM has injured JOOLA and is thus liable for infringement of the '891 Patent, pursuant to 35 U.S.C. § 271.

32. RPM has committed and continues to commit acts of infringement that RPM actually knew or should have known constituted an unjustifiably high risk of infringement of at least one valid and enforceable claim of the '891 Patent. RPM's direct infringement of the '891 Patent has been and continues to be willful, intentional, deliberate, or in conscious disregard of rights under the patent. JOOLA is entitled to an award of treble damages, reasonable attorney fees, and costs in bringing this action.

PRAYER FOR RELIEF

WHEREFORE, JOOLA prays for the following relief against RPM as follows:

A. Entry of judgment declaring that RPM has infringed one or more claims of the '826 Patent;

B. Entry of judgment declaring that RPM has infringed one or more claims of the '891 Patent;

C. Entry of judgment declaring that RPM infringement of the '826 Patent has been willful and deliberate;

D. Entry of judgment declaring that RPM infringement of the '891 Patent has been willful and deliberate;

E. An order pursuant to 35 U.S.C. § 283 permanently enjoining RPM, their officers, agents, servants, employees, attorneys, and those persons in active concert or participation with them, from further acts of infringement of the '826 Patent;

F. An order pursuant to 35 U.S.C. § 283 permanently enjoining RPM, their officers, agents, servants, employees, attorneys, and those persons in active concert or participation with them, from further acts of infringement of the '891 Patent;

G. An order awarding damages sufficient to compensate JOOLA for RPM's infringement of the '826 Patent, but in no event less than a reasonable royalty, together with interest and costs;

H. An order awarding damages sufficient to compensate JOOLA for RPM's infringement of the '891 Patent, but in no event less than a reasonable royalty, together with interest and costs;

I. An order awarding JOOLA treble damages under 35 U.S.C. § 284 as a result of RPM's willful and deliberate infringement of the '826 Patent;

J. An order awarding JOOLA treble damages under 35 U.S.C. § 284 as a result of RPM's willful and deliberate infringement of the '891 Patent;

K. Entry of judgment declaring that this case is exceptional and awarding JOOLA its costs and reasonable attorney fees under 35 U.S.C. § 285; and

L. Such other and further relief as this Court may deem just and proper.

JURY TRIAL DEMAND

Pursuant to Fed. R. Civ. P. 38(b), Plaintiff requests a trial by jury of all issues so triable.

DATED: April 9, 2026

Respectfully submitted,

By: /s/ Jonathan B. Morton
Jonathan B. Morton (FBN 956872)
jonathan.morton@klgates.com
K&L Gates LLP
200 South Biscayne Boulevard, Suite 3900
Miami, Florida 33131
Telephone: (305) 539-3357

Nicholas F. Lenning (*pro hac vice forthcoming*)
nicholas.lenning@klgates.com
K&L Gates LLP
925 Fourth Avenue, Suite 2900
Seattle, Washington 98104
Telephone: (206) 623-7580

Jason A. Engel (*pro hac vice forthcoming*)
jason.engel@klgates.com
Austin C. Holler (*pro hac vice forthcoming*)
austin.holler@klgates.com
Devdhi Kasana (*pro hac vice forthcoming*)
devdhi.kasana@klgates.com
Kahlan E. Noel (*pro hac vice forthcoming*)
kahlan.noel@klgates.com
K&L Gates LLP
70 W. Madison Street, Suite 3300
Chicago, Illinois 60602
Telephone: (312) 372-1121

Rachel Berman (*pro hac vice forthcoming*)
rachel.berman@klgates.com
K&L Gates LLP
10100 Santa Monica Blvd.,
8th Floor
Los Angeles, California 90067
Telephone: (310) 552-5000

*Attorneys for Plaintiff Sport Squad, Inc. D/B/A
JOOLA*

EXHIBIT 1



(12) **United States Patent**
Kachiwazaki et al.

(10) **Patent No.:** **US 12,465,826 B2**
 (45) **Date of Patent:** **Nov. 11, 2025**

(54) **GAME PADDLE**

(71) Applicant: **Sport Squad, Inc.**, Rockville, MD (US)

(72) Inventors: **Fabio Kachiwazaki**, São Paulo (BR);
Austin Kim, Columbia, MD (US);
Richard Lee, Potomac, MD (US)

(73) Assignee: **Sport Squad, Inc.**, North Bethesda, MD (US)

(*) Notice: Subject to any disclaimer, the term of this patent is extended or adjusted under 35 U.S.C. 154(b) by 0 days.

(21) Appl. No.: **19/027,671**

(22) **Filed:** **Jan. 17, 2025**

(65) **Prior Publication Data**
 US 2025/0161771 A1 May 22, 2025

Related U.S. Application Data

(63) Continuation of application No. 18/389,174, filed on Nov. 13, 2023.
 (Continued)

(51) **Int. Cl.**
A63B 59/42 (2015.01)
A63B 60/54 (2015.01)
 (Continued)

(52) **U.S. Cl.**
 CPC **A63B 59/42** (2015.10); **B32B 3/08** (2013.01); **B32B 3/12** (2013.01); **B32B 5/02** (2013.01); **B32B 5/18** (2013.01); **A63B 60/54** (2015.10); **A63B 2209/02** (2013.01); **B32B 2262/106** (2013.01); **B32B 2266/0214** (2013.01)

(58) **Field of Classification Search**

CPC **B32B 3/08**; **B32B 3/12**; **B32B 5/18**; **B32B 2262/106**; **B32B 2266/0214**; **A63B 59/42**; **A63B 2209/00**; **A63B 2209/02**; **A63B 60/54**

See application file for complete search history.

(56) **References Cited**

U.S. PATENT DOCUMENTS

3,879,035 A * 4/1975 Danchulis A63B 59/40 473/527
 3,949,988 A 4/1976 Stauffer
 (Continued)

FOREIGN PATENT DOCUMENTS

CA 3038087 A 9/2020
 CN 219167665 U 6/2023
 (Continued)

OTHER PUBLICATIONS

Image of cutaway of Selkirk LABS Project 002 paddle (Aug. 2023), 1 page.

(Continued)

Primary Examiner — Eugene L Kim
Assistant Examiner — Amir A Klayman
 (74) *Attorney, Agent, or Firm* — Bass Patent Law, LLC

(57) **ABSTRACT**

The present teachings generally include game paddles such as pickleball paddles. For example, a pickleball paddle disclosed herein may include a first surface, a second surface, and a core disposed therebetween, where the core defines a plurality of gaps that can accommodate one or more fillers, e.g., to provide vibration dampening and/or to otherwise affect performance, comfort, and enjoyment. In some aspects, a frame may also or instead include a filler disposed therein and/or adjacent thereto.

20 Claims, 31 Drawing Sheets

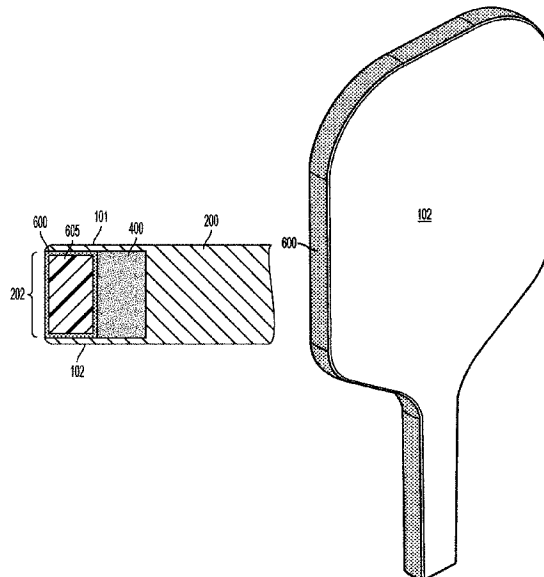

US 12,465,826 B2

Related U.S. Application Data

(60) Provisional application No. 63/543,865, filed on Oct. 12, 2023, provisional application No. 63/535,565, filed on Aug. 30, 2023.

(51) **Int. Cl.**
B32B 3/08 (2006.01)
B32B 3/12 (2006.01)
B32B 5/02 (2006.01)
B32B 5/18 (2006.01)

References Cited

U.S. PATENT DOCUMENTS

4,130,277 A 12/1978 Marks
4,192,506 A * 3/1980 Sofia A63B 60/00
473/548
4,194,738 A * 3/1980 Inoue A63B 49/10
473/535
4,227,692 A * 10/1980 Castelli A63B 60/40
473/525
4,331,331 A * 5/1982 Rodgers, Jr. A63B 60/00
473/544
4,379,554 A 4/1983 Schuyler et al.
5,172,911 A * 12/1992 Chang A63B 60/00
473/521
5,454,562 A * 10/1995 Sommer A63B 60/54
473/523
5,649,873 A * 7/1997 Fuller A63B 53/0466
473/332
5,961,404 A 10/1999 Gormley
9,993,707 B2 * 6/2018 Davis A63B 60/00
10,377,093 B2 8/2019 Filippini
11,597,169 B2 3/2023 Simmons
11,612,792 B2 3/2023 Marshall
12,370,424 B1 * 7/2025 Kim B32B 5/18
2011/0201461 A1 8/2011 Gazzara et al.
2015/0224370 A1 * 8/2015 Yamamoto A63B 49/10
156/185
2017/0021247 A1 * 1/2017 Marvin A63B 59/40
2017/0021248 A1 * 1/2017 Marvin A63B 59/45
2017/0136325 A1 * 5/2017 Fox A63B 59/42
2018/0104555 A1 * 4/2018 Taylor A63B 59/45
2018/0353820 A1 * 12/2018 Davis A63B 59/70
2020/0290243 A1 9/2020 Avnery et al.
2020/0360778 A1 * 11/2020 Lee A63B 60/04

2020/0398130 A1 * 12/2020 Lee A63B 59/42
2021/0252356 A1 8/2021 Thurman et al.
2021/0252357 A1 * 8/2021 Lee A63B 59/42
2021/0260452 A1 8/2021 Zheng
2022/0032141 A1 2/2022 Brents et al.
2022/0040937 A1 2/2022 Simmons
2023/0047371 A1 * 2/2023 Lee A63B 60/00
2023/0149784 A1 5/2023 Lee
2023/0191215 A1 * 6/2023 Barnes A63B 59/42
473/527
2023/0356048 A1 11/2023 Junkins
2023/0415010 A1 * 12/2023 Luo A63B 59/42
2024/0050822 A1 2/2024 Kapheim
2024/0165468 A1 5/2024 Shu
2024/0424366 A1 * 12/2024 Li A63B 59/48
2025/0018264 A1 * 1/2025 Filippini A63B 60/08
2025/0083010 A1 * 3/2025 Meyer B32B 27/12
2025/0114674 A1 * 4/2025 Hudes A63B 59/42
2025/0161772 A1 5/2025 Kachiwazaki et al.

FOREIGN PATENT DOCUMENTS

CN 219701015 U 9/2023
WO WO-2022182992 A1 * 9/2022 A63B 59/42
WO 2022217045 A1 10/2022
WO WO-2024076417 A1 * 4/2024
WO 2025049122 A1 3/2025

OTHER PUBLICATIONS

Selkirk LABS Project 002, website captured by Wayback Machine on Jun. 2, 2022, currently available at <https://www.selkirklabs.com/products/selkirk-labs-project-002> (website capture date is Jun. 2, 2022), 3 pages.
U.S. Appl. No. 63/535,565, filed Aug. 30, 2023, Fabio Kachiwazaki.
U.S. Appl. No. 63/543,865, filed Oct. 12, 2023, Fabio Kachiwazaki.
Gearbox, "Pro Power Elongated," <https://gearboxsports.com/collections/all-pickleball-paddles/products/pro-power-elongated>, 2023, 9 pages.
ISA/EP, PCT Application No. PCT/US24/42535, International Search Report and Written Opinion dated Nov. 12, 2024, 15 pages.
U.S. Appl. No. 19/028,832, Non-Final Office Action dated Mar. 12, 2025, 15 pages.
U.S. Appl. No. 19/028,832, Notice of Allowance dated Apr. 9, 2025, 9 pages.

* cited by examiner

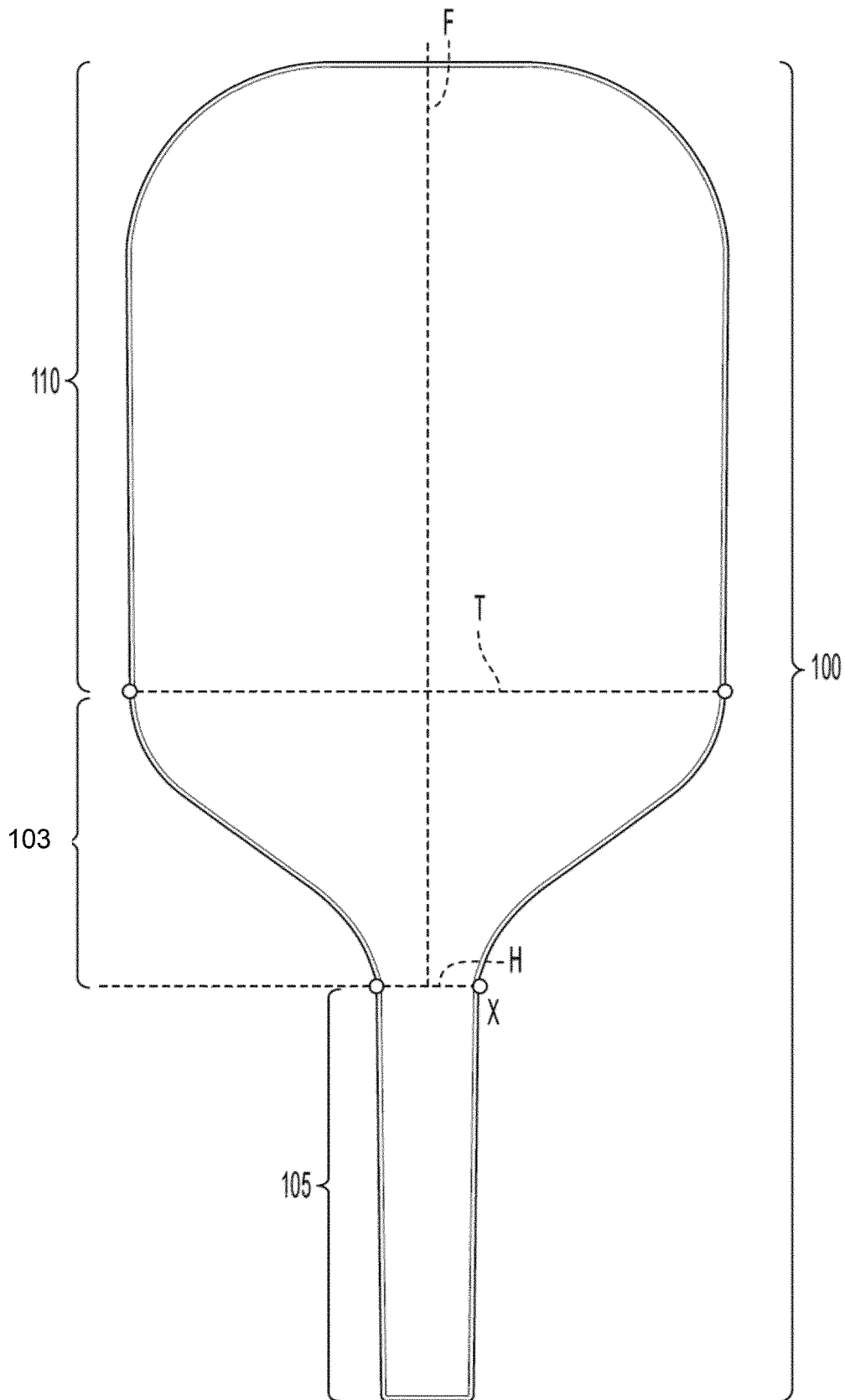

FIG. 1A

U.S. Patent

Nov. 11, 2025

Sheet 2 of 31

US 12,465,826 B2

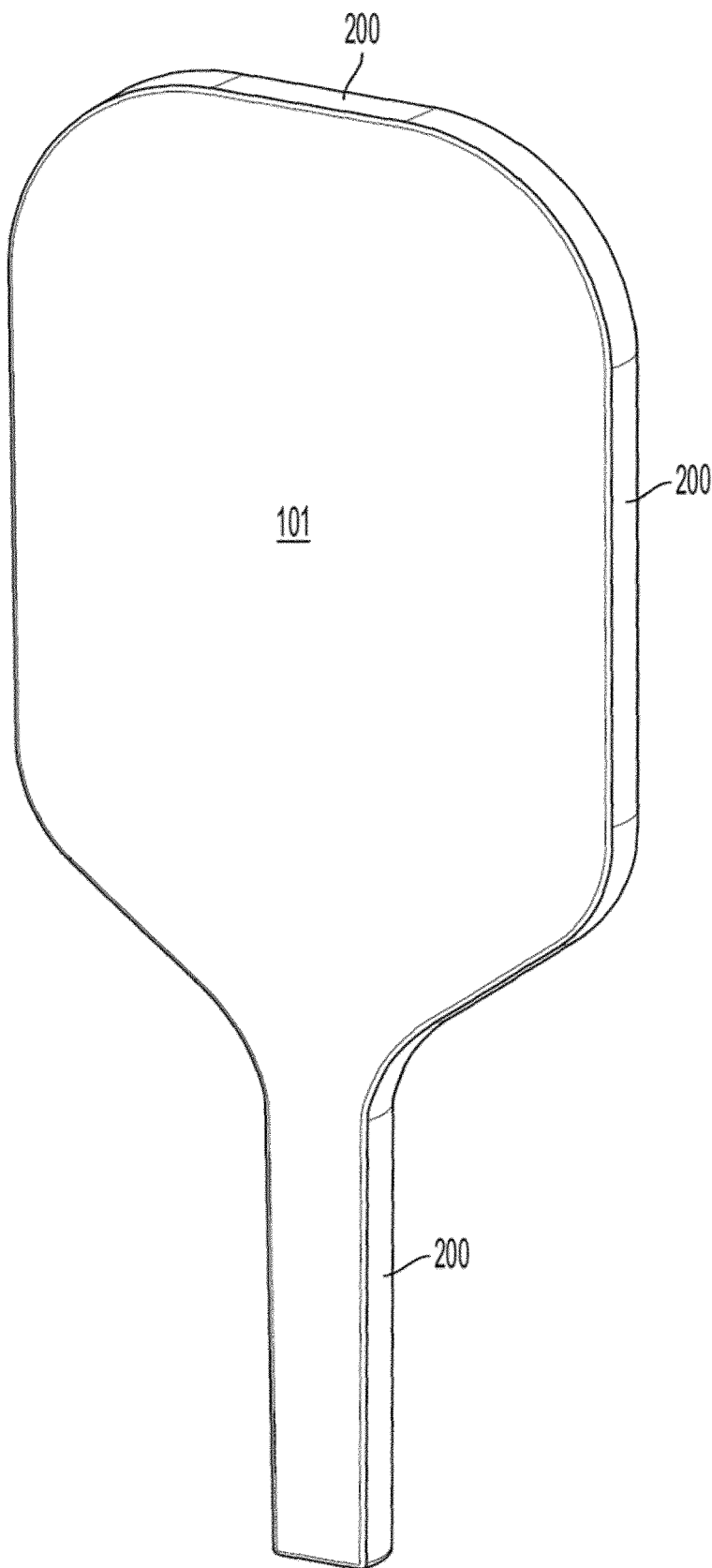

FIG. 1B

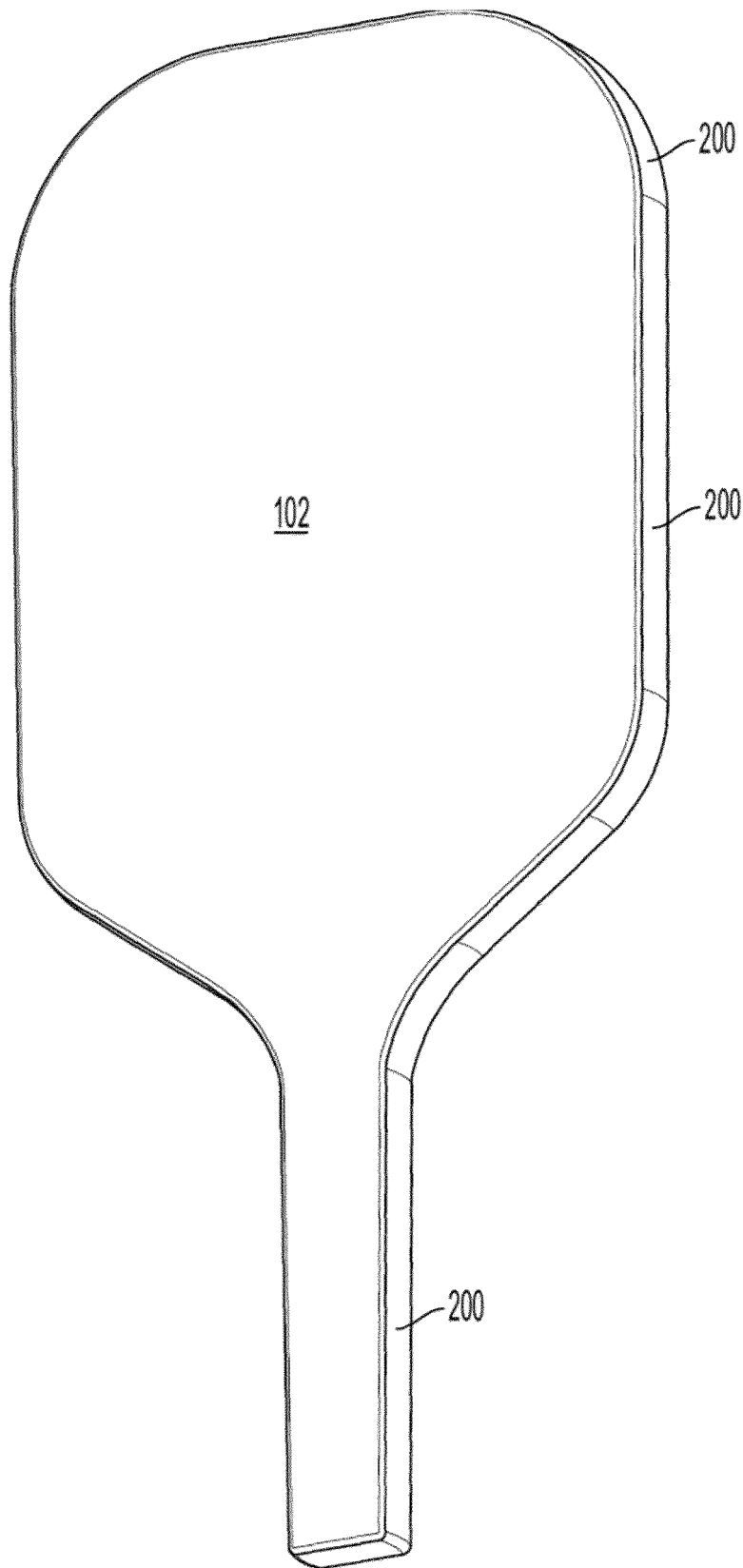

FIG. 1C

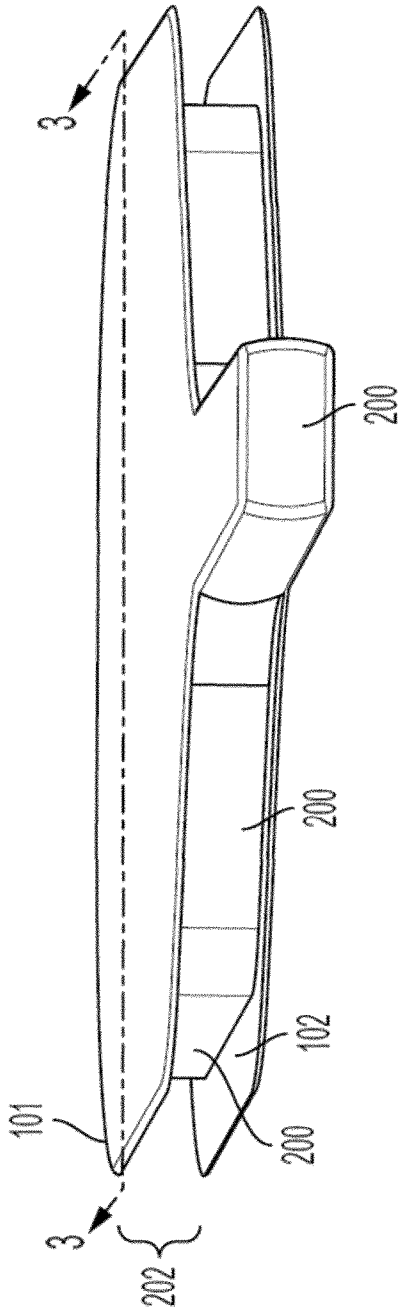

FIG. 2

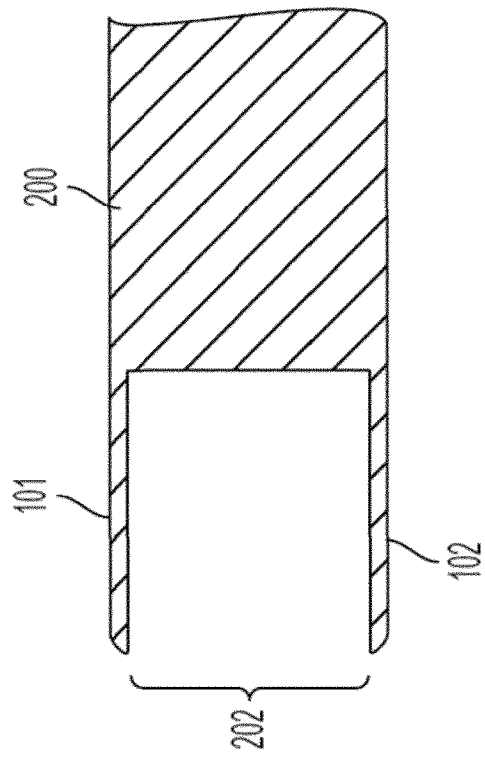

FIG. 3

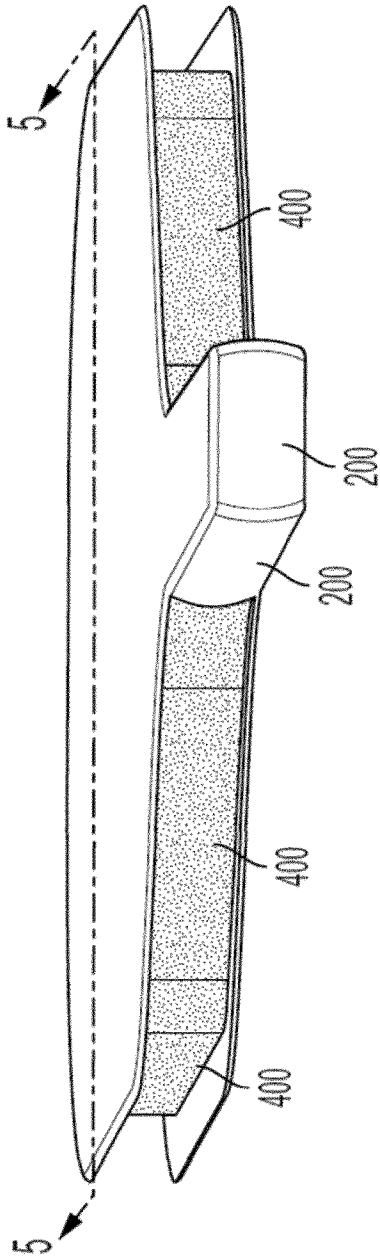

FIG. 4

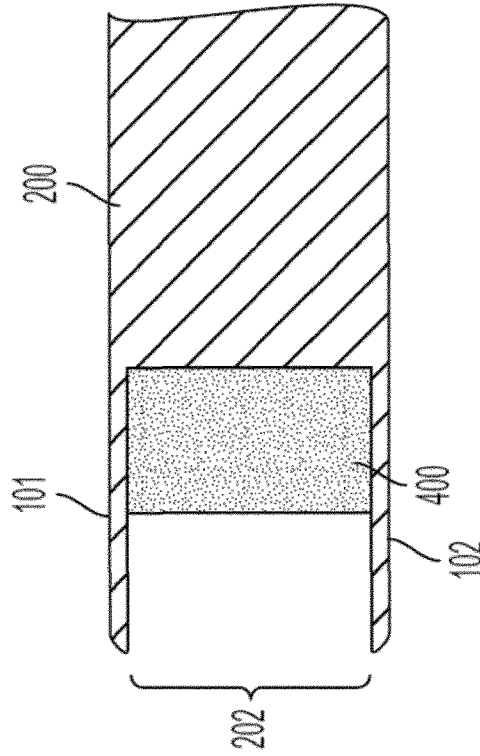

FIG. 5

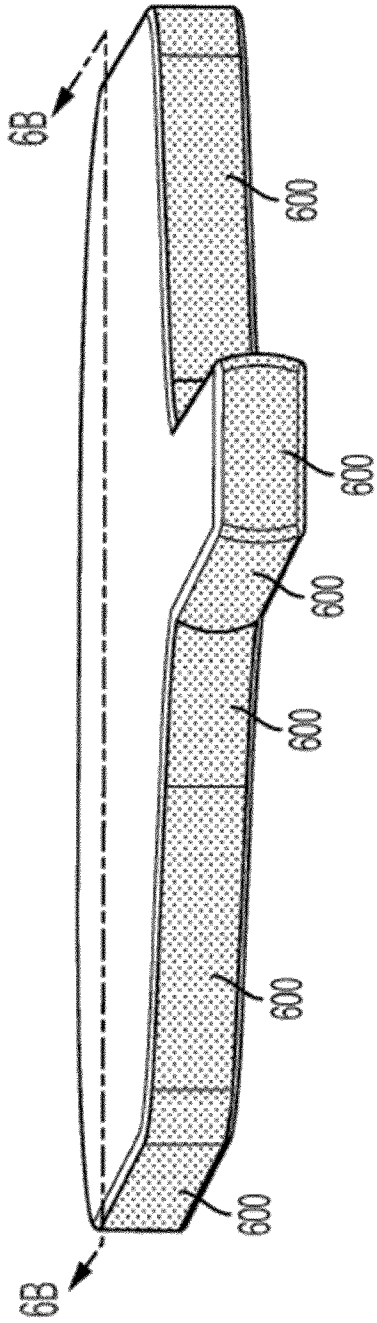

FIG. 6A

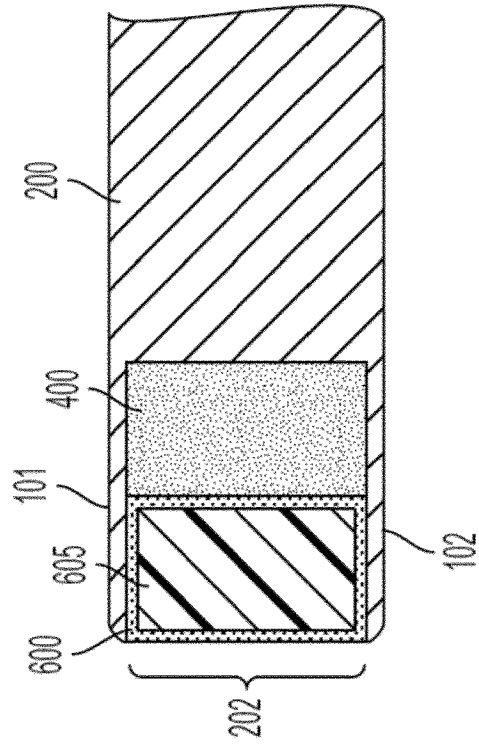

FIG. 6B

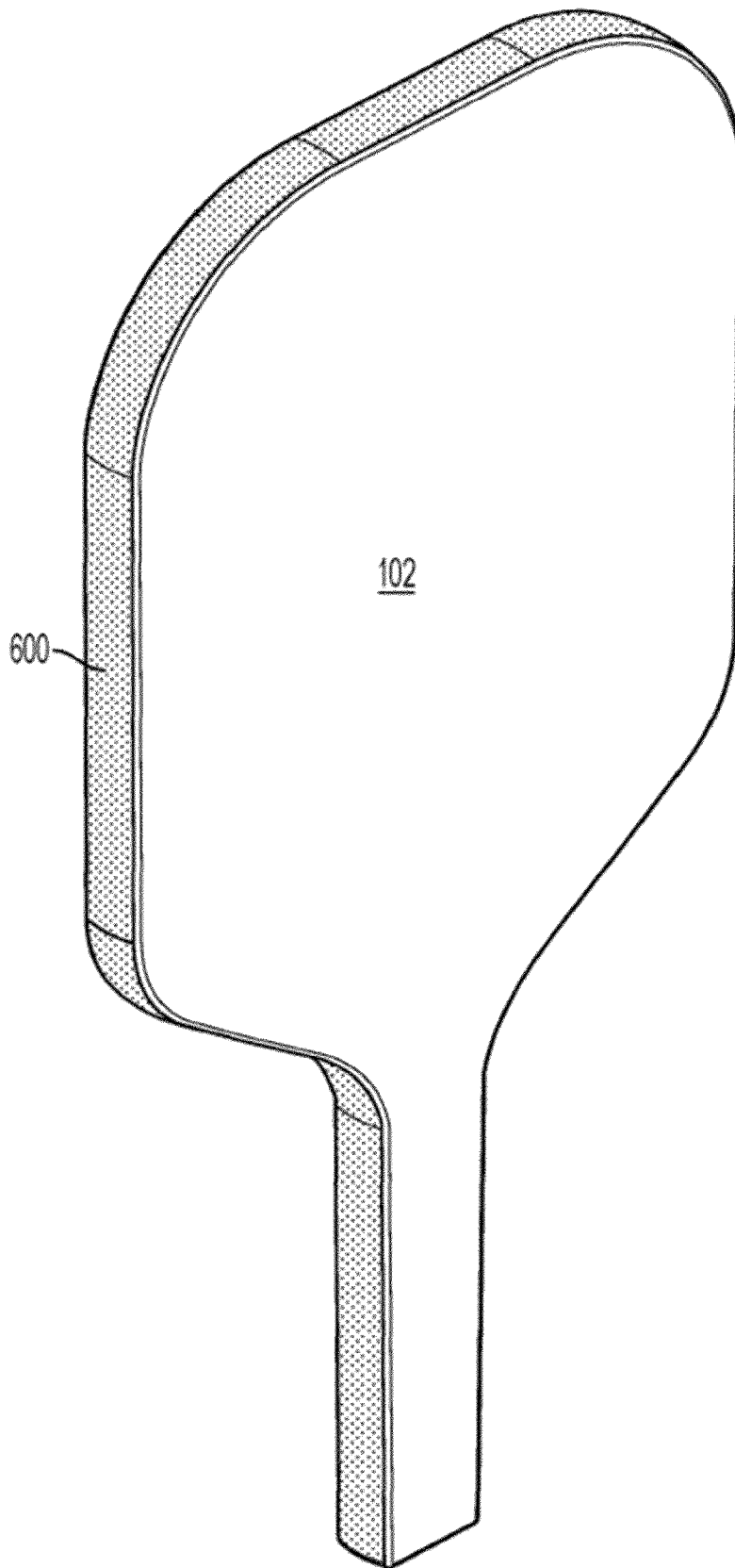

FIG. 7A

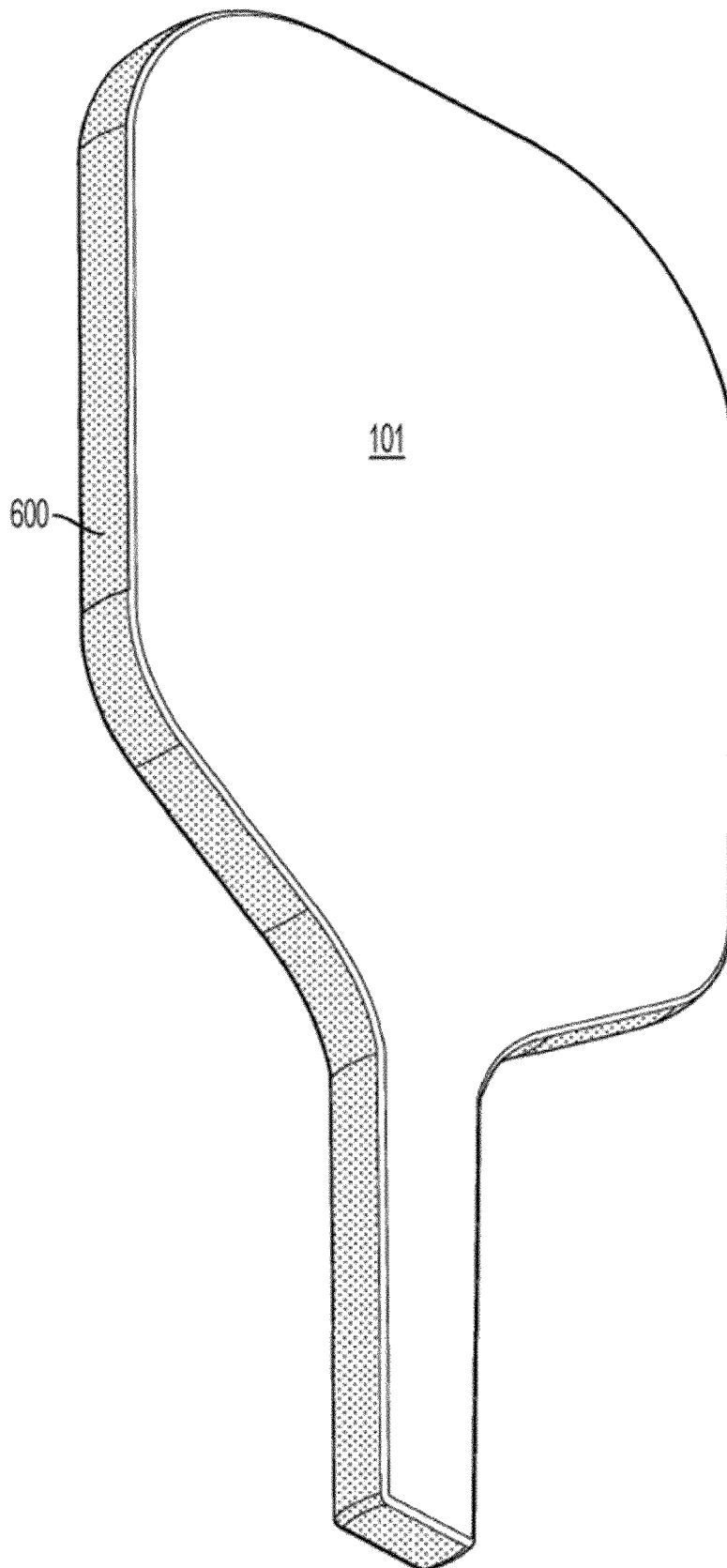

FIG. 7B

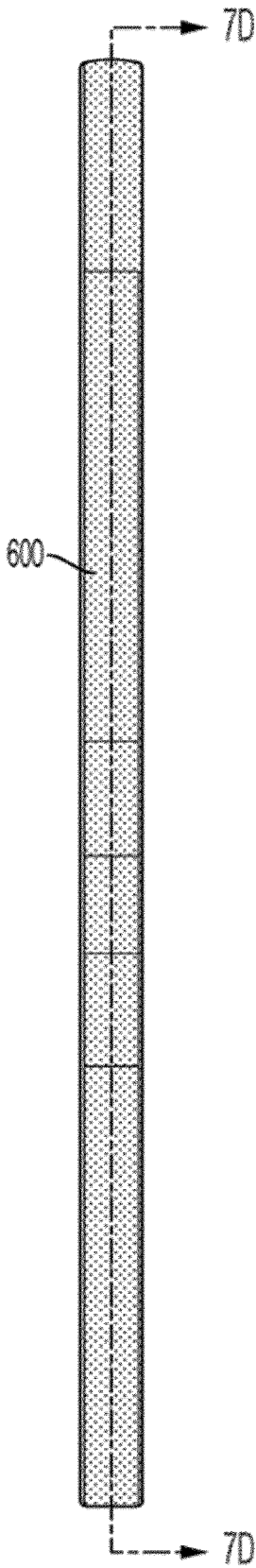

FIG. 7C

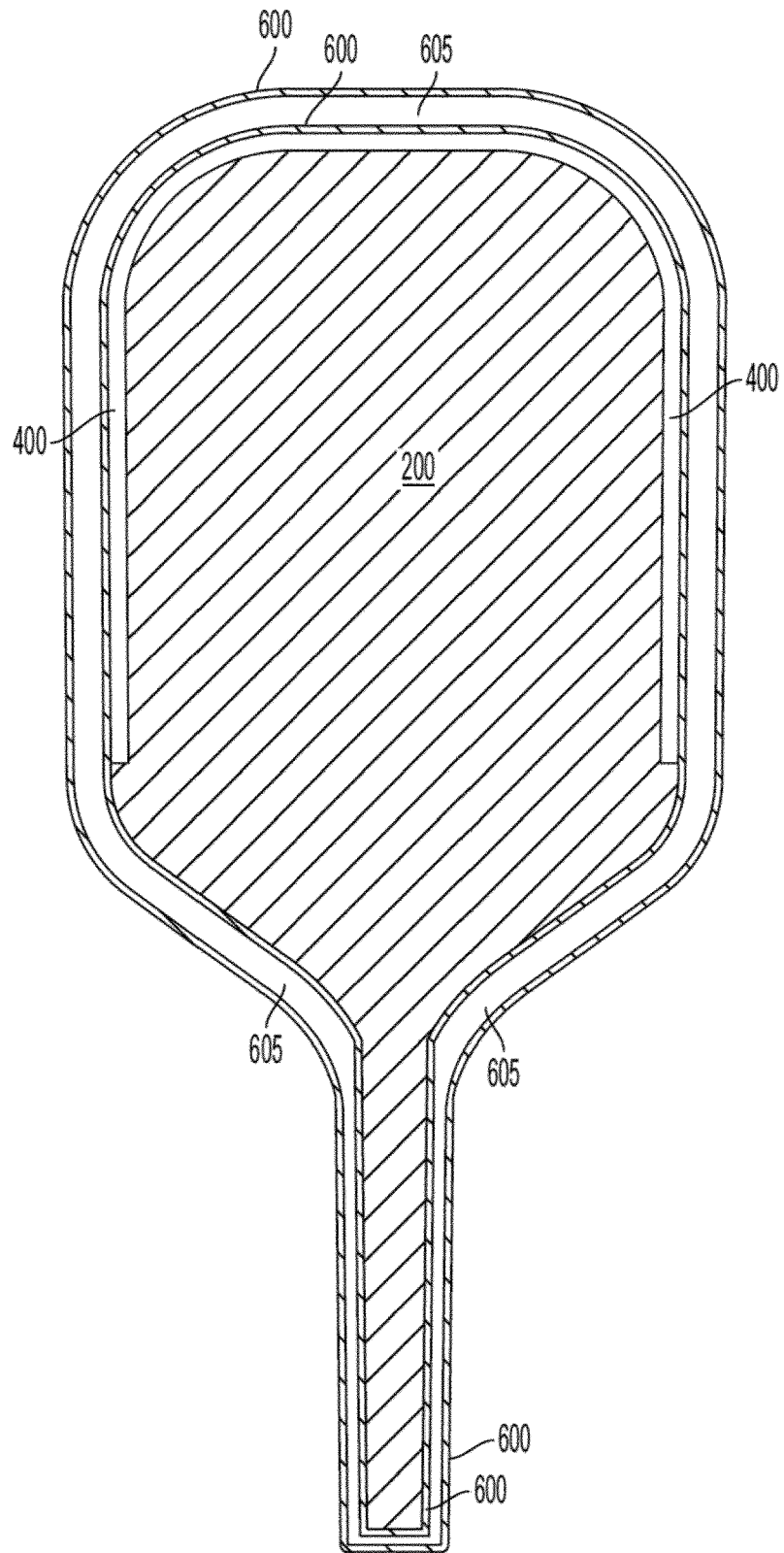

FIG. 7D

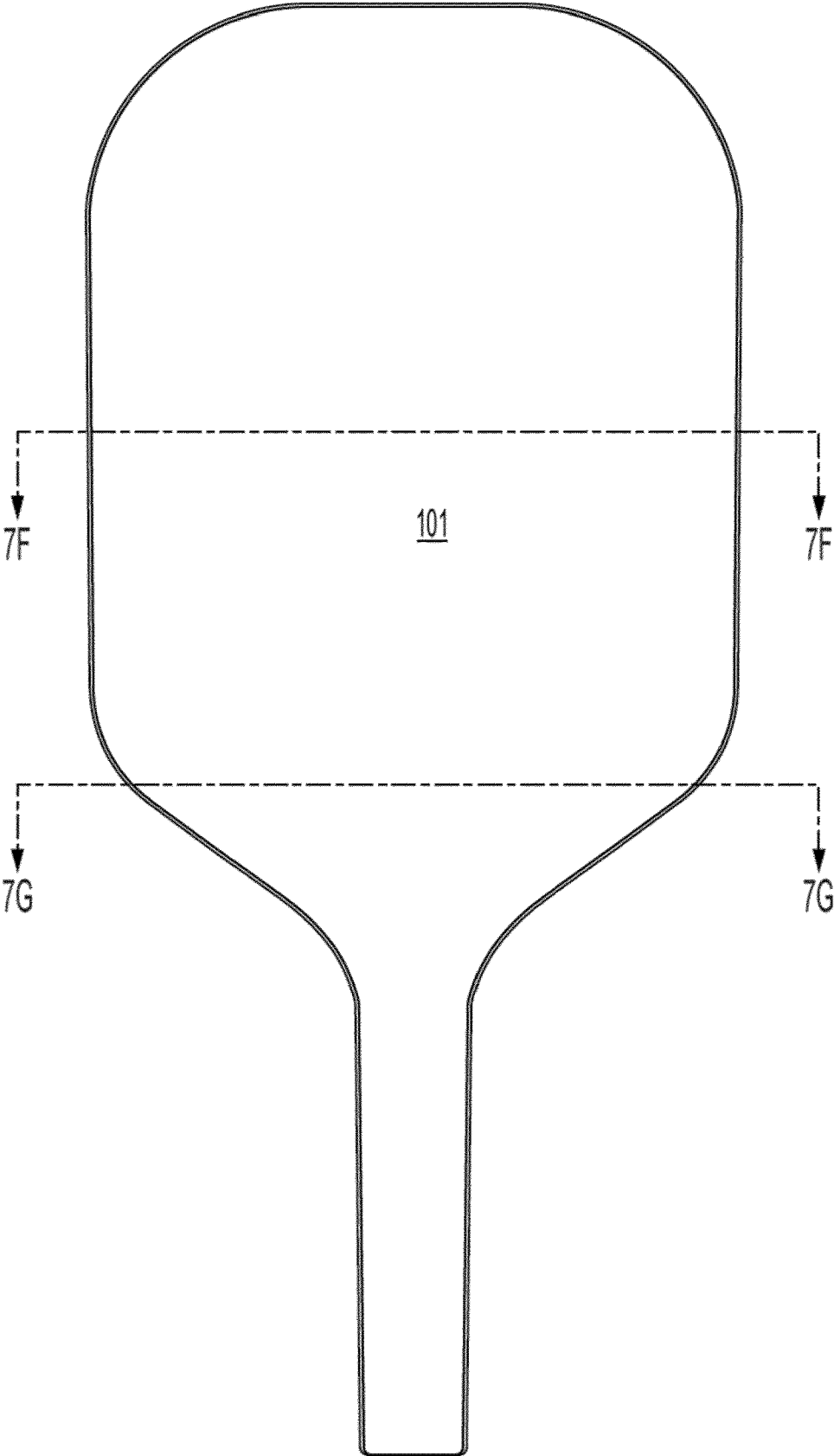

FIG. 7E

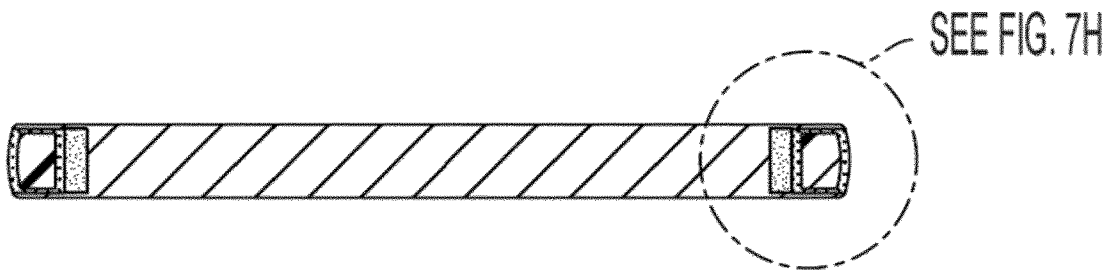

FIG. 7F

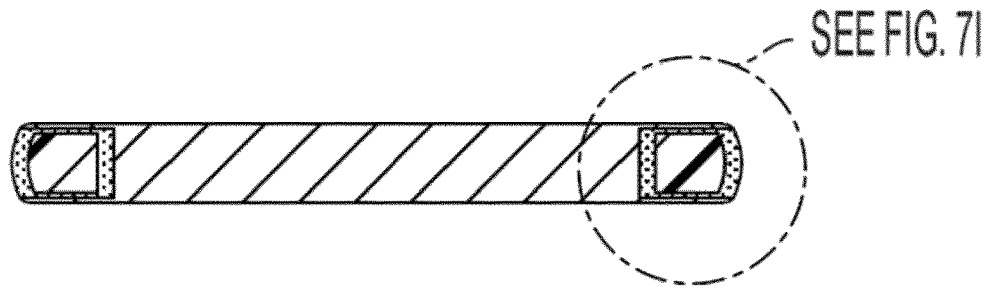

FIG. 7G

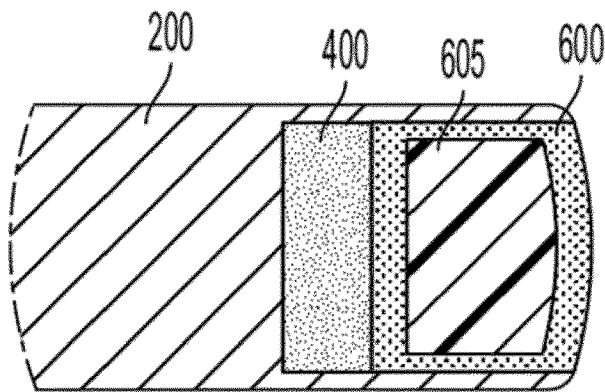

FIG. 7H

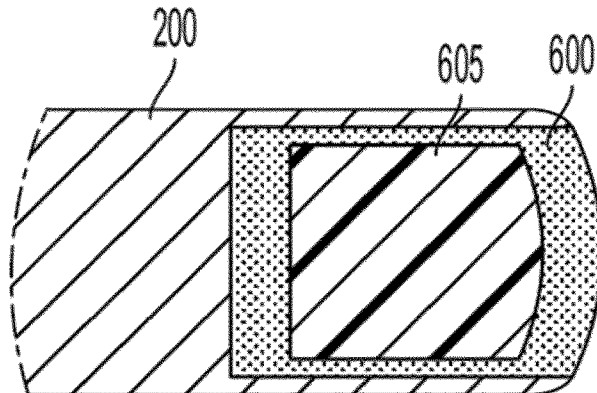

FIG. 7I

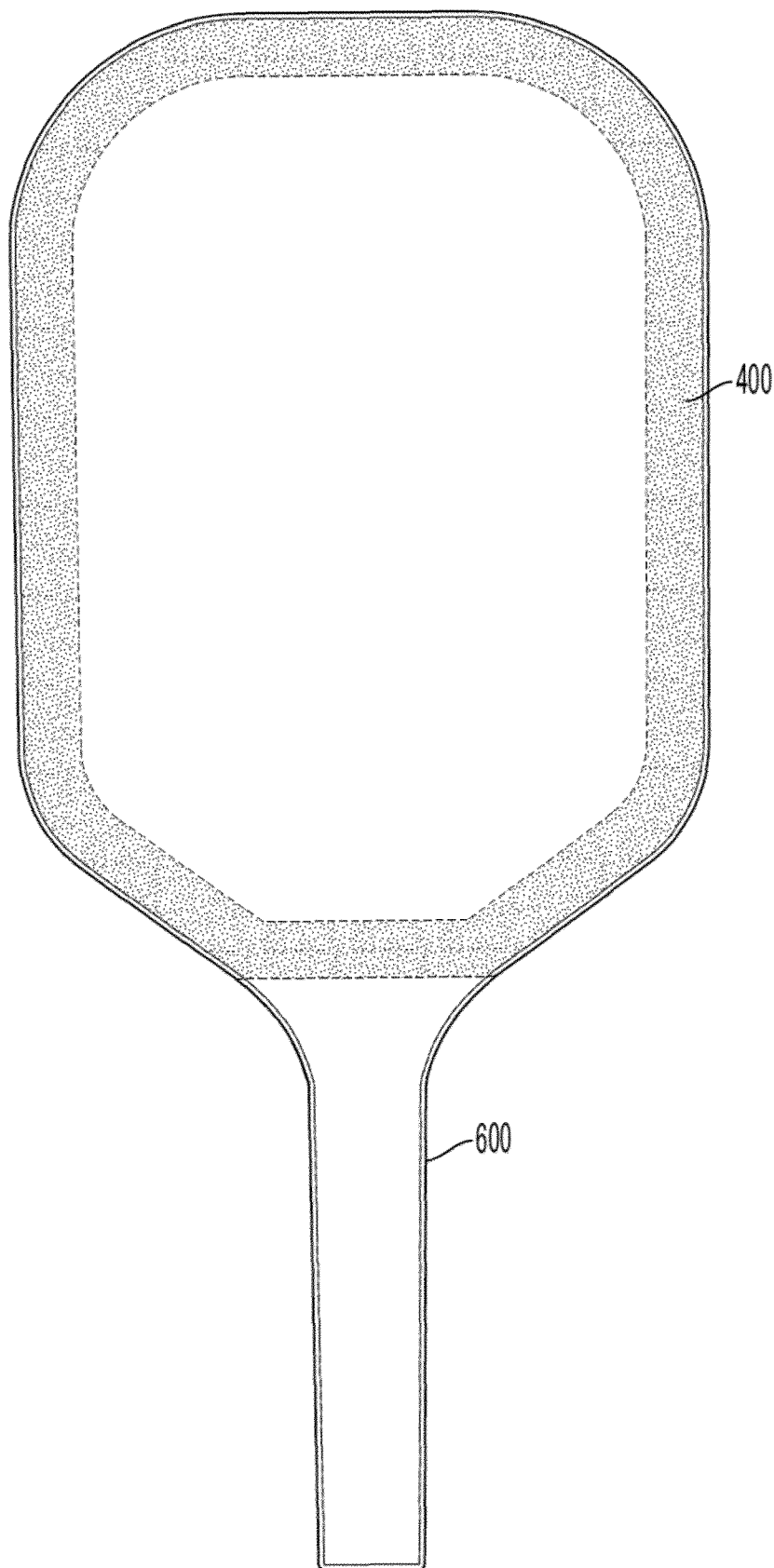

FIG. 8

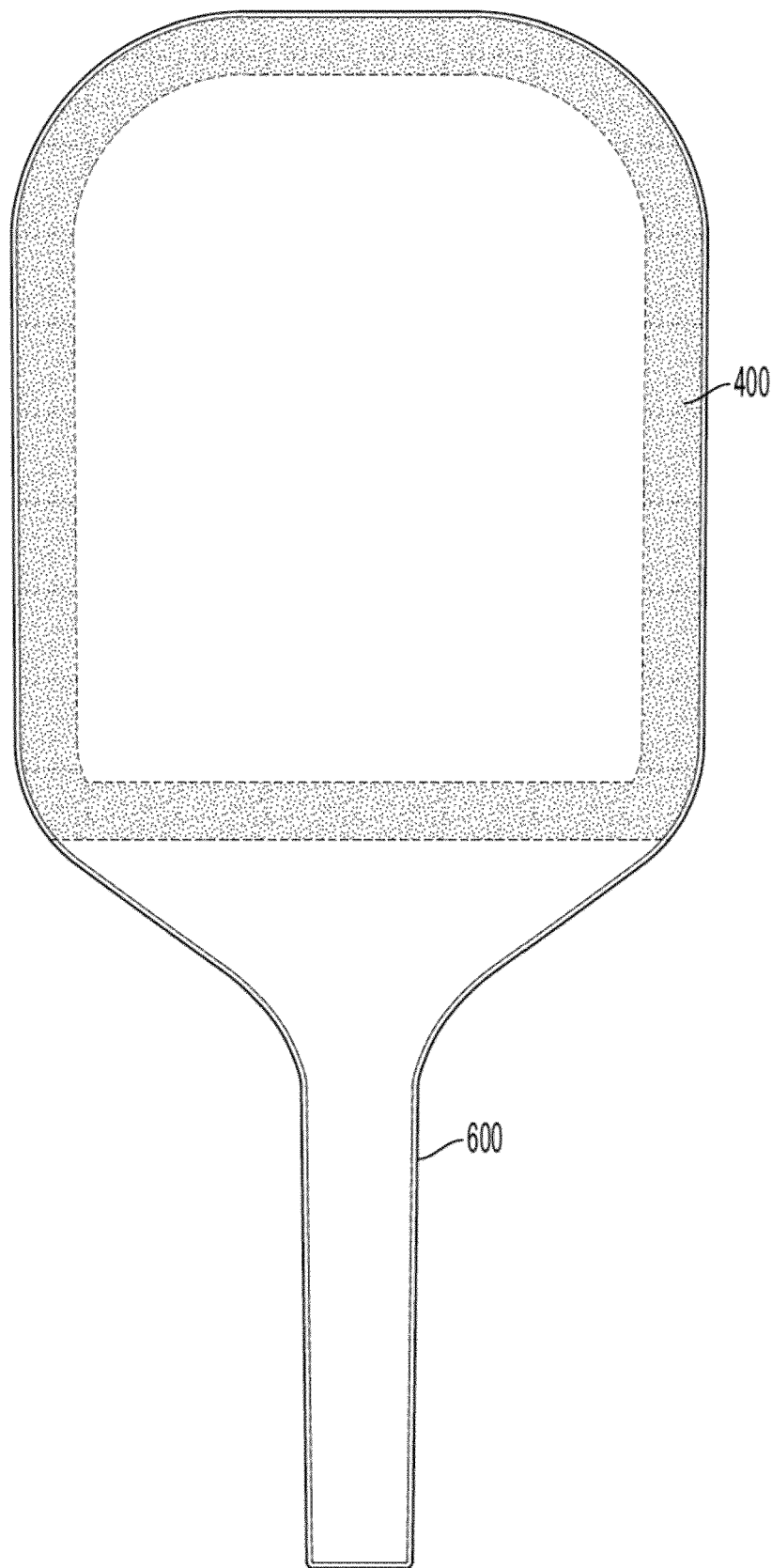

FIG. 9

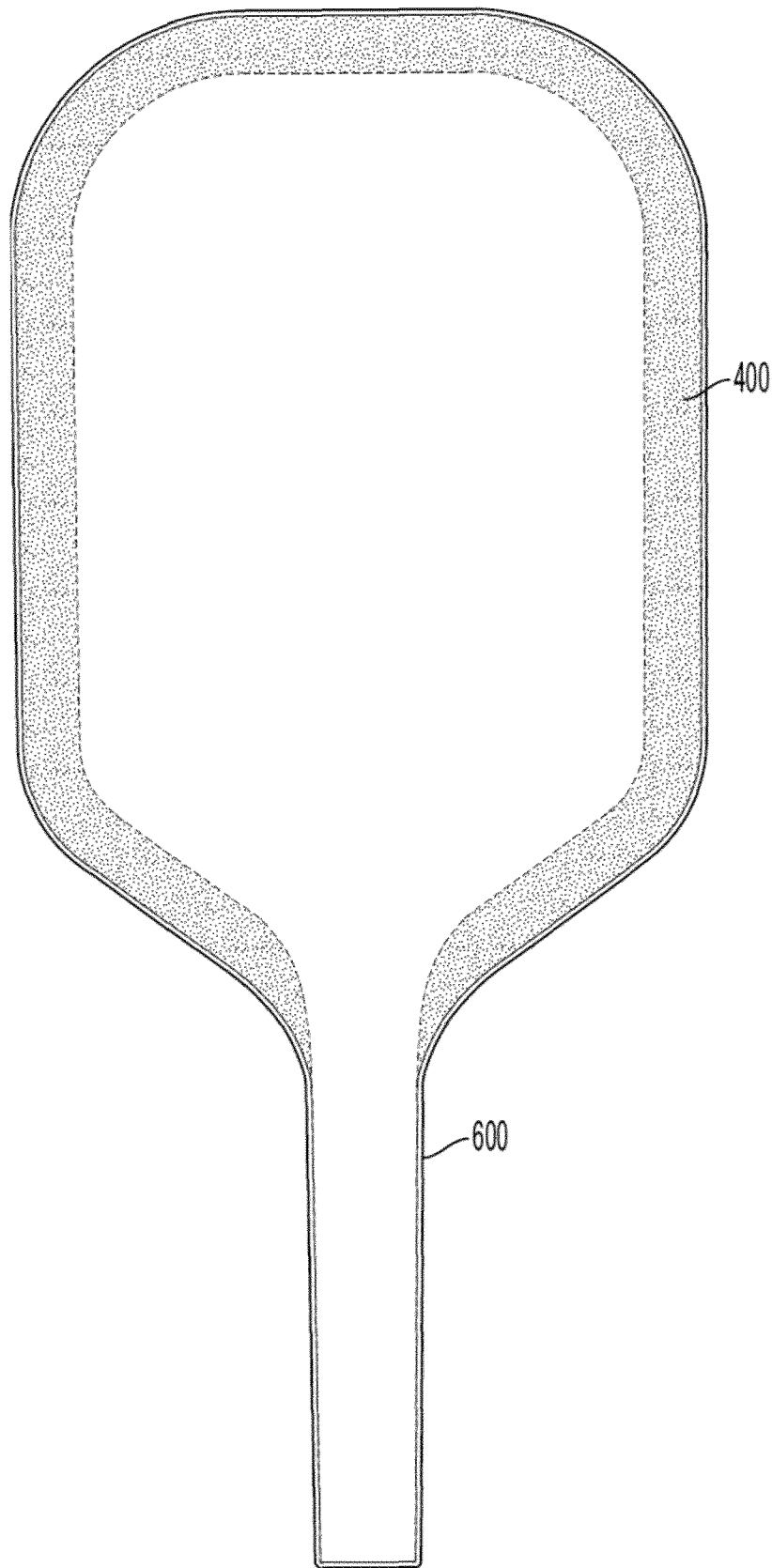

FIG. 10

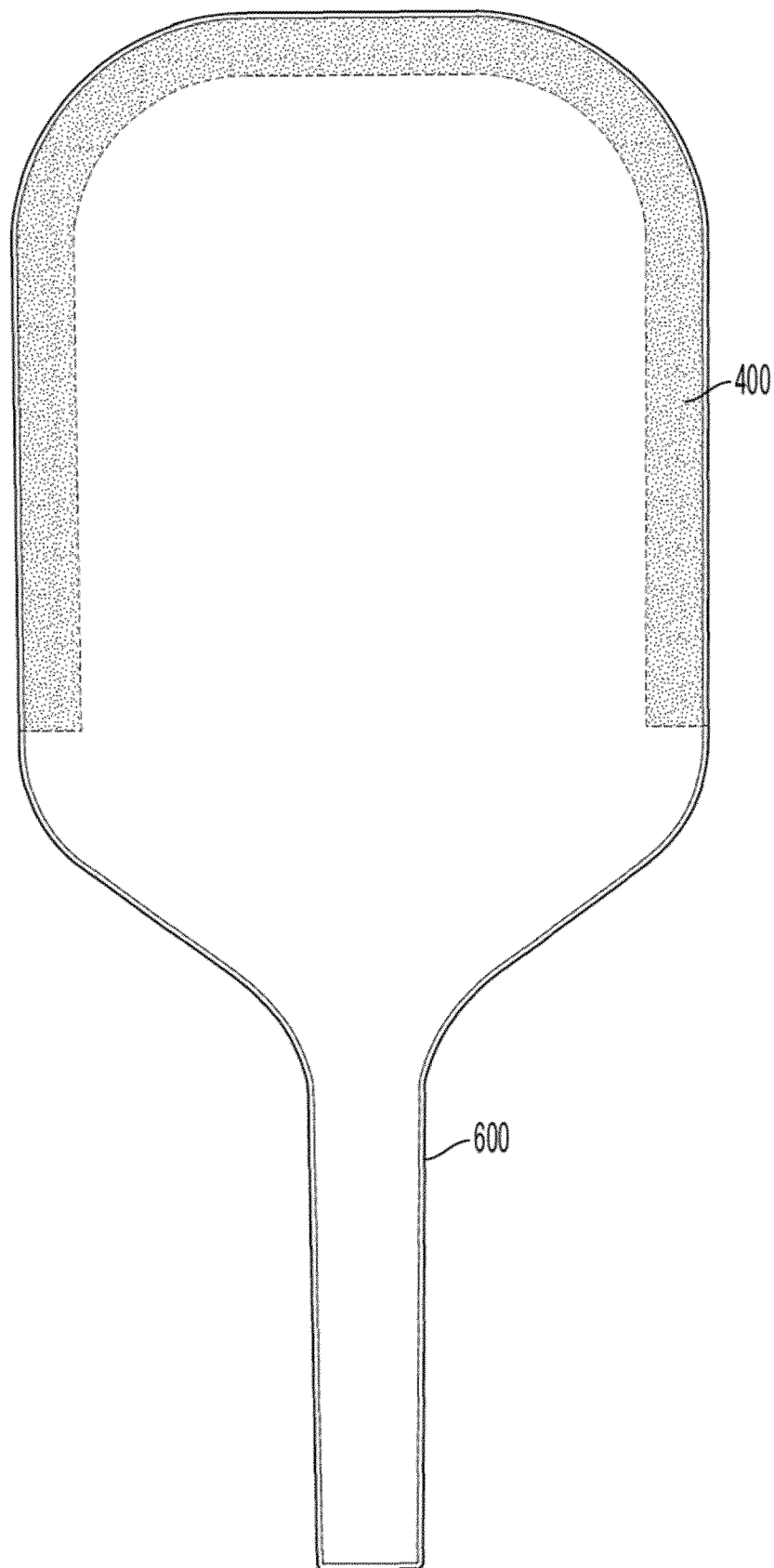

FIG. 11

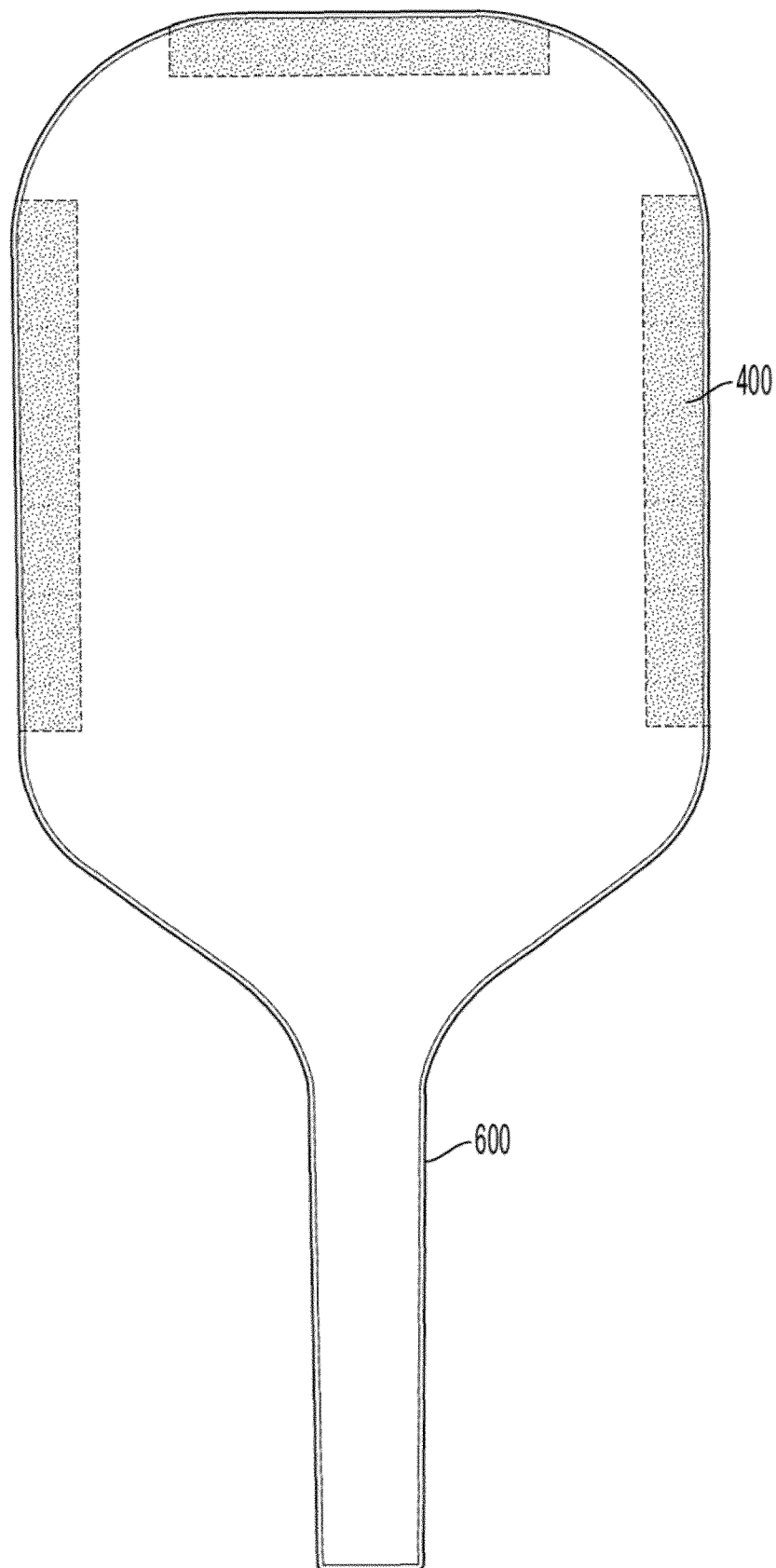

FIG. 12

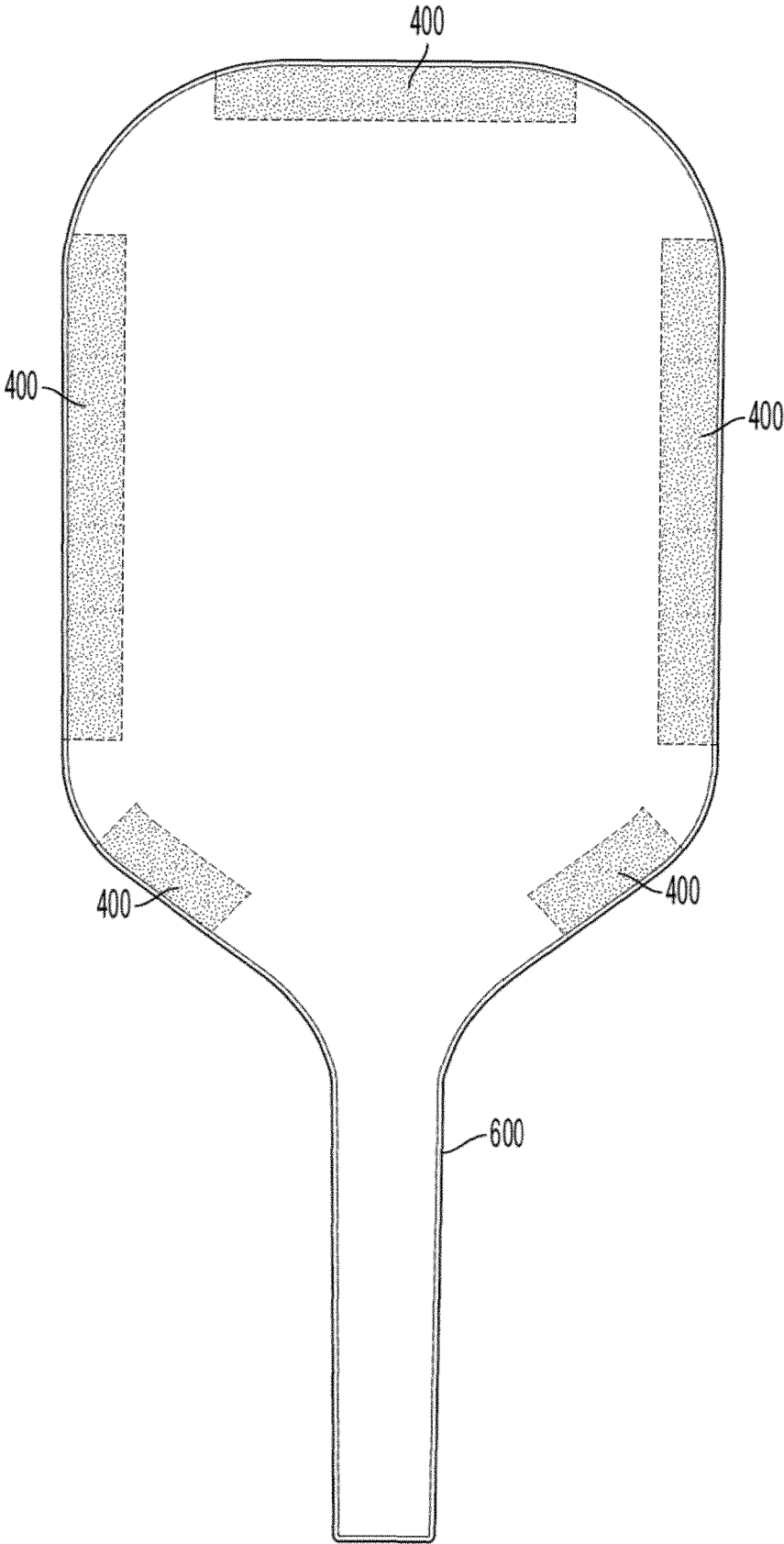

FIG. 13

U.S. Patent

Nov. 11, 2025

Sheet 18 of 31

US 12,465,826 B2

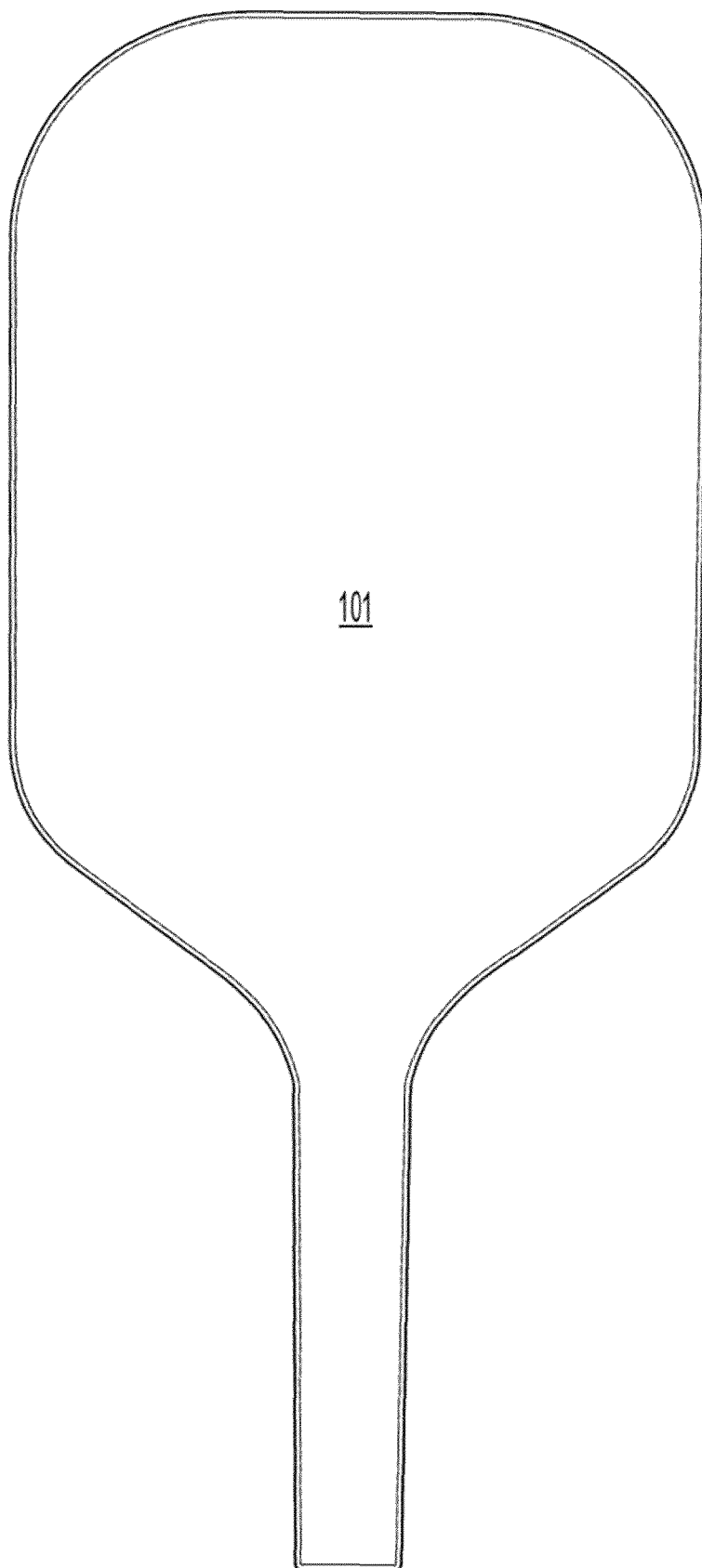

FIG. 14

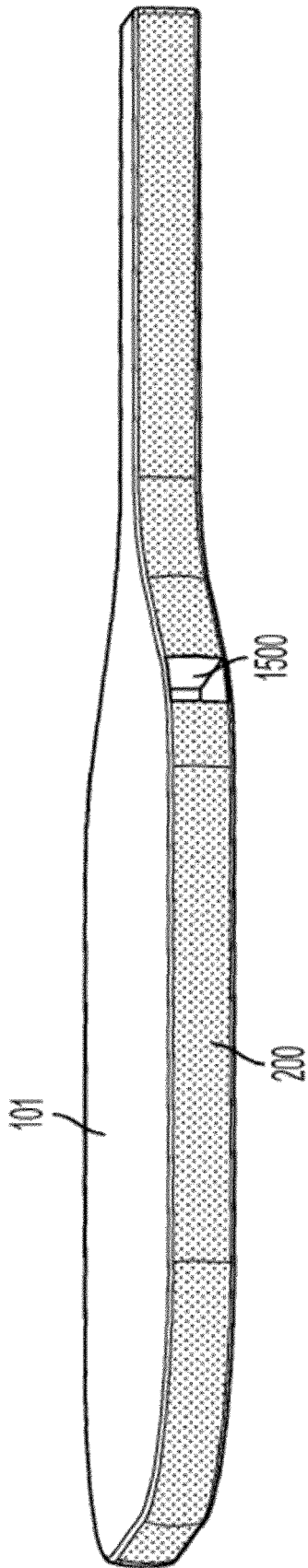

FIG. 15

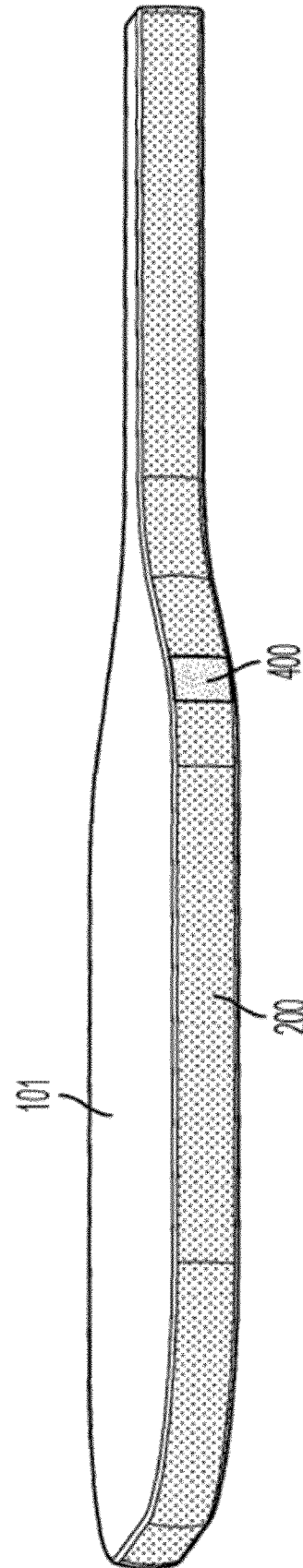

FIG. 16

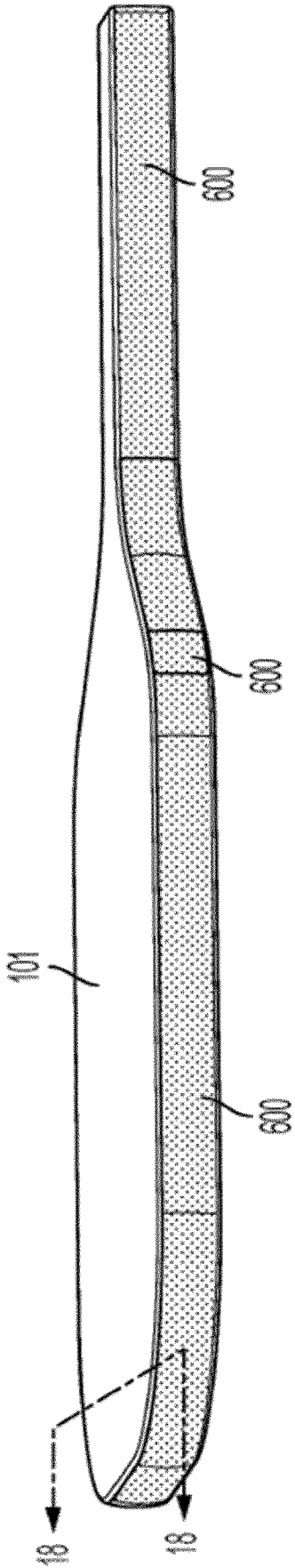

FIG. 17

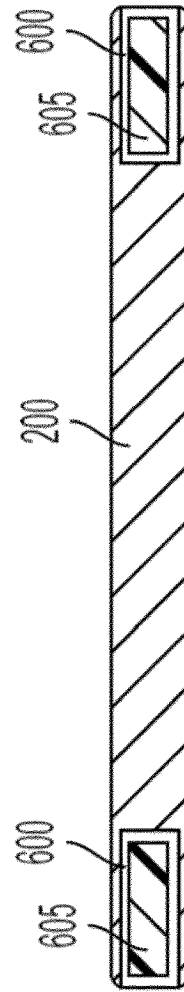

FIG. 18

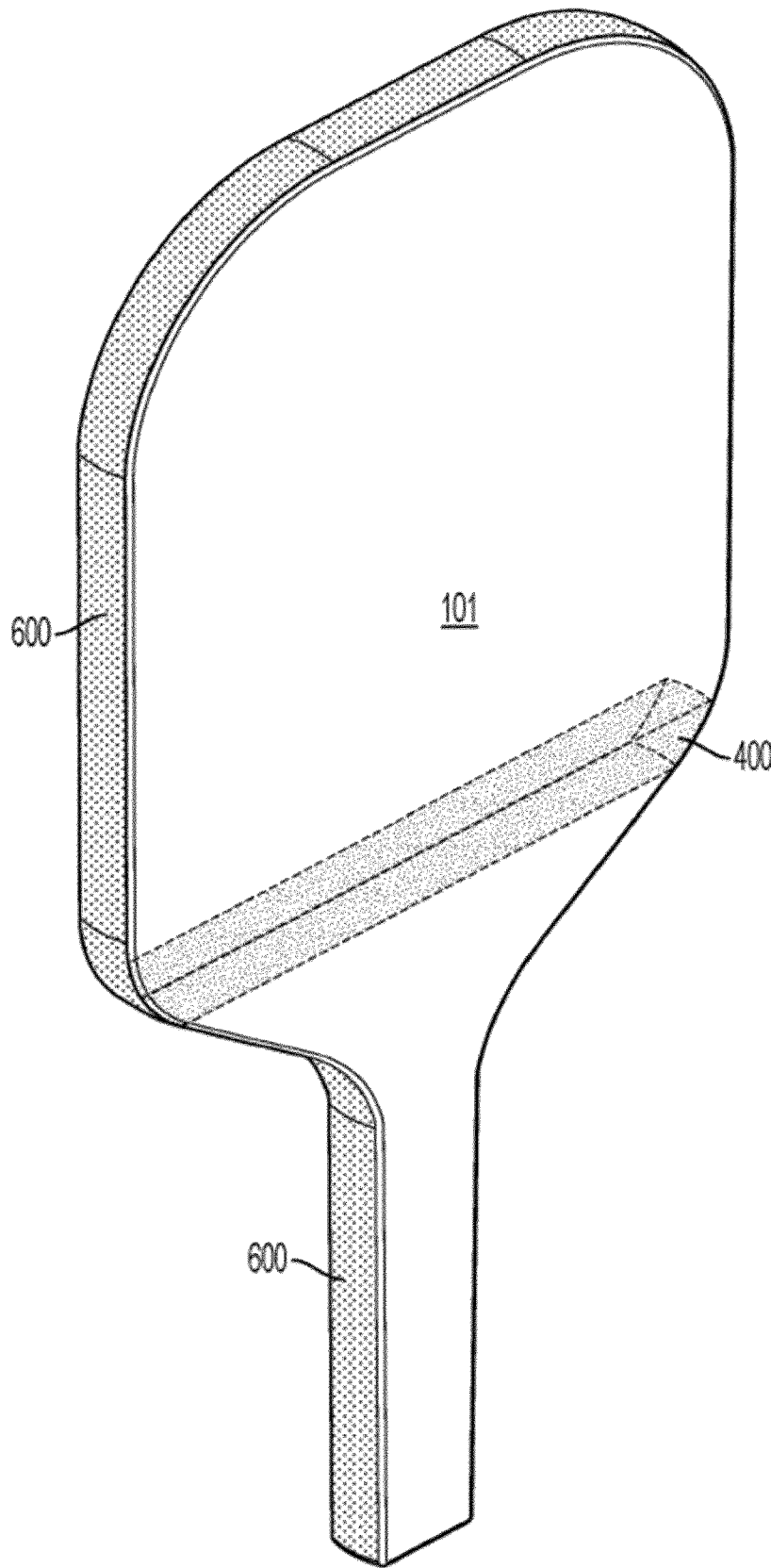

FIG. 19

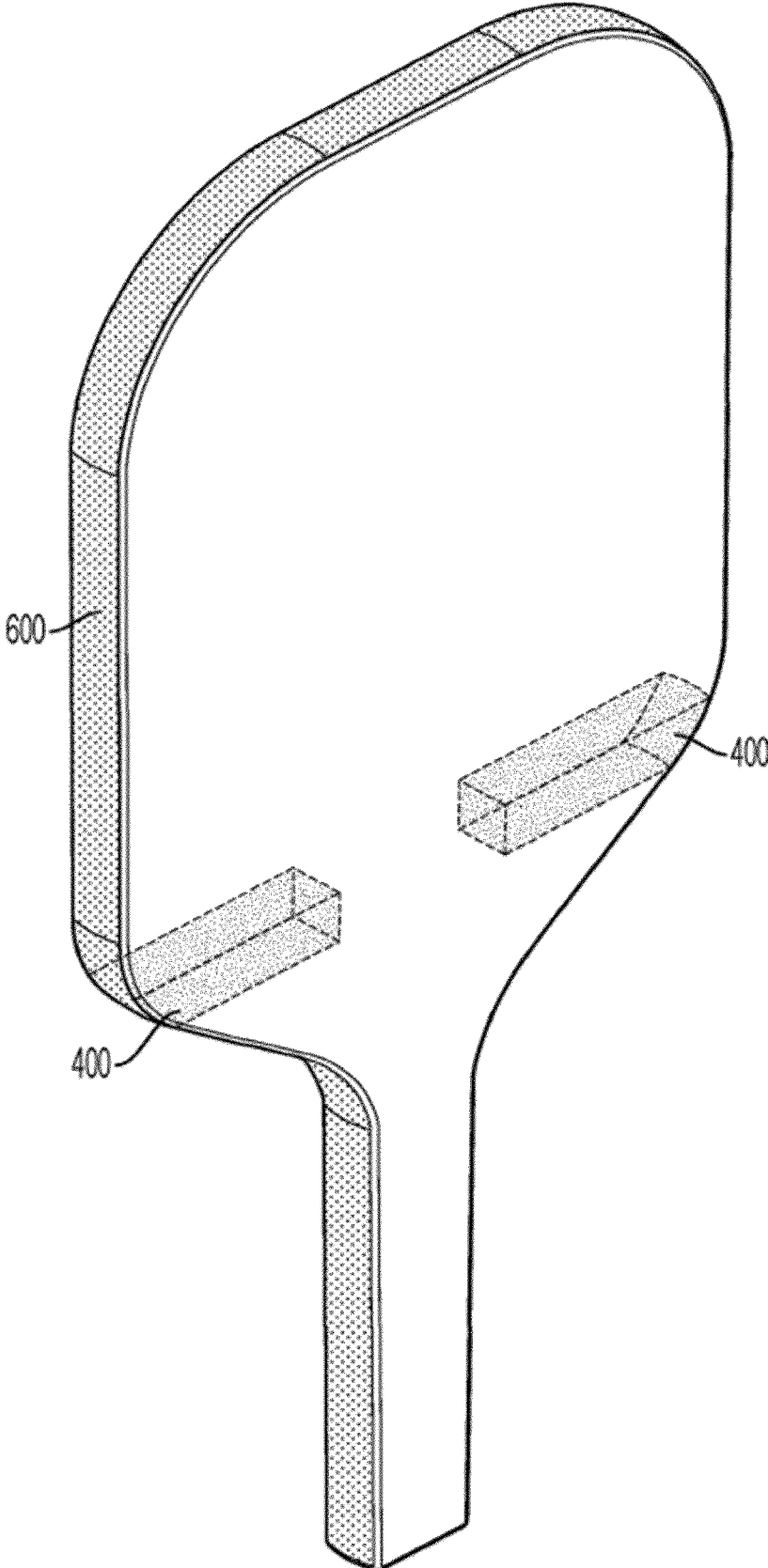

FIG. 20

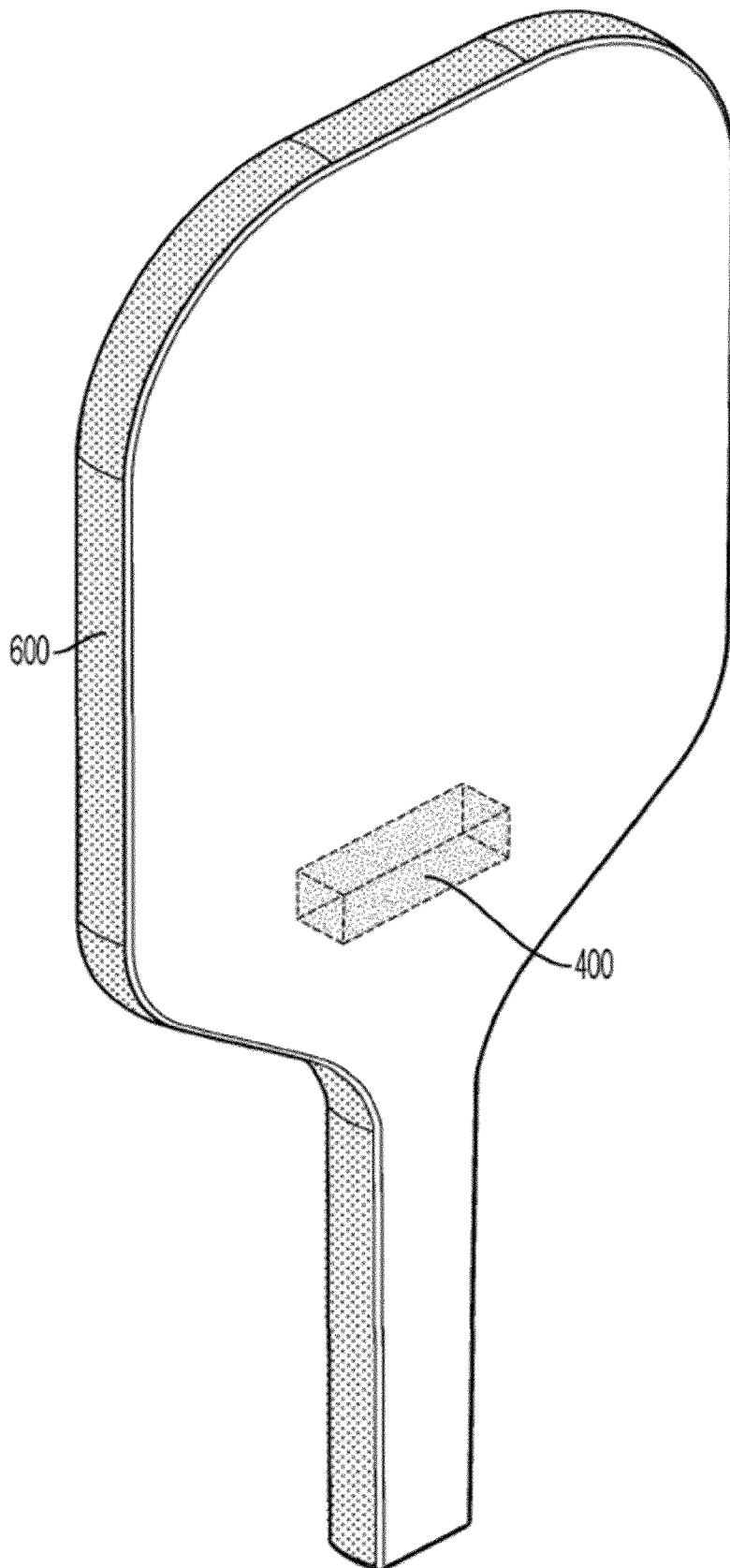

FIG. 21

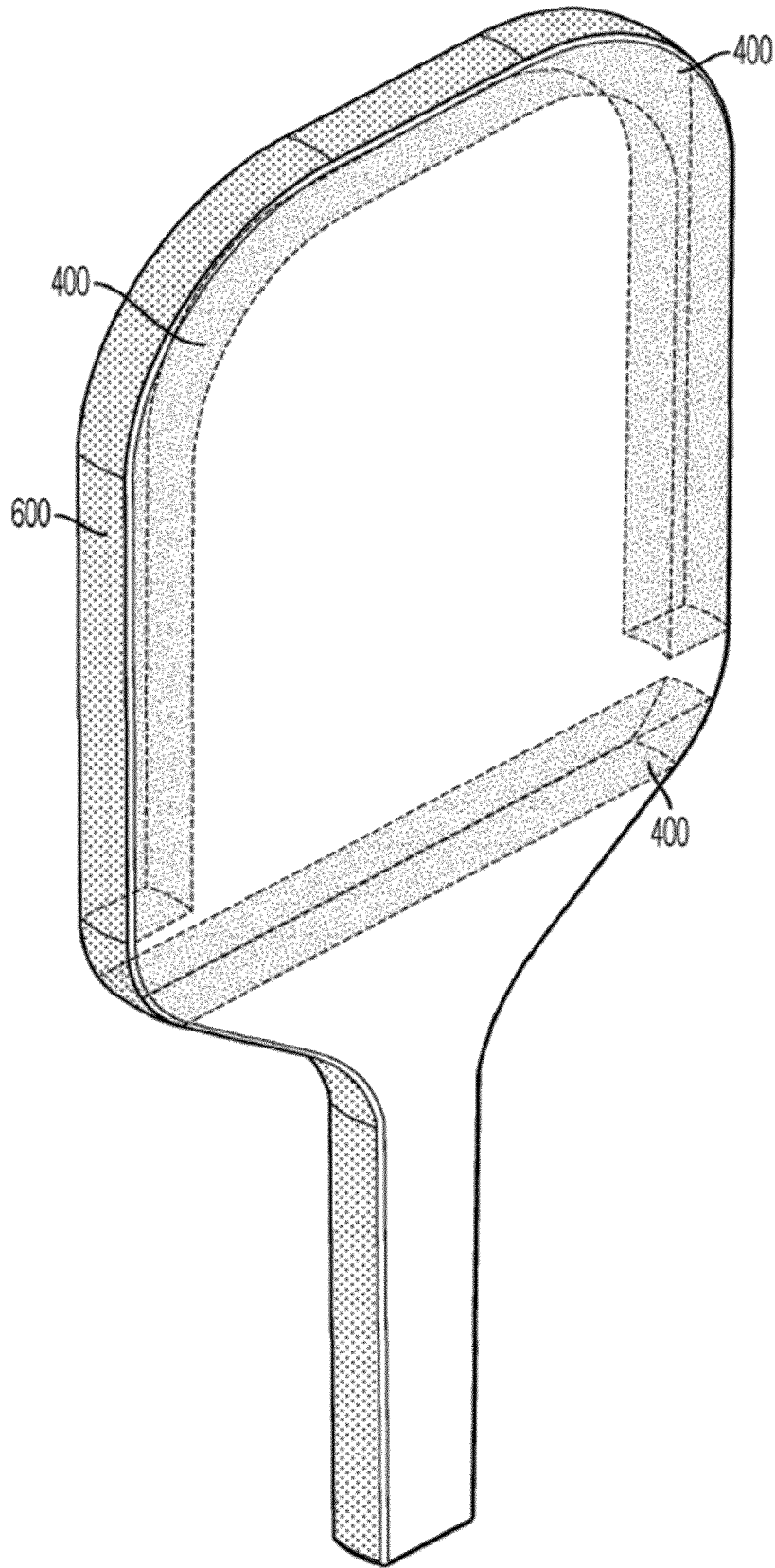

FIG. 22

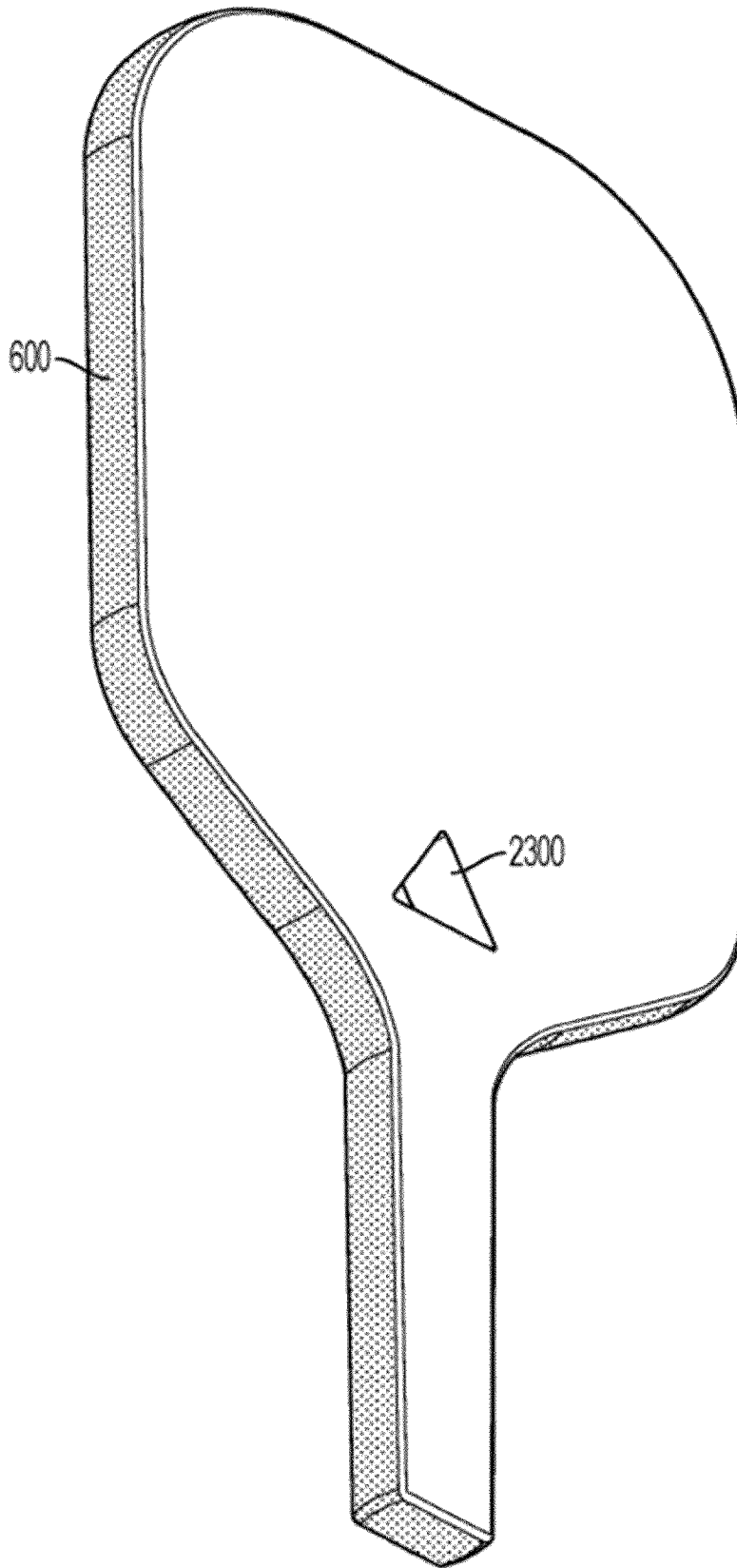

FIG. 23

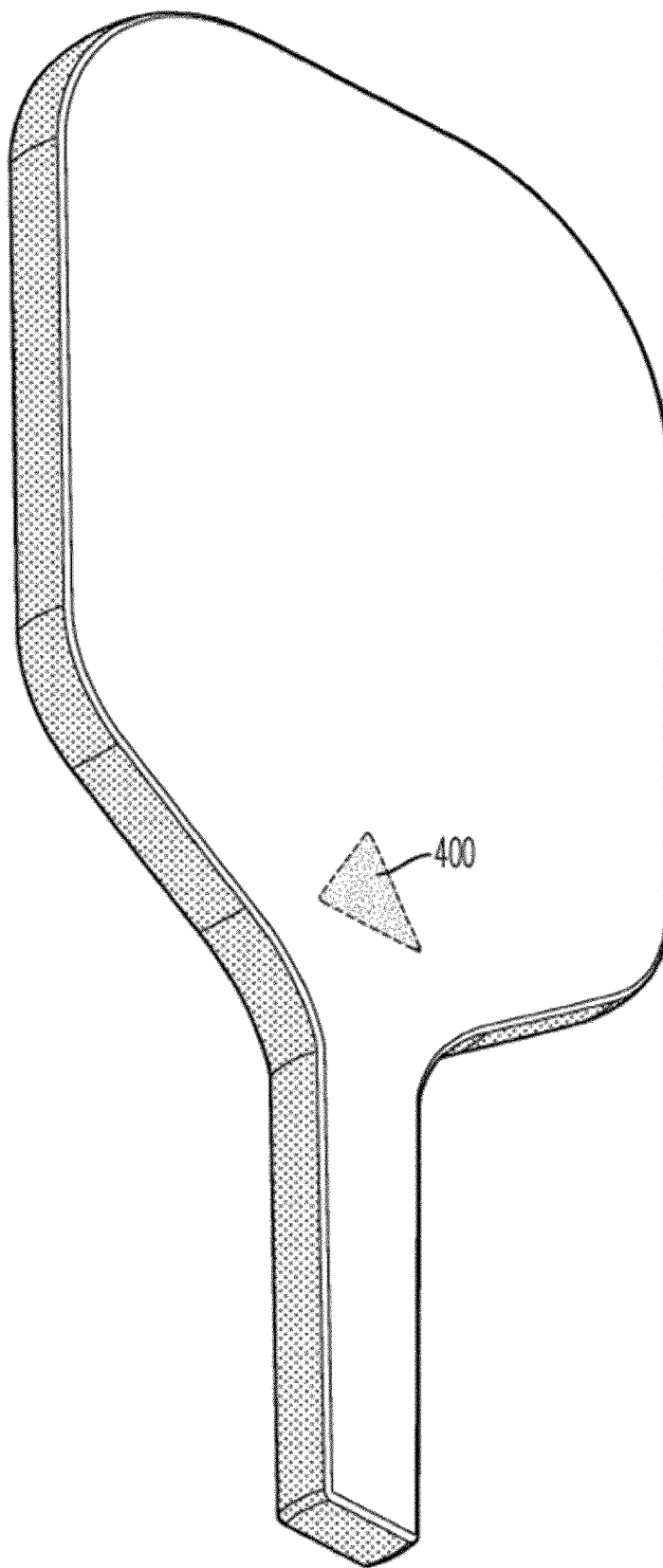

FIG. 24



FIG. 25

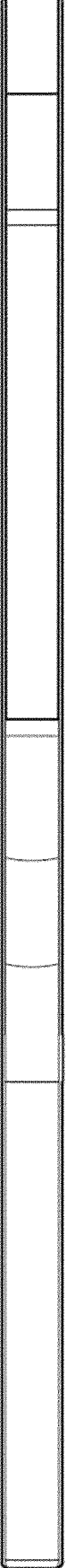

FIG. 26

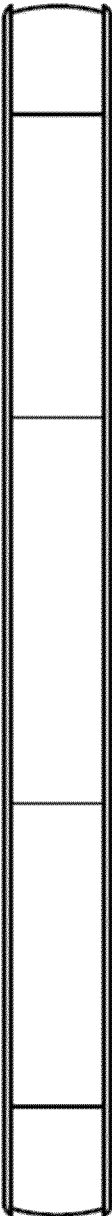

FIG. 27

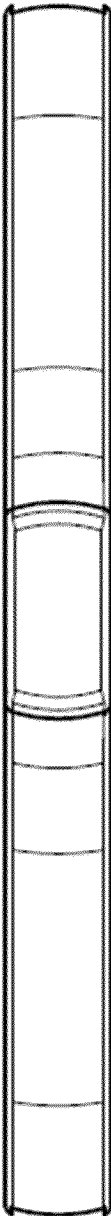

FIG. 28

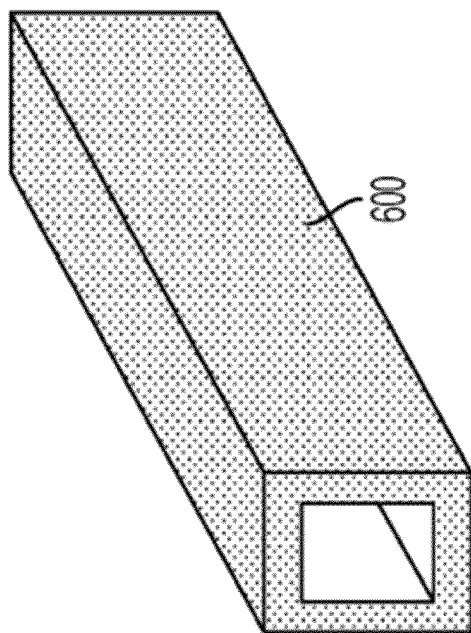

FIG. 29

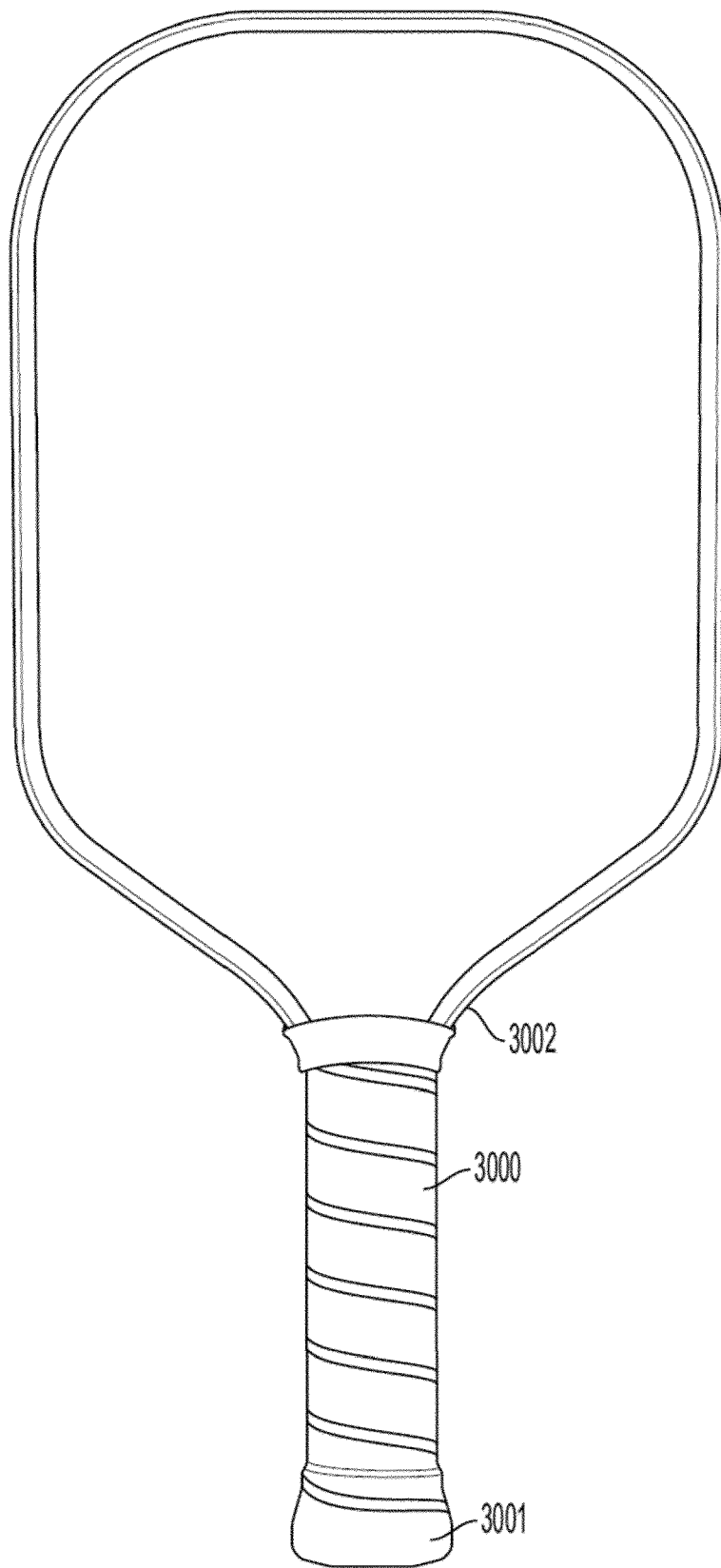

FIG. 30

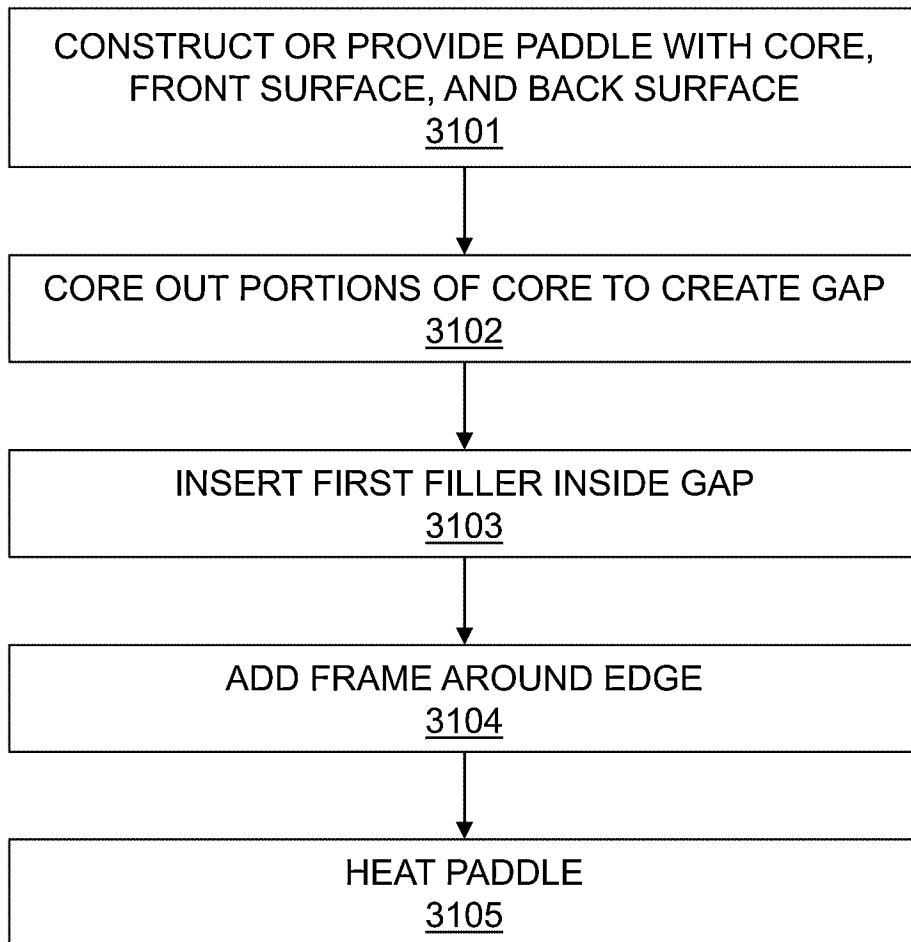

FIG. 31

US 12,465,826 B2

1

GAME PADDLE

CROSS-REFERENCE TO RELATED APPLICATIONS

This application is a continuation of U.S. patent application Ser. No. 18/389,174 filed on Nov. 13, 2023, which claims benefit to U.S. provisional application No. 63/535,565 filed on Aug. 30, 2023, and U.S. provisional application No. 63/543,865 filed on Oct. 12, 2023, where each of the foregoing is incorporated by reference herein in its entirety.

FIELD OF THE INVENTION

The present general inventive concept is directed to a paddle and a method for manufacturing the paddle.

DESCRIPTION OF RELATED ART

Paddles for paddle sports have been used for ages. A paddle typically refers to a paddle that is not comprised of strings (such as a tennis racket). Paddles are used to play games such as pickleball, paddleball, etc.

What is needed is paddles that can provide better performance for players.

SUMMARY OF THE INVENTION

It is an aspect of the present invention to provide an improved solid game paddle and method for its manufacture.

These together with other aspects and advantages which will be subsequently apparent, reside in the details of construction and operation as more fully hereinafter described and claimed, reference being had to the accompanying drawings forming a part hereof, wherein like numerals refer to like parts throughout.

BRIEF DESCRIPTION OF THE DRAWINGS

Further features and advantages of the present invention, as well as the structure and operation of various embodiments of the present invention, will become apparent and more readily appreciated from the following description of the preferred embodiments, taken in conjunction with the accompanying drawings of which:

FIG. 1A is a drawing showing a front view of a paddle, according to an embodiment;

FIG. 1B is a drawing showing a top perspective view of the paddle, according to an embodiment;

FIG. 1C is a drawing showing a back perspective view of the paddle, according to an embodiment;

FIG. 2 is a diagonal view showing the paddle after it is cored out, according to an embodiment;

FIG. 3 is a cross section of FIG. 2, according to an embodiment;

FIG. 4 is a diagonal view of the paddle with foam added, according to an embodiment;

FIG. 5 is a cross section of FIG. 4, according to an embodiment;

FIG. 6A is a diagonal view of the paddle with a frame added, according to an embodiment;

FIG. 6B is a cross section of FIG. 6A, according to an embodiment;

FIG. 7A shows a front view of the final paddle, according to an embodiment;

2

FIG. 7B shows a back view of the final paddle, according to an embodiment;

FIG. 7C shows a side view of the final paddle, according to an embodiment;

5 FIG. 7D shows a cross section shown in FIG. 7C, according to an embodiment;

FIG. 7E shows a front view of the final paddle, according to an embodiment;

10 FIG. 7F shows a cross section from the view shown in FIG. 7E, according to an embodiment;

FIG. 7G shows a cross section from the view shown in FIG. 7E, according to an embodiment;

15 FIG. 7H shows a detailed view of the view shown in FIG. 7F, according to an embodiment;

FIG. 7I shows a detailed view of the view shown in FIG. 7G, according to an embodiment;

FIGS. 8-13 are each drawings showing a front view of a paddle, according to various embodiments;

20 FIG. 14 is a front view showing another original paddle before it is cored out, according to an embodiment;

FIG. 15 is a perspective view showing a gap, according to an embodiment;

25 FIG. 16 is a perspective view showing first filler filling in the gap, according to an embodiment;

FIG. 17 is a perspective view showing a frame added to the edge of the paddle, according to an embodiment;

FIG. 18 is a cross section of FIG. 17 showing the core, first filler, and frame, according to an embodiment;

30 FIG. 19 is a perspective view showing a front of a paddle showing first filler on the inside, according to an embodiment;

35 FIG. 20 is a perspective view showing a front of a different paddle showing first filler on the inside, according to an embodiment;

FIG. 21 is a perspective view showing a front of another different paddle showing first filler on the inside, according to an embodiment;

40 FIG. 22 is a perspective view showing a front of another alternative paddle showing first filler on the inside, according to an embodiment;

FIG. 23 is a perspective view of a paddle with filler in the throat, according to an embodiment;

45 FIG. 24 is a perspective view of the final paddle, according to an embodiment;

FIG. 25 is a left side view of a final paddle, according to an embodiment;

FIG. 26 is a right side view of the final paddle, according to an embodiment;

50 FIG. 27 is a top view of the final paddle, according to an embodiment;

FIG. 28 is a bottom view of the final paddle, according to an embodiment;

55 FIG. 29 is a drawing showing a perspective view of the frame, according to an embodiment;

FIG. 30 is a drawing of a final paddle, according to an embodiment; and

FIG. 31 is a flowchart illustrating a method used to construct a paddle, according to an embodiment.

DESCRIPTION OF THE PREFERRED EMBODIMENTS

Reference will now be made in detail to the presently preferred embodiments of the invention, examples of which are illustrated in the accompanying drawings, wherein like reference numerals refer to like elements throughout.

US 12,465,826 B2

3

A paddle can be used to play games like pickleball, racquetball, paddleball, etc. The paddle is solid, meaning that it is not made of string with holes between the string (such as a tennis racket). The paddle can have some foam (or other filler) on the inside alongside other material(s) such as core, the filler can serve to increase power, soften feel and reduce vibration.

In an embodiment, the paddle can be made with a manufacturing process. The process can begin with using an original paddle. The paddle has a front and back surface and a core on the inside, in a "sandwich structure." The front and back surfaces can be made from any material, such as one, two three, four or more layers of unidirectional or weave of carbon, glass, or any natural or synthetic fiber and prepreg impregnated with any kind of resin. The core can be comprised of any open-cell structure or lattice (e.g., honeycomb) of polypropylene, aluminum, NOMEX, KEVLAR ARAMID, or any other synthetic or natural material.

The process then will core out (remove) a portion of the core. The portion of the core that is removed (gap) depends on the embodiment, as in different embodiments, different portions of the core can be cored out. The gap can be from 0.1 to 100 mm deep (from the edge to the center of the paddle). The process will then use a first filler (e.g., foam) to fill in the cored out portion (gap) of the core. In an embodiment, instead of the first filler the cored out portion (gap) can be left hollow.

The process will then insert a first filler (e.g., foam) into the gap. Note that the first filler can be a single material or a combination of at least two different materials. The process will then wrap a frame (such as a carbon frame) around the perimeter of the entire paddle. In an embodiment, the frame can be an airtight hollow cuboid structure and has a second filler (e.g., foam) inside the frame. Note that in an embodiment, the frame may not be airtight. The second filler can be made from a single material or a combination of at least two different materials. In alternate embodiment, the frame can simply be a solid material wrapped around the perimeter. The second filler can be the same material(s) as the first filler or it can be a different material(s). In an embodiment, the frame can also be hollow. Note that a frame aspect ratio is defined as the height of the frame divided by the width of the frame, and in an embodiment, the frame aspect ratio would be lower than a predefined number (e.g., 4).

FIG. 1A is a drawing showing a front view of an original paddle **100**, according to an embodiment. The front view and back view are identical. FIG. 1B is a drawing showing a top perspective view of the paddle, according to an embodiment. FIG. 1C is a drawing showing a back perspective view of the paddle, according to an embodiment. The paddle **100** is utilized to create the improved paddle as described herein. Note that any paddles described herein are not limited to any particular shape and any shape and/or thickness can be used. The front surface **101** and the back surface **102** can be made from any material, such as 1-4 or more layers of unidirectional or weave of carbon, glass, or any natural or synthetic fiber and prepreg, impregnated with any kind of resin are commonly used for the composite materials. Typically, the front surface **101** and the back surface **102** are made from the same material, although this is not required. A handle **105** is on the bottom of the paddle **100** and a head **110** is above the handle **105**. Example dimensions (in inches) for such a paddle can be, 15-17" (length)×9-7" (width), or 16.5"×7.5" or 16"×8". Grip length: 4-6", or 4.75-5.75". Grip circumference: 4-4.5", or 4-4.3", although these are just examples and any other dimensions can be used.

4

Note that the handle **105** can be defined as the bottom of the racket up unto the point where the curvature of the perimeter of the paddle (without a grip) starts to change (e.g., a straight line starts to curve). This point is shown in FIG. 1A by the dotted line 'H'. The face of the paddle can be considered the rest of the paddle, that is from the handle to the top of the paddle. The face can be broken up into two sections, the head **110** and the throat **103**. The head **110** is from the top of the paddle down to where the perimeter starts to curve (from a straight edge) which is shown in FIG. 1A by the dotted line T. The throat **103** is the region between the head and the handle. Thus, the face of the paddle comprises only the head **110** and the throat **103** but not the handle **105**. The height of the face is shown by the dotted line 'F' in FIG. 1A. All sections (e.g., head, throat, handle) are delineated by horizontal lines. These sections can be considered to extend throughout the thickness of the paddle.

An alternative method of determining the head and the throat sections is as follows. The height of the face is determined by measuring the distance from the top of the paddle to where the handle begins (which can be determined based on when the curvature becomes straight, or by the user of a different material for the handle, etc.) The bottom one third of this height (e.g., the bottom $\frac{1}{3}$ of the face) is the throat, and the top two thirds of this height (e.g., the top $\frac{2}{3}$ of the face) is the head. As an example of this method, assume the height of the face (shown as vertical line F) in FIG. 1A is 10 inches (from the top of the paddle to the top of the handle). The 10 inches does not include the handle. Then the throat cutoff line (shown as horizontal line T) is just at the lower $\frac{1}{3}$ of the face height, that is 3.33 inches over the top of the handle is the throat (or 6.66 inches below the top of the paddle). The region below the throat cutoff line and above the handle is the throat region. While FIG. 1A is drawn as 2-dimensional, the regions described herein extend into the thickness of the paddle.

FIG. 2 is a diagonal view showing the paddle after it is cored out, according to an embodiment. A core **200** is present between the front surface **101** and the back surface **102**. The core **200** can be comprised of any open-cell structure (or a plastic sheet closing the cells), lattice (e.g., honeycomb), or any other such structure, comprised of polypropylene, aluminum, NOMEX, KEVLAR or any other synthetic or natural material. "Coring out" comprises removing sections of the core **200** from the paddle **100**. This can be done by using a drill or other tool which creates a gap **202** where the core **200** previously existed. See operation **3102** and its accompanying description for more information on the coring out operation.

FIG. 3 is a cross section of FIG. 2, according to an embodiment. Between the top surface **101** and bottom surface **102** is the gap **202**. The gap **202** can be from 0.1 to 100 mm depth (from the edge to the center of the paddle), it can be continuous around all the paddle, or split in two, three, four or more sections of different lengths, depths, and shapes. The height of the gap can vary from 0.1 to 25 mm or to the max thickness of the core. The gap can be of any shape, concave, convex, U shape, or others.

FIG. 4 is a diagonal view of the paddle with foam added, according to an embodiment. A first filler **400** is added in the gap **202** although it does not completely fill the gap **202** as room is left for a frame (e.g., carbon frame). The first filler **400** can be EVA foam, polymer, thermoplastic, thermoset, thermoplastic elastomer, elastomer, rubber, foam, expandable material, or a mixture of any combination of these. The first filler **400** can be of any density, viscosity, and hardness.

US 12,465,826 B2

5

See operation **3103** and its accompanying description for more information on how the filler is applied.

The first filler **400** (and the gap **202** which it fills) can be of any cross-section shape, the height can vary from 0.1 to 25 mm or to the max thickness of the core, the width (distance from the frame wall to the core) can vary from 0.1 to 50 mm. The first filler **400** can be continuous around all the core or can be split in two, three, or more sections with same or different geometries, dimensions, and materials. The first filler **400** can surround the entire paddle, just the head, or just specific areas.

FIG. **5** is a cross section of FIG. **4**, according to an embodiment. Shown inside the gap **202** is the first filler **400**.

FIG. **6A** is a diagonal view of the paddle with a frame added (such as a carbon frame), according to an embodiment. A frame **600** is added around the edge of the paddle **100**. The frame **600** can be comprised of carbon, glass, or any synthetic or natural fiber with resin, plastic, rubber, metal, or any material that provides a rigid structure. The frame **600** can be of any cross-section shape, height, width, and length. It can be an entire piece or can be split into two, three, or more sections with same or different geometries and dimensions. The frame **600** can surround the entire paddle, just the head, just the handle, or just specific areas. See operation **3104** and its accompanying description for more information on how the frame is applied. An edge guard (not pictured) can be optionally used or not to cover the frame and a small area of the surfaces on both sides.

FIG. **6B** is a cross section of FIG. **6A**, according to an embodiment. The frame **600** is a hollow cuboid (or other) structure which houses a second filler **605**. The second filler **605** can be polymer, thermoplastic, thermoset, thermoplastic elastomer, elastomer, rubber, foam, expandable material, or a mixture of any combination of these. The second filler **605** can be of any density, viscosity, and hardness, and can be a single material or combination of different materials. The second filler **605** can be the same material as the first filler **400** or it can be a different material. In an embodiment, the second filler **605** can also be pressurized air (high pressure) since the frame **600** can be airtight or it can be hollow. Also shown is the core **200**. When the frame is a shell structure as shown, the frame wall can range from 0.01-10 mm, 0.1-10 mm, or 0.1-4 mm, or other ranges. Frame height: 1-20 mm or to the max thickness of the paddle. Frame width can be 1-30 mm, or 5-15 mm. The frame can also be a solid structure (not shell structure), in this case the examples of dimensions would be the same, but there's no wall thickness in this case.

FIG. **7A** shows a front view of the paddle with the frame installed, according to an embodiment. FIG. **7B** shows a back view of the paddle with the frame installed, according to an embodiment. The paddle shown in FIGS. **7A** and **7B** is the final paddle after the manufacturing process is complete. The first filler **400** and the second filler **605** are not visible to the user because they are internal to the paddle. However, the first filler **400** and the second filler **605** are inside the paddle and hence the user cannot see them and may not even know the first filler **400** and the second filler **605** are present inside the paddle. With any of the embodiments described herein, the final paddle will appear like FIGS. **7A** and FIG. **7B** because the internal structure (e.g., core, first filler, second filler, etc.) would not be visible.

FIG. **7C** shows a side view of the final paddle, according to an embodiment. FIG. **7D** shows a cross section shown in FIG. **7C**, according to an embodiment. Shown is the frame **600** with the second filler **605** inside the frame **600**. The first

6

filler **400** is present inside the core **200** which fills the gap **202** previously made in the core **200**.

FIG. **7E** shows a front view of the final paddle, according to an embodiment. The back view of the final paddle is identical to the front view. Note that the frame surrounds the entire final paddle. In an embodiment, the frame does not surround the entire paddle but only a portion of it, for example, the frame can only surround a part of the head of the paddle, or just part of the handle, etc., FIG. **7F** shows a cross section from the view shown in FIG. **7E**, according to an embodiment. FIG. **7G** shows a cross section from the view shown in FIG. **7E**, according to an embodiment. Note that in FIG. **7G** there is no first filler **400** (as shown in FIG. **7F**) because the portion of the paddle shown in FIG. **7G** was not cored out and hence no first filler **400** was applied to that region. FIG. **7H** shows a detailed view of the view shown in FIG. **7F**, according to an embodiment. Note that FIG. **7H** shows a height and width measurement of the frame. The frame aspect ratio is the height/width. In one embodiment, the frame aspect ratio should be smaller than 4 (or smaller than equal to 4). In another embodiment, the frame aspect ratio should be smaller than 6, or smaller than 4, or smaller than 2, or other numbers. FIG. **7I** shows a detailed view of the view shown in FIG. **7G**, according to an embodiment.

FIGS. **8-13** are each drawings showing a front view of a paddle, according to various embodiments. Note that the back view of each paddle would be identical to the respective front view. All other structures not shown would be the same as described herein. In each of these figures, the first filler is shown which is inside the respective paddle and would not be visible to the user. Before the first filler is added, as described herein, the section where the first filler is shown was cored out (the gap). All of these embodiments also have the frame (with the second filler inside the frame) applied around the entire edge as described herein. Thus, all of the embodiments shown in FIG. **8-13** can be constructed using the process described herein, and can have the same general structure as shown in FIGS. **2-7I** but for the different location and shape of the gap which was cored out of the original paddle and filled with the first filler. Note that other configurations of core and first filler can be used as well, and these are just examples. Note that in FIGS. **8-13**, the first filler and the second filler are both not visible to the user as they are both embedded inside the paddle (the first filler being inside the game and the second filler being inside the frame). The paddles shown in FIGS. **8-13** would appear as shown in FIGS. **7A**, **7B** because any internal structures (first filler **400**, second filler second filler **605**, core **200**, etc.) would not be visible as it would be covered by the front and back surfaces and possibly the frame **600**.

In the embodiment shown in FIGS. **7D** and **8-13**, the gap and filler used to fill the gap were near the perimeter of the head (the head being opposite of the handle) of the paddle. In a further embodiment, the gap and filler used to fill the gap can be in other locations in the paddle (not just near the perimeter), although typically closer to the handle than the head. FIGS. **14-18** illustrate the method of constructing a paddle where the gap and filler used to fill the gap are present in various locations inside the paddle. Note that the construction process can be the same as shown with respect to FIGS. **1-13**.

FIG. **14** is a front view showing another original paddle before it is cored out, according to an embodiment. FIGS. **15-19** show a process of how a dampener is applied to this original paddle. Note that the core is present throughout the another original paddle (as shown in other figures) and is surrounded by a front and back surface. The outer surfaces

US 12,465,826 B2

7

can be comprised of one, two, three, four or more layers of unidirectional or weave of carbon, glass, or any natural or synthetic fiber and prepreg, impregnated with any kind of resin. The core 200 can be comprised of a honeycomb structure of polypropylene, aluminum, Nomex, Kevlar or any other synthetic or natural material. The core is not limited to a honeycomb structure. The core can form the entire paddle (head and handle) or the head only. The core can be surrounded by an edge guard, or any type of frame, or edgeless.

FIG. 15 is a perspective view showing the paddle from FIG. 14 after it was cored out, according to an embodiment. Note that a gap 1500 in the core 1400 is where the core 1400 was drilled (or other process) to form the gap 1500. Note that the gap 1500 is near the handle 1501. FIG. 16 is a perspective view showing a first filler filling in the gap (as described herein), according to an embodiment. The gap 1500 (and hence the first filler) extends throughout the entire original paddle. Note that the gap 1500 extends throughout the paddle and out through the opposite side of the paddle. While the gap 1500 extends throughout the paddle, the paddle does not collapse into two sections because the front and back surface keep the paddle together until the first filler is inserted to fill the gap 1500. Because the gap is typically smaller than the total thickness of the paddle, leaving some part of the original core, which also helps the paddle to not collapse. FIG. 19 shows the first filler 1600 extending throughout the original paddle.

The gap 1500 is used to place the vibration dampener (first filler) but can also be hollow partially or completely. The gap can be of any dimension, cross section shape and any position, it can be continuous across all the paddle, or split into two, three, four or more sections of different lengths, widths, and shapes. It can be linear or curved, in the center of the paddle or in the edges. The gap can be inside the sandwich structure or also reach/pass the front and back surfaces. It can be on the head (edges, center, top, bottom), neck, or handle of the paddle. Multiple gaps can be used simultaneously in the same or different parts of the paddle. If the gap is located in the edges of the paddle, it can be exposed to the outside (on both edges of the paddle), or can be covered with a frame, edge guard or any other material or structure.

The gap 1500 is then filled with a first filler 1600. The first filler can be a foam, polymeric foam, solid, liquid, gel of any type of polymer, thermoplastic, thermoset, thermoplastic elastomer, elastomer, rubber, expandable material, and any other material or a mixture of them. The first filler can feel completely or partially the gap 1500. The first filler can be directly touching the core structure, or can be covered/encapsulated by other material, for example a thermoplastic film or carbon fiber, not limited to these materials. If the gap 1500 reaches the surface, the first filler 1600 can be exposed on the surface or can be covered with glass fiber, carbon fiber, adhesive or any other material.

FIG. 17 is a perspective view showing a frame added to the edge of the paddle from FIG. 16, according to an embodiment. After the gap 1500 is filled with the first filler 1600, a frame 1700 can be added to the edge (perimeter) as described herein. Note that in some embodiments, where there is no gap on the edge of the paddle, adding the frame may not be necessary. The frame 1700 can have a second filler as described herein. Note that the final paddle will appear as shown in FIGS. 7A and 7B.

FIG. 18 is a cross section of FIG. 17 showing the core, foam, and carbon frame, according to an embodiment. The frame 1700 contains a second filler 1800. FIG. 19 is a

8

perspective view showing a front of a completed paddle (FIG. 17) showing the first filler on the inside, according to an embodiment. The first filler 1600 is inside the gap 1500 cut inside the core 1400. The first filler 1600 is not visible to the user as it is entirely inside the paddle.

FIGS. 19-22 are each drawings showing a diagonal front view of a paddle, according to various embodiments. Note that the back view of each paddle would be identical to the respective front view. All other structures not shown would be the same as described herein. The paddles shown in FIGS. 19-22 can be constructed as described herein.

FIG. 19 is an example of a paddle showing the horizontal gap (and first filler) across the entire paddle, and was shown being constructed in FIGS. 15-18. FIG. 20 is an example of a paddle showing the horizontal gap (and first filler) just in the sides of the paddle. FIG. 21 is an example of a paddle showing the horizontal gap (and first filler) just in the center of the paddle. The gap (and first filler) is not limited to these examples or to horizontal gaps, and other shapes, dimensions, and configurations can be used as well. Note in FIGS. 19-21 (as in FIGS. 7D and 8-13), the first filler is completely inside the paddle and is not visible to the user. The second filler is also completely inside the paddle (inside the frame) and is also not visible to the user.

Note that when the gap and first filler is entirely in-between the head and the handle (the throat), it can be referred to as a dampener (such as shown in FIGS. 19-21). In other words, a dampener does not have any portion of filler outside of the throat of the paddle (e.g., above the throat line or below the top of the handle). Note that when the gap and the first filler is near the perimeter/edges of the paddle (such as shown in FIGS. 7D and 8-13) then it can affect properties of the paddle, which can for example increase spin and boost of the ball. This can be because the first filler (e.g., foam) inside the paddle, in one embodiment, can slightly vibrate when the paddle strikes a ball, which enhances the feel of the player when striking the ball. A dampener can reduce vibration on the handle. Note that in an embodiment, a dampener can be considered a piece of foam that is entirely inside the throat of the paddle. Note that in an embodiment, using the frame as described herein can be optional. In one embodiment, if a paddle contains a dampener, then there would not be a frame used.

Note that the ratio of volume of first filler to volume of the core can be relatively large (meaning there is a relatively large amount of first filler used in the paddle). For example, in a particular paddle, a ratio $r = \text{volume of all first filler} / \text{volume of all core}$. In an embodiment, the ratio r can be 5%. In another embodiment, r can be from 5% to 75%. In another embodiment, r can be from 25% to 50%. In another embodiment, r can be from 10% to 20%. In an embodiment, an acceptable range of r would be from 1% to 30%.

Note that both a dampener (gap with filler between the head and the handle) and gap with filler near the edge can also be combined into the same paddle, see FIGS. 8, 9, 22. FIG. 22 is a perspective view showing a front of another alternative paddle showing first filler both around the perimeter as well is throughout a section between the head and the handle, according to an embodiment.

FIG. 23 is a perspective view of a paddle with a gap cut through the front and back surfaces, according to an embodiment. Note in this embodiment, a gap 2300 is cut throughout the core, front and back surface of the paddle.

FIG. 24 is a perspective view of the paddle with the gap cut through the front and back surfaces with filler, according to an embodiment. A first filler 2400 is inserted into the gap 2300. The front surface and back surface can then be coated

US 12,465,826 B2

9

with an external coating (but alternatively could be visible without any coating/cover), such as a carbon fiber layer, to cover the entire front and back surface including the first filler **2400**. As such, the first filler **2400** would not be visible to a user after the external coating is applied. FIGS. **17**, **19-22** and **24** would all appear visually as FIGS. **7A**, **7B** since all of the internal structures (e.g., core **200**, first filler **400**, second filler **605**, etc.) would be covered by the front and back surfaces and possible the frame **600**.

FIG. **25** is a left side view of a completed paddle, according to an embodiment. FIG. **26** is a right side view of the completed paddle, according to an embodiment. FIG. **27** is a top view of the completed paddle, according to an embodiment. FIG. **28** is a bottom view of the completed paddle, according to an embodiment. Note that a completed (finished) paddle can appear on the outside as shown in FIGS. **7A** and **7B** as well as FIGS. **25-28**. Note that the surfaces shown in FIGS. **25-28** are all frame **600** although the shading does not match the shading used in the other FIGS with regard to the frame **600** in order to show the contours.

FIG. **29** is a drawing showing a perspective view of the frame, according to an embodiment. Shown is the frame which can be made out of carbon or other material. The frame (before curing/heating) is malleable so it can be bent around the perimeter of the paddle. It can be glued onto the edge of the paddle using glue or other adhesive. While shown with an open face in FIG. **29**, the face can be closed (sealed) on both ends, thereby creating an airtight frame in which pressurized air or other materials can be sealed therein.

FIG. **30** is a drawing of a completed paddle, according to an embodiment. The paddle can have an optional grip **3000**, an optional end cap **3001**, and an optional edge guard **3002**. The edge guard can be used or not to cover the frame and a small area of the surfaces on both sides. The edge guard can be made from PVC, any type of polymer, thermoplastic, thermoset, elastomer, rubber, foam, expandable material, or a mixture of any of these. Example dimensions (in inches) for such a paddle can be, 15-17" (length)×9-7" (width), or 16.5"×7.5" or 16"×8". Grip length: 4-6", or 4.75-5.75". Grip circumference: 4-4.5", or 4-4.3", although these are just examples and any other dimensions can be used. When determining the locations/dimensions of the head, throat, handle, face, etc., the edge guard, end cap, and grip are not used.

FIG. **31** is a flowchart illustrating a method used to construct a paddle, according to an embodiment. This method (and its individual operations) can be used to construct any paddle described or illustrated herein. All operations described herein can be applied to any embodiment described herein.

In operation **3101**, an original paddle can be constructed or provided. The original paddle will be constructed from core which can be comprised of any open-cell structure or lattice of polypropylene, aluminum, Nomex, Kevlar or any other synthetic or natural material. Outer surfaces (e.g., front surface and back surface) can be comprised of any material, for example one, two, three, four or more layers of unidirectional or weave of carbon, glass, or any natural or synthetic fiber and prepreg, impregnated with any kind of resin are commonly used for the outer surface. The front and back surface can be glued to the core, creating a "sandwich" of core between the front and back surfaces. See FIGS. **1A**, **1B**, **1C** for an original paddle. Note that in an embodiment, the front and back surface can be glued onto the core after the core is cored out, providing easier access to the core.

10

From operation **3101**, the method can proceed to operation **3102**, in which portions of the core are cored out (removed) to create a gap. This can be done by using a tool such as a router, running drill, press, saw, or any other mechanical tool. The coring can be performed through edges of the paddle (See FIG. **2**). In the embodiment where the intended gap does not touch the edge of the core, then the coring out of the core could be performed before assembling the sandwich structure (e.g., before attaching the front surface and back surface to the core). This method of coring out the core can also be done even if the gap does touch the edge of the core. The gap can be from 0.1 to 100 mm depth (from the edge to the center of the paddle), it can be continuous around all the paddle, or split in two, three, four or more sections of different lengths, depths, and shapes. The height of the gap can vary from 0.1 to 25 mm or to the max thickness of the core. The gap can be of any shape, concave, convex, U shape, or others. There can also be shapes created within the core while the core is attached to the edge.

From operation **3102**, the method proceeds to operation **3103**, in which a filler (first filler) is placed (inserted) into the gap. The filler can be pressurized (e.g., in a can) and sprayed in, or can be spread inside the gap using a tool (e.g., applicator gun (such as a foam dispensing gun), etc. The gap can be entirely filled in with the first filler or some gaps can still remain. In an embodiment, the first filler can be cut to the exact shape of the gap and added by hand. The first filler can be an empty space (or pressured air and the frame can be airtight), or filled with any type of polymer, thermoplastic, thermoset, thermoplastic elastomer, elastomer, rubber, foam, polymeric foam, expandable material, or a mixture of them. The first filler material can be expandable, for example if the first filler material is foam it can be expandable form. The first filler can be of any cross-section shape, the height can vary from 1 to 25 mm or to the max thickness of the core, the width (distance from the frame wall to the core) can vary from 0.1 to 50 mm. According to the gap geometries and shape, the first filler can be continuous around all the core or can be split in two, three, or more sections with same or different geometries, dimensions, and materials. The first filler can surround the entire paddle, just the head, or just specific areas.

From operation **3103**, the method can proceed to operation **3104**, which adds the frame to the edge of the paddle. The frame is a hollow cuboid structure (or other structure which does not have to be hollow) which wraps around the entire edge of the paddle. The frame can be bendable in order to mold it to the shape of the edge of the paddle. An adhesive (e.g., glue, cement, etc.) can be used to adhere the frame to the paddle. The frame (e.g., carbon frame) is bendable before the heating operation, but after the heating the resin sets and the frame becomes hard. The frame can be adhered to the paddle by the resin in the carbon fiber and because it gets hard it won't change the shape of the frame. The frame can be made of carbon, glass, fiberglass, thermoplastic, or any synthetic or natural fiber with resin, plastic, rubber, metal, or any material that provides a rigid structure. To make the carbon frame, a sheet of carbon fiber prepreg (impregnated with thermoset resin) is rolled to form a tube structure. Inside this tube there's a piece (continuous and long, about the same length of the tube) of the second filler (such as expandable foam). The frame can be of any cross-section shape, height, width, and length. It can be an entire piece or can be split in two, three, or more sections

US 12,465,826 B2

11

with same or different geometries and dimensions. The frame can surround the entire paddle, just the head, just the handle, or just specific areas.

The frame can be hollow or filled with a filler (second filler). This second filler can be of any polymer, thermo- 5 plastic, thermoset, thermoplastic elastomer, elastomer, rubber, foam, polymeric foam, expandable material, or a mixture of them. The second filler can be of any density, viscosity, and hardness. The second filler can be inserted into the frame using a number of alternate methods (in addition 10 to those described herein), such as blowing it inside, injecting it, pressuring the second filler and then shooting it inside the frame, etc. The second filler (e.g., expandable foam) can be inserted into carbon frame by hand, it is a solid piece before the hot molding process. The second filler can also be 15 air and the frame can be airtight.

From operation **3104**, the method proceeds to operation **3105**, which heats up the paddle. Once the first filler has been added to the paddle (inside gap(s) in the core) and the 20 frame has been added to surround the paddle, and the second filler is added inside the frame, and the front and back surface are attached (e.g., glued) to the core, then the paddle can be placed inside a mold. The frame can be bent around the edge (perimeter) of the paddle. The paddle can then be 25 heated in the mold which has a shape to match the paddle. The mold is closed with high pressure inside and the temperature is raised inside the mold to around 100 degrees Celsius or more for 2-20 minutes or more. With the high temperature, the second filler inside the frame expands so 30 the frame gets its shape. The first filler inside the gap(s) also can expand therein. If expandable foam (e.g., a polymer with a foamy agent) is being used for the first filler and/or the second filler, then the expandable foam can expand and harden when heated. Also, with the high temperature, the resin impregnated in the frame sets (becomes hard) so it will be a solid piece after the mold is opened.

Note that all features, embodiments, method, step, etc., can be applied to any other embodiment described herein. In addition, all features, embodiments, methods, steps, etc., can be combined with any other without limitation. In addition, all paddles herein are (unless stated otherwise) symmetrical, that is the back side/surface would be identical to the front side/surface. For any side or portion of any paddle that is not shown or described in the drawings/specification, that side or portion can be identical (symmetrical) to its correspond- 45 ing side or portion that has been shown (or identical/symmetrical to other paddles shown herein). For example, if the left side of a paddle is shown, if the right side of the paddle is not shown or described, it can be assumed that the appearance and structure of the right side is identical to the 50 left. If the bottom of a paddle is not shown, it can be assumed that the bottom of that paddle is identical to a bottom shown of any other paddle shown herein. As such, parts and structures described herein can be combined and mixed without limitation. The same would hold true for front and back surfaces, etc. Any part mentioned or illustrated can be made from any suitable material, including any material mentioned herein.

The many features and advantages of the invention are apparent from the detailed specification and, thus, it is intended by the appended claims to cover all such features and advantages of the invention that fall within the true spirit and scope of the invention. Further, since numerous modifications and changes will readily occur to those skilled in the art, it is not desired to limit the invention to the exact construction and operation illustrated and described, and 65

12

accordingly all suitable modifications and equivalents may be resorted to, falling within the scope of the invention.

What is claimed is:

1. A pickleball paddle, comprising:
 - a front surface;
 - a back surface opposing the front surface;
 - a core disposed between the front surface and the back surface, the core having an outer boundary including:
 - (i) a first portion shaped and dimensioned to terminate internal to, and spaced apart from, an internal perimeter of the pickleball paddle, and (ii) a second portion shaped and dimensioned to terminate closer to the internal perimeter of the pickleball paddle relative to the first portion;
 - a gap formed as a void external to the core and positioned between the outer boundary of the core and the internal perimeter of the pickleball paddle, the gap extending around at least the first portion of the outer boundary of the core;
 - a first filler disposed within at least a portion of the gap beyond the outer boundary of the core;
 - a frame disposed about at least a head portion of the pickleball paddle along an edge portion thereof, the frame at least partially disposed between the front surface and the back surface along the edge portion, the frame defining a hollow interior portion; and
 - a second filler disposed within at least a portion of the hollow interior portion of the frame.
2. The pickleball paddle of claim 1, wherein one or more of the first filler and the second filler includes a foam material.
3. The pickleball paddle of claim 1, wherein one or more of the first filler and the second filler include at least one of: a polymer, a thermoplastic, a thermoset material, a thermoplastic elastomer, an elastomer, a rubber, and an expandable material.
4. The pickleball paddle of claim 1, wherein one or more of the first filler and the second filler includes pressurized air.
5. The pickleball paddle of claim 1, wherein the second filler and the first filler are the same material.
6. The pickleball paddle of claim 1, wherein the second filler and the first filler are different materials.
7. The pickleball paddle of claim 1, wherein the gap is disposed, at least in part, between the frame and the core.
8. The pickleball paddle of claim 7, wherein the gap borders the frame.
9. The pickleball paddle of claim 1, wherein the frame surrounds the entire pickleball paddle.
10. The pickleball paddle of claim 1, wherein the frame include carbon fiber.
11. The pickleball paddle of claim 1, wherein the frame is a hollow cuboid structure.
12. The pickleball paddle of claim 11, wherein the hollow cuboid structure is formed from a single piece of material.
13. The pickleball paddle of claim 1, wherein the core at least partially includes a honeycomb structure.
14. The pickleball paddle of claim 1, further comprising an edge guard covering at least a portion of the frame along at least part of the head portion of the pickleball paddle.
15. The pickleball paddle of claim 1, wherein the outer boundary of the core further includes a third portion connecting the first portion and the second portion, the third portion projecting inwardly away from the internal perimeter of the pickleball paddle.
16. The pickleball paddle of claim 1, wherein the second filler is an expandable foam.

US 12,465,826 B2

13

14

17. The pickleball paddle of claim 1, wherein the second filler is air.

18. The pickleball paddle of claim 1, wherein the first filler includes a vibration dampener.

19. The pickleball paddle of claim 1, wherein the first filler partially fills the gap.

20. The pickleball paddle of claim 1, wherein the frame defines an airtight structure.

* * * * *

EXHIBIT 2

**Exhibit 2 to Complaint
Infringement Claim Chart
U.S. Patent No. 12,465,826**

**Vegas Pickleball LLC d/b/a RPM Pickleball
Friction Pro Paddle**

The exemplary claim chart set forth below is provided based on information to date and may not be exhaustive. Plaintiff's investigation is ongoing. Plaintiff reserves the right to supplement and/or amend this exemplary infringement contention claim chart to identify additional asserted claims, accused products/instrumentalities, and/or to further identify where each element of each asserted claim is found in each accused product. For example, Plaintiff reserves the right to supplement and/or amend this exemplary infringement contention chart in view of any future discovery obtained from Defendant and/or third parties during the pendency of this litigation.

As used in claim chart below, the "RPM Accused Product(s)" include without limitation the following: the pickleball game paddles produced by Defendant Vegas Pickleball LLC d/b/a RPM Pickleball (hereinafter "RPM") including, but not necessarily limited to, Friction Pro paddles, as well as any other RPM product that shares a similar structure/configuration and/or operates in a manner consistent with the theory of infringement outlined in the claim chart below. Plaintiff contends that the RPM Accused Product(s)—which is also herein referred to as the Friction Pro—practices each of the claims of U.S. Patent No. 12,465,826 ("the '826 Patent") identified in the claim chart below in the manner shown and/or explained.

The RPM Accused Product(s)—along with the associated photographs and documents—discussed, cited, and/or otherwise referenced herein are representative in all material aspects of all other Accused Product(s) identified herein.

| | U.S. Patent No. 12,465,826 | RPM Friction Pro |
|----------------|----------------------------------|---|
| | Claim 1 | |
| 1 [pre] | A pickleball paddle, comprising: | <p>The RPM Friction Pro Paddle is a pickleball paddle. https://rpmpb.com/products/rpm-friction-pro-16mm-elongated-v2.</p>  |
| | | |

| | U.S. Patent No. 12,465,826 | RPM Friction Pro |
|------------|----------------------------|--|
| 1.a | a front surface; | The RPM Friction Pro Paddle includes a front surface (below):  |

| | U.S. Patent No. 12,465,826 | RPM Friction Pro |
|------------|--|--|
| 1.b | a back surface opposing the front surface; | <p>The RPM Friction Pro Paddle includes a back surface (below) opposing the front surface:</p>  |

| | U.S. Patent No. 12,465,826 | RPM Friction Pro |
|------------|---|---|
| 1.c | a core disposed between the front surface and the back surface, | <p>The RPM Friction Pro Paddle includes a core disposed between the front surface and the back surface, specifically a polypropylene core:</p>  <p>The image consists of three cross-sectional photographs of a paddle, arranged vertically. Each photograph shows the internal structure of the paddle. A central layer, labeled 'core' in red text, is made of a grey, honeycomb-patterned material. This core is sandwiched between two outer layers, labeled 'front/back surfaces' in yellow text. The top and bottom surfaces are a light-colored, possibly fibrous material. The middle layer is a red material. The paddle is held in place by a white support structure. The background is dark blue.</p> <p>https://www.mattspickleball.com/paddle/friction-pro-elongated-16mm</p> |

| | U.S. Patent No. 12,465,826 | RPM Friction Pro |
|------------|--|--|
| 1.d | the core having an outer boundary including a first portion shaped and dimensioned to terminate internal to, and spaced apart from, an internal perimeter of the pickleball paddle, and a second portion shaped and dimensioned to terminate closer to the internal perimeter of the pickleball paddle relative to the first portion | The RPM Friction Pro Paddle includes a core having an outer boundary including a first portion shaped and dimensioned to terminate internal to, and spaced apart from, an internal perimeter of the pickleball paddle, and a second portion shaped and dimensioned to terminate closer to the internal perimeter of the pickleball paddle relative to the first portion: |

| | U.S. Patent No. 12,465,826 | RPM Friction Pro |
|-------------------|---|--|
| | |  |
| <p>1.e</p> | <p>a gap formed as a void external to the core and positioned between the outer boundary of the core and the internal perimeter of the pickleball paddle,</p> | <p>The RPM Friction Pro Paddle includes a gap formed as a void external to the core and positioned between the outer boundary of the core and the internal perimeter of the pickleball paddle:</p> |

| | U.S. Patent No. 12,465,826 | RPM Friction Pro |
|-------------------|---|---|
| | |  <p>The photograph shows three RPM Friction Pro paddles laid out horizontally. Each paddle has a honeycomb-like core. A yellow box with the word 'gap' is positioned between the middle and bottom paddles. Green arrows point from this box to the gaps between the paddles, specifically highlighting the area where the core material is missing or separated at the top and bottom edges of the core sections.</p> |
| <p>1.f</p> | <p>the gap extending around at least the first portion of the outer boundary of the core;</p> | <p>The RPM Friction Pro Paddle includes a gap extending around at least the first portion of the outer boundary of the core:</p> |

| | U.S. Patent No. 12,465,826 | RPM Friction Pro |
|-------------------|--|---|
| | |  |
| <p>1.g</p> | <p>a first filler disposed within at least a portion of the gap beyond the outer boundary of the core;</p> | <p>The RPM Friction Pro Paddle includes a first filler disposed within at least a portion of the gap beyond the outer boundary of the core:</p> |

| | U.S. Patent No. 12,465,826 | RPM Friction Pro |
|-------------------|---|---|
| | |  <p>The photograph shows three cross-sectional views of a pickleball paddle head. The top view shows a honeycomb core with a red layer labeled 'first filler' on the right side. A green label 'gap' points to a space between the core and the outer shell. The middle view shows a similar cross-section with the 'first filler' layer more prominent. The bottom view shows another cross-section, also with the 'first filler' layer and the 'gap' label. The paddle is held against a dark blue background.</p> |
| <p>1.h</p> | <p>a frame disposed about at least a head portion of the pickleball paddle along an edge portion thereof,</p> | <p>The RPM Friction Pro Paddle includes a frame disposed about at least a head portion of the pickleball paddle along an edge portion thereof:</p> |

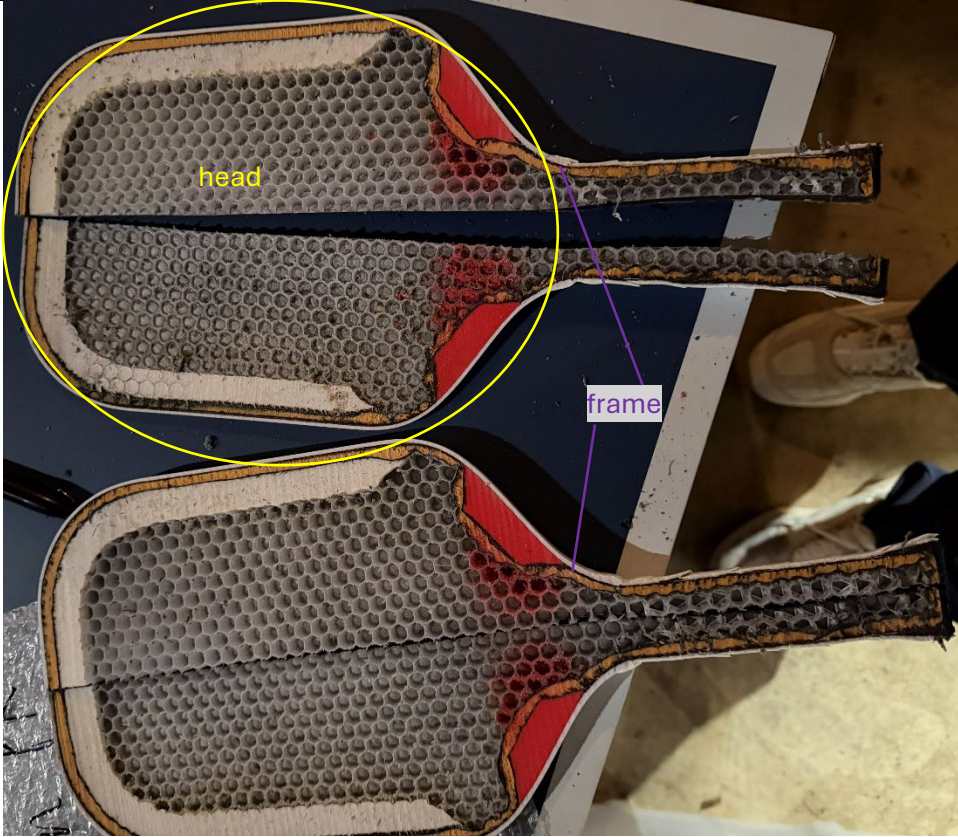
| | U.S. Patent No. 12,465,826 | RPM Friction Pro |
|-------------------|---|--|
| | |  |
| <p>1.i</p> | <p>the frame at least partially disposed between the front surface and the back surface along the edge portion,</p> | <p>The RPM Friction Pro Paddle includes a frame at least partially disposed between the front surface and the back surface along the edge portion:</p> |

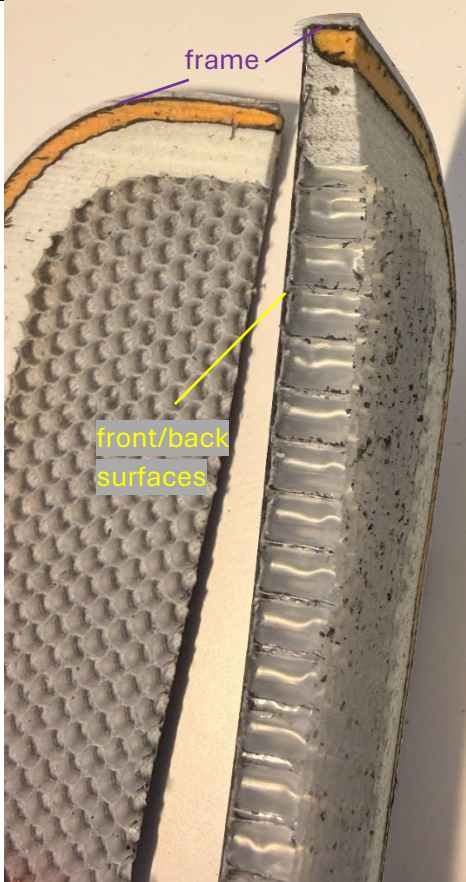
| | U.S. Patent No. 12,465,826 | RPM Friction Pro |
|------------|---|---|
| | |  <p>The photograph shows a cross-section of a paddle. A purple arrow points to the outer edge, labeled 'frame'. A yellow arrow points to the textured interior surface, labeled 'front/back surfaces'. The interior surface has a honeycomb-like pattern, and the outer surface has a series of horizontal ridges.</p> |
| 1.j | the frame defining a hollow interior portion; and | The RPM Friction Pro Paddle includes a frame defining a hollow interior portion: |

| | U.S. Patent No. 12,465,826 | RPM Friction Pro |
|-------------------|--|--|
| | |  <p>The image shows two cross-sectional views of the RPM Friction Pro paddle. The top view shows a paddle with a hollow interior filled with a porous, grey material. A label points to this area: "Hollow interior portion, shown here with filler". A second label points to the outer shell: "frame". The bottom view shows a similar paddle, also with a porous interior and a frame. The paddle is shown against a dark background, and a white object is visible in the lower right corner.</p> |
| <p>1.k</p> | <p>a second filler disposed within at least a portion of the hollow interior portion of the frame.</p> | <p>The RPM Friction Pro Paddle includes a second filler disposed within at least a portion of the hollow interior portion of the frame:</p> |

| | U.S. Patent No. 12,465,826 | RPM Friction Pro |
|--|----------------------------|---|
| | |  <p>The image shows a cross-section of a shoe sole, likely a running shoe, with a honeycomb-like structure. The sole is cut into two pieces, one above the other, to reveal the internal structure. The top piece is labeled with a pink box and text: "Hollow interior portion, shown here with filler therein". The bottom piece is labeled with a red box and text: "second filler". The sole is shown against a dark blue background, and a white shoe is visible in the background.</p> |

EXHIBIT 3



US012357891B2

(12) **United States Patent**
Kachiwazaki et al.

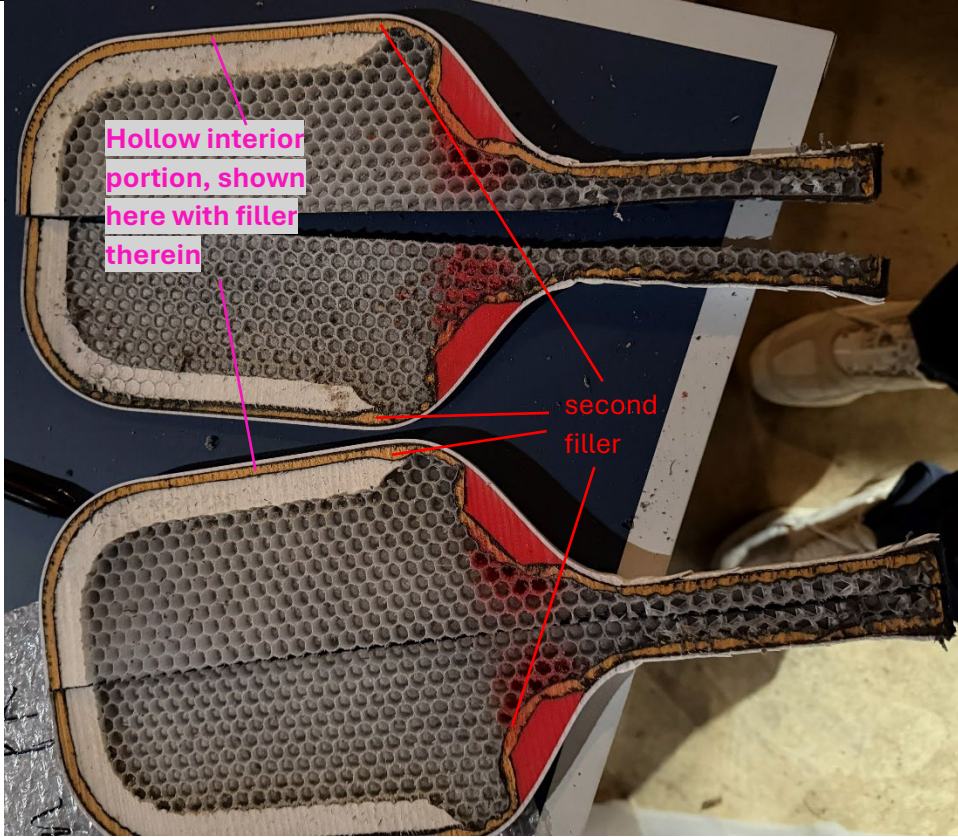
(10) **Patent No.:** **US 12,357,891 B2**
(45) **Date of Patent:** **Jul. 15, 2025**

(54) **GAME PADDLE**

(71) Applicant: **Sport Squad, Inc.**, Rockville, MD (US)

(72) Inventors: **Fabio Kachiwazaki**, São Paulo (BR);
Austin Kim, Columbia, MD (US);
Richard Lee, Potomac, MD (US)

(73) Assignee: **Sport Squad, Inc.**, Rockville, MD (US)

(*) Notice: Subject to any disclaimer, the term of this patent is extended or adjusted under 35 U.S.C. 154(b) by 0 days.

(21) Appl. No.: **19/028,832**

(22) Filed: **Jan. 17, 2025**

(65) **Prior Publication Data**

US 2025/0161772 A1 May 22, 2025

Related U.S. Application Data

(63) Continuation of application No. PCT/US2024/042535, filed on Aug. 15, 2024, which
(Continued)

(51) **Int. Cl.**
A63B 59/42 (2015.01)
A63B 60/54 (2015.01)
(Continued)

(52) **U.S. Cl.**
CPC *A63B 59/42* (2015.10); *B32B 3/08*
(2013.01); *B32B 3/12* (2013.01); *B32B 5/02*
(2013.01);
(Continued)

(58) **Field of Classification Search**
CPC *A63B 59/40*; *A63B 59/42*; *A63B 60/54*;
A63B 60/40; *A63B 59/45*; *A63B 59/48*
See application file for complete search history.

(56) **References Cited**

U.S. PATENT DOCUMENTS

3,879,035 A 4/1975 Danchulis et al.
3,949,988 A * 4/1976 Staufer A63B 49/11
264/45.2

(Continued)

FOREIGN PATENT DOCUMENTS

CN 219167665 U 6/2023
WO 2022182992 A1 9/2022

(Continued)

OTHER PUBLICATIONS

U.S. Appl. No. 63/535,565, filed Aug. 30, 2023, Fabio Kachiwazaki.
(Continued)

Primary Examiner — Michael D Dennis

(74) *Attorney, Agent, or Firm* — Bass Patent Law, LLC

(57) **ABSTRACT**

The present teachings generally include game paddles such as pickleball paddles. For example, a pickleball paddle disclosed herein may include a first surface, a second surface, and a core disposed therebetween, where the core defines a plurality of gaps that can accommodate one or more fillers, e.g., to provide vibration dampening and/or to otherwise affect performance, comfort, and enjoyment. In an example aspect, a gap is disposed on each side of the paddle near a throat portion thereof, where a first filler is inserted therein. The first filler may be viewable within such gaps—e.g., where an edge guard includes a window for viewing the first filler. A paddle according to the present teachings may have a frame (e.g., a frame that accommodates one or more gaps) or it may be frameless. In some aspects, a frame may also or instead include a filler disposed therein and/or adjacent thereto.

29 Claims, 38 Drawing Sheets

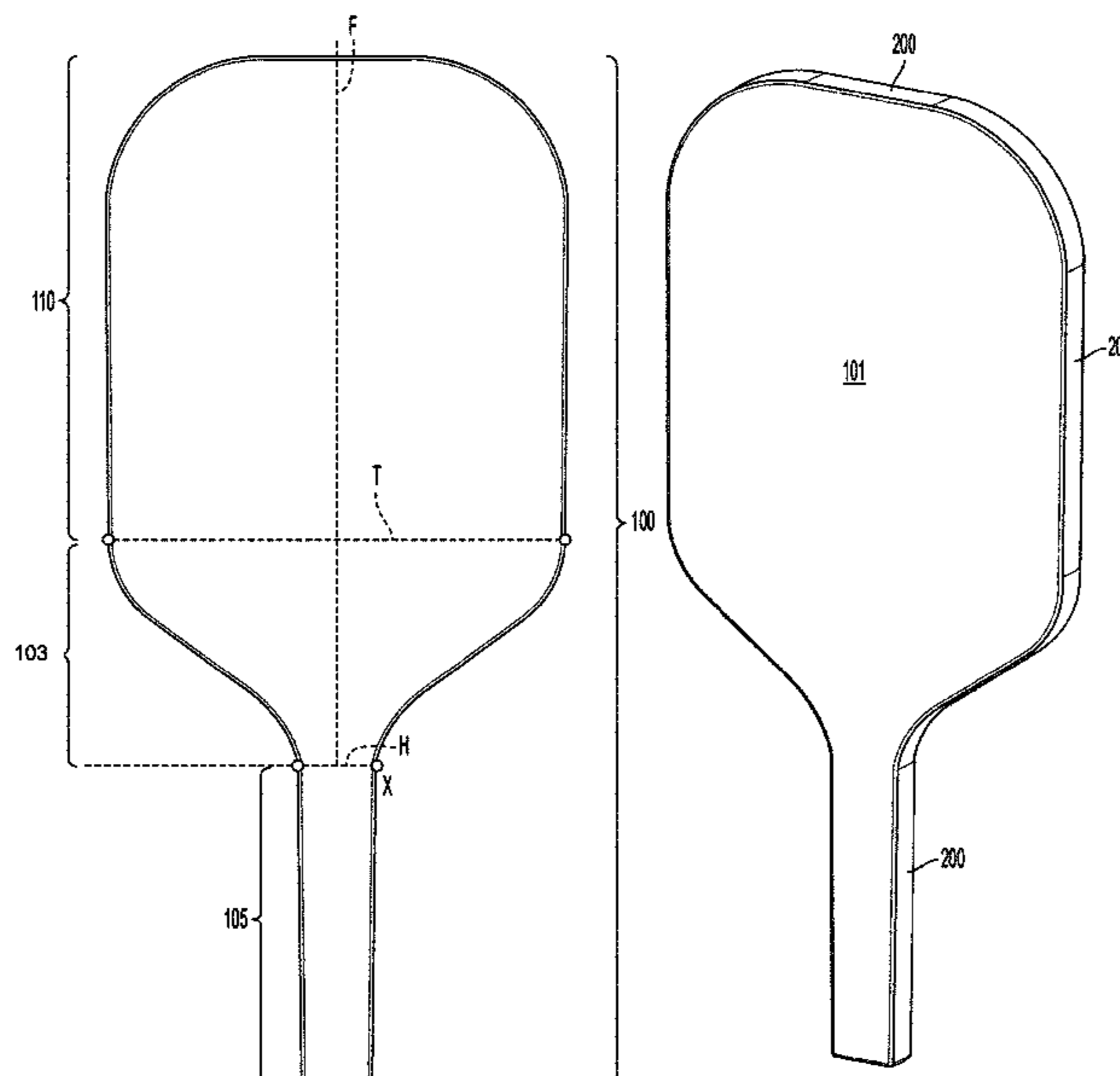

US 12,357,891 B2

Related U.S. Application Data

is a continuation of application No. 18/389,174, filed on Nov. 13, 2023.

(60) Provisional application No. 63/543,865, filed on Oct. 12, 2023, provisional application No. 63/535,565, filed on Aug. 30, 2023.

(51) **Int. Cl.**
B32B 3/08 (2006.01)
B32B 3/12 (2006.01)
B32B 5/02 (2006.01)
B32B 5/18 (2006.01)

(52) **U.S. Cl.**
 CPC *B32B 5/18* (2013.01); *A63B 60/54* (2015.10); *A63B 2209/02* (2013.01); *B32B 2262/106* (2013.01); *B32B 2266/0214* (2013.01)

(56) **References Cited**

U.S. PATENT DOCUMENTS

| | | | | |
|--------------|------|---------|----------------|-----------------------|
| 4,192,506 | A | 3/1980 | Sofia | |
| 4,194,738 | A | 3/1980 | Inoue et al. | |
| 4,331,331 | A | 5/1982 | Rodgers, Jr. | |
| 4,379,554 | A * | 4/1983 | Schuyler | A63B 59/40 473/530 |
| 5,172,911 | A | 12/1992 | Chang | |
| 5,649,873 | A | 7/1997 | Fuller | |
| 10,377,093 | B2 | 8/2019 | Filippini | |
| 2011/0201461 | A1 * | 8/2011 | Gazzara | A63B 60/50 473/527 |
| 2015/0224370 | A1 | 8/2015 | Yamamoto | |
| 2017/0021247 | A1 | 1/2017 | Marvin | |

| | | | | |
|--------------|------|---------|---------------|------------|
| 2017/0136325 | A1 | 5/2017 | Fox et al. | |
| 2018/0104555 | A1 | 4/2018 | Taylor | |
| 2018/0353820 | A1 | 12/2018 | Davis | |
| 2020/0290243 | A1 | 9/2020 | Avnery et al. | |
| 2020/0360778 | A1 | 11/2020 | Lee | |
| 2021/0252356 | A1 * | 8/2021 | Thurman | A63B 59/42 |
| 2021/0252357 | A1 | 8/2021 | Lee | |
| 2021/0260452 | A1 * | 8/2021 | Zheng | B32B 3/04 |
| 2022/0032141 | A1 * | 2/2022 | Brents | A63B 60/54 |
| 2023/0047371 | A1 | 2/2023 | Lee | |
| 2023/0149784 | A1 | 5/2023 | Lee | |
| 2023/0191215 | A1 | 6/2023 | Barnes et al. | |
| 2023/0415010 | A1 | 12/2023 | Luo | |
| 2024/0165468 | A1 | 5/2024 | Shu | |

FOREIGN PATENT DOCUMENTS

| | | | |
|----|------------|----|--------|
| WO | 2024076417 | A1 | 4/2024 |
| WO | 2025049122 | A1 | 3/2025 |

OTHER PUBLICATIONS

U.S. Appl. No. 63/543,865, filed Oct. 12, 2023, Fabio Kachiwazaki. Gearbox, "Pro Power Elongated," <https://gearboxsports.com/collections/all-pickleball-paddles/products/pro-power-elongated>, 2023, 9 pages.
 ISA/EP, PCT Application No. PCT/US24/42535, International Search Report and Written Opinion dated Nov. 12, 2024, 15 pages.
 Image of cutaway of Selkirk LABS Project 002 paddle (Aug. 2023), 1 page.
 Selkirk LABS Project 002, website captured by Wayback Machine on Jun. 2, 2022, currently available at <https://www.selkirklabs.com/products/selkirk-labs-project-002> (website capture date is Jun. 2, 2022), 3 pages.
 USPTO, U.S. Appl. No. 19/027,671, Non-Final Office Action dated Apr. 4, 2025, 29 pages.

* cited by examiner

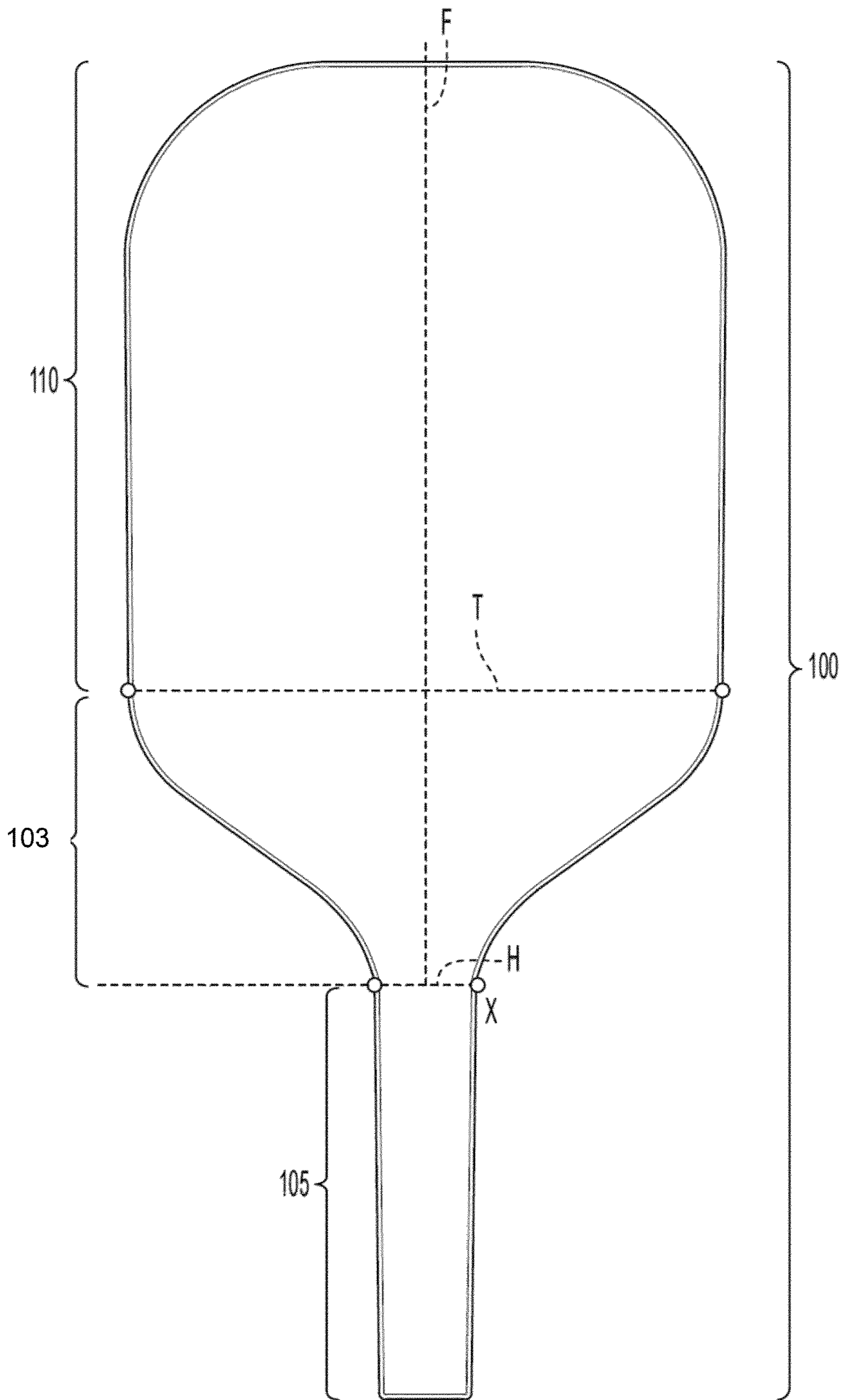

FIG. 1A

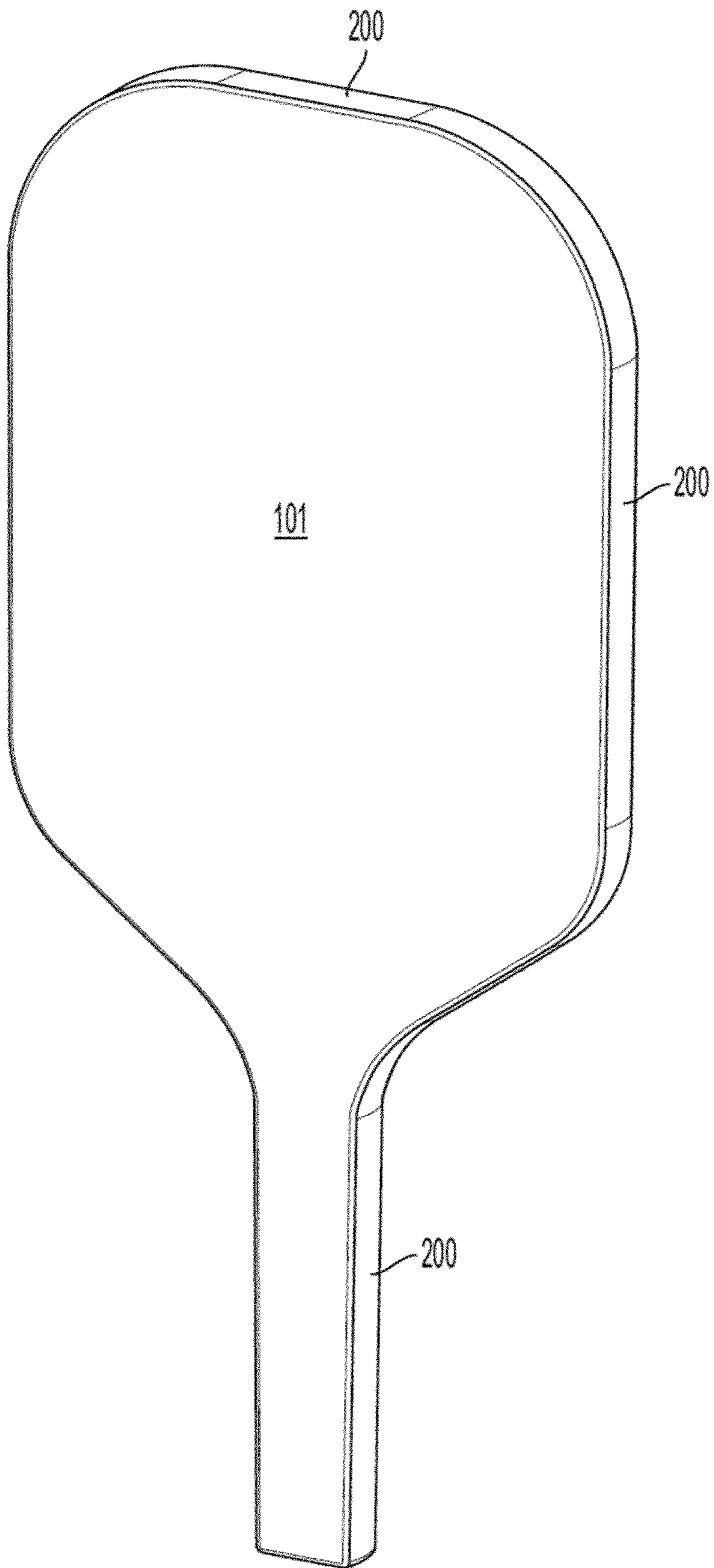

FIG. 1B

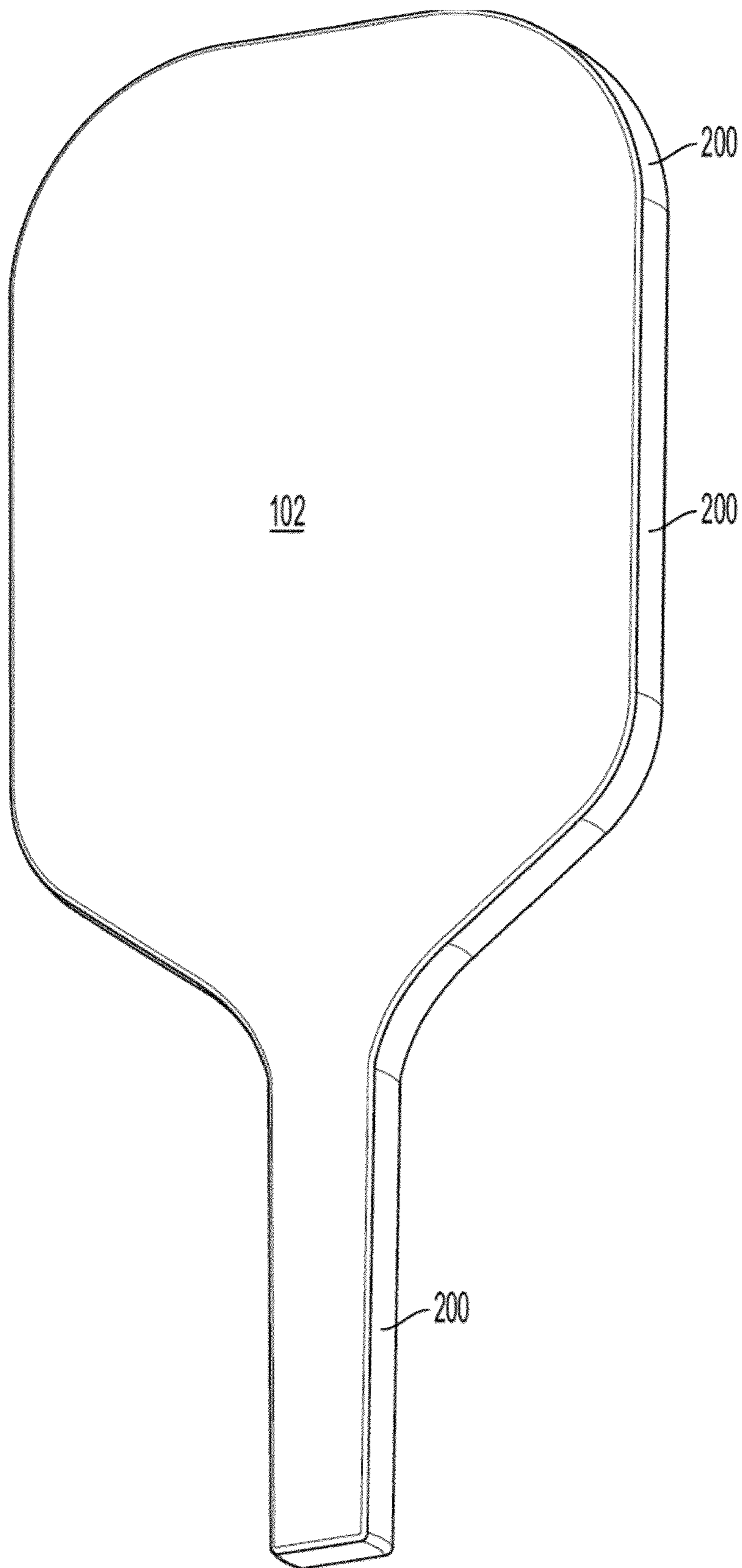

FIG. 1C

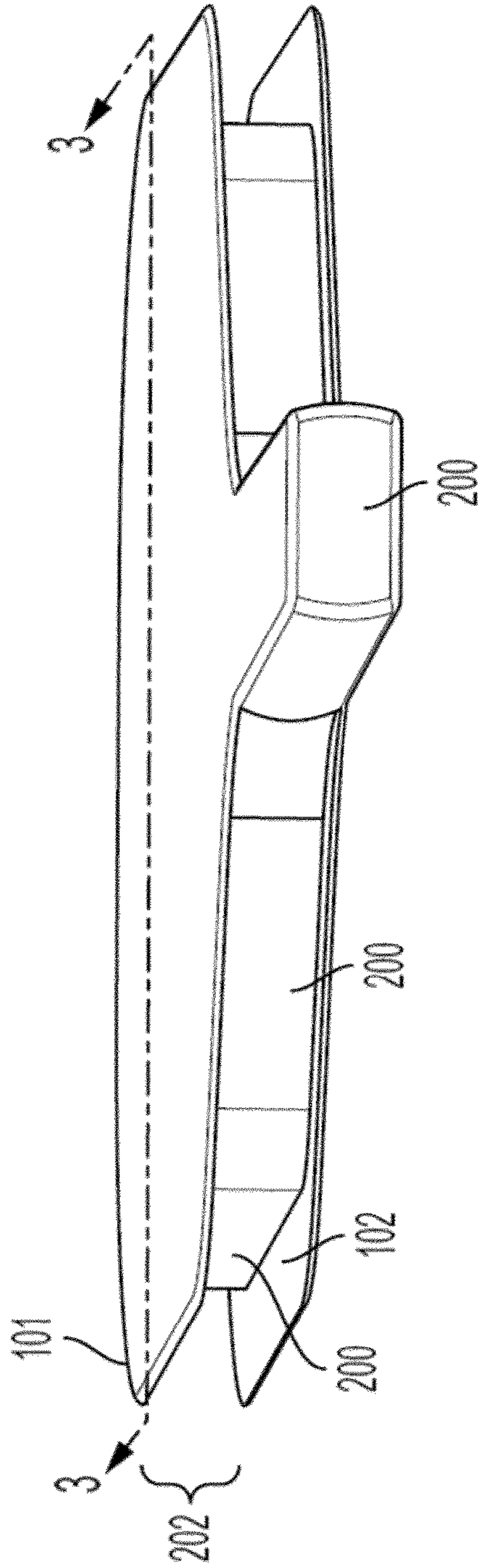

FIG. 2

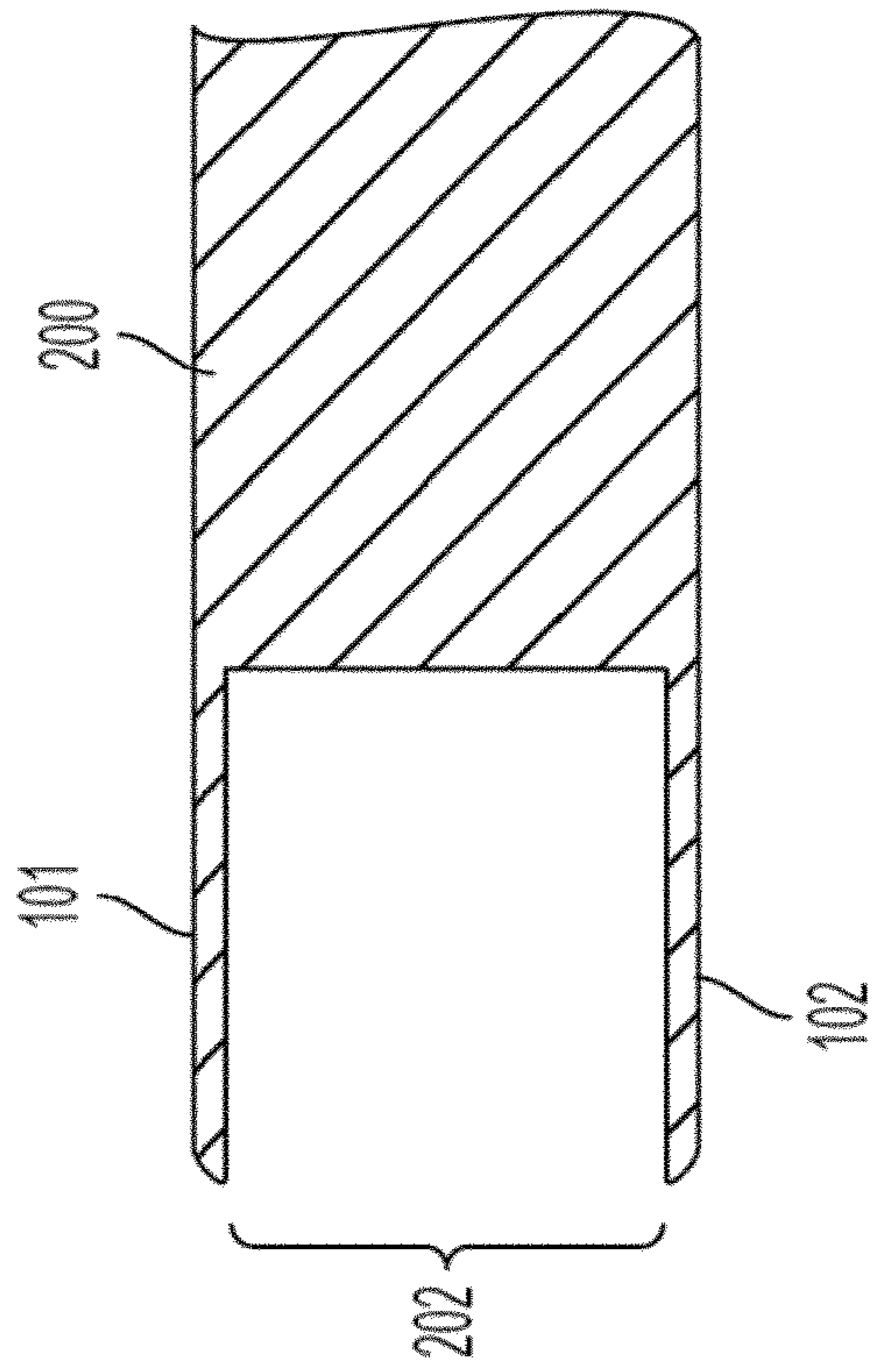

FIG. 3

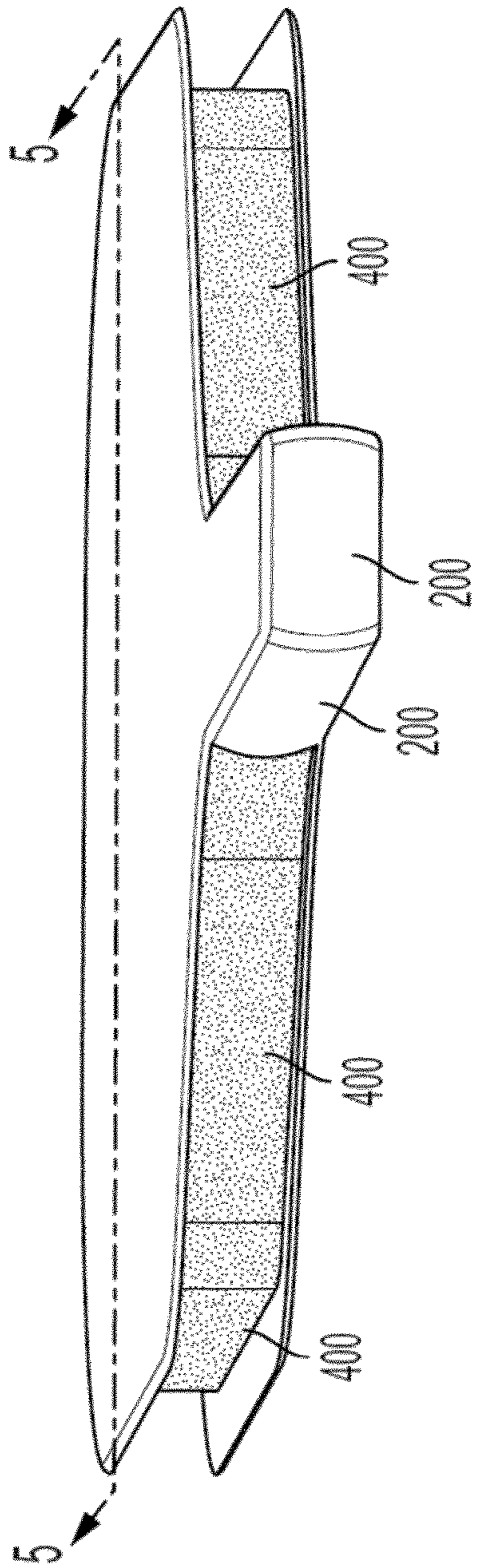

FIG. 4

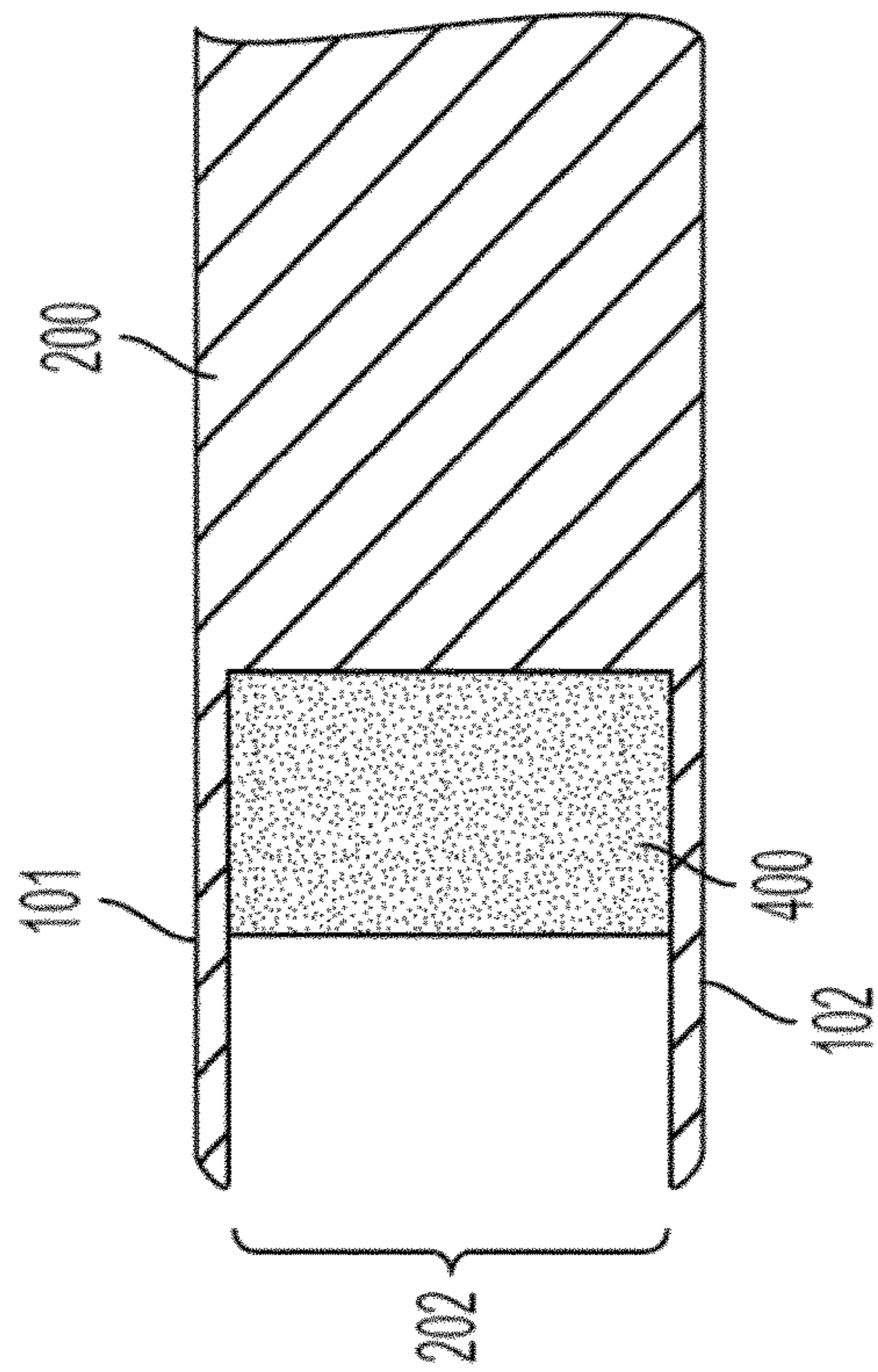

FIG. 5

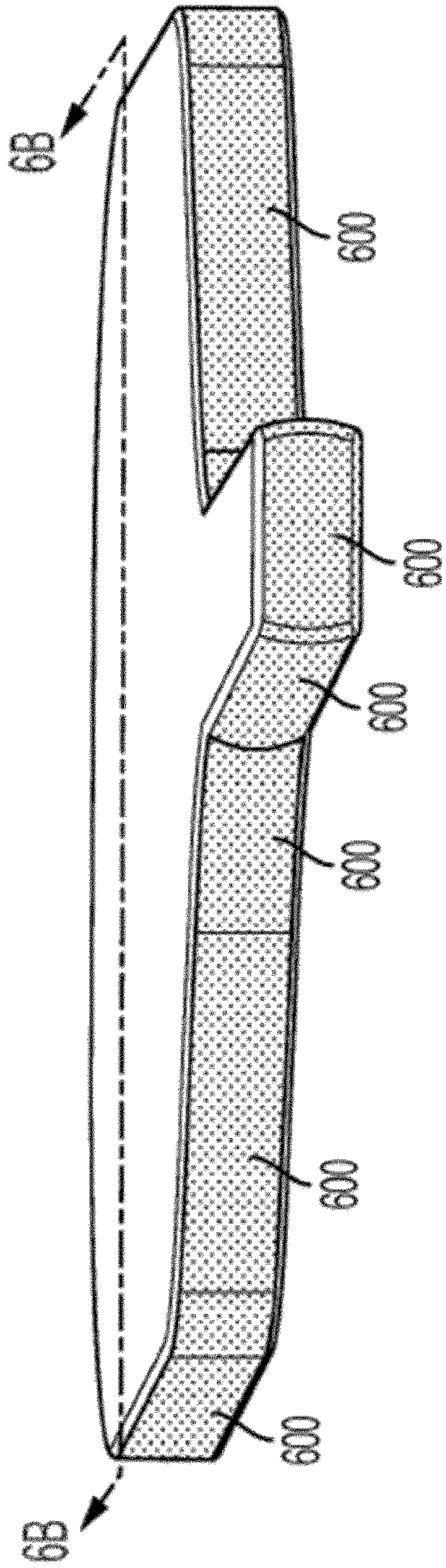

FIG. 6A

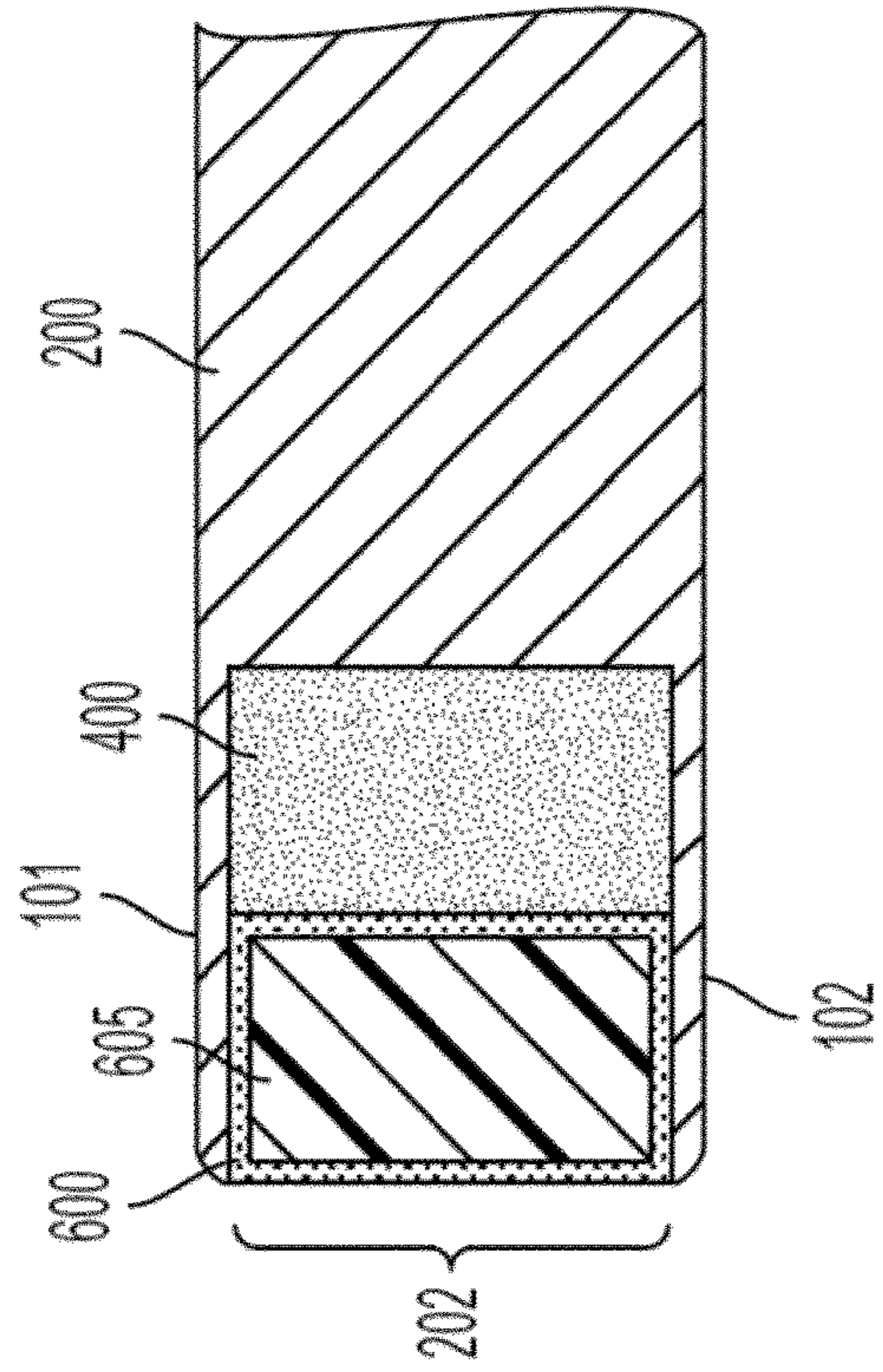

FIG. 6B

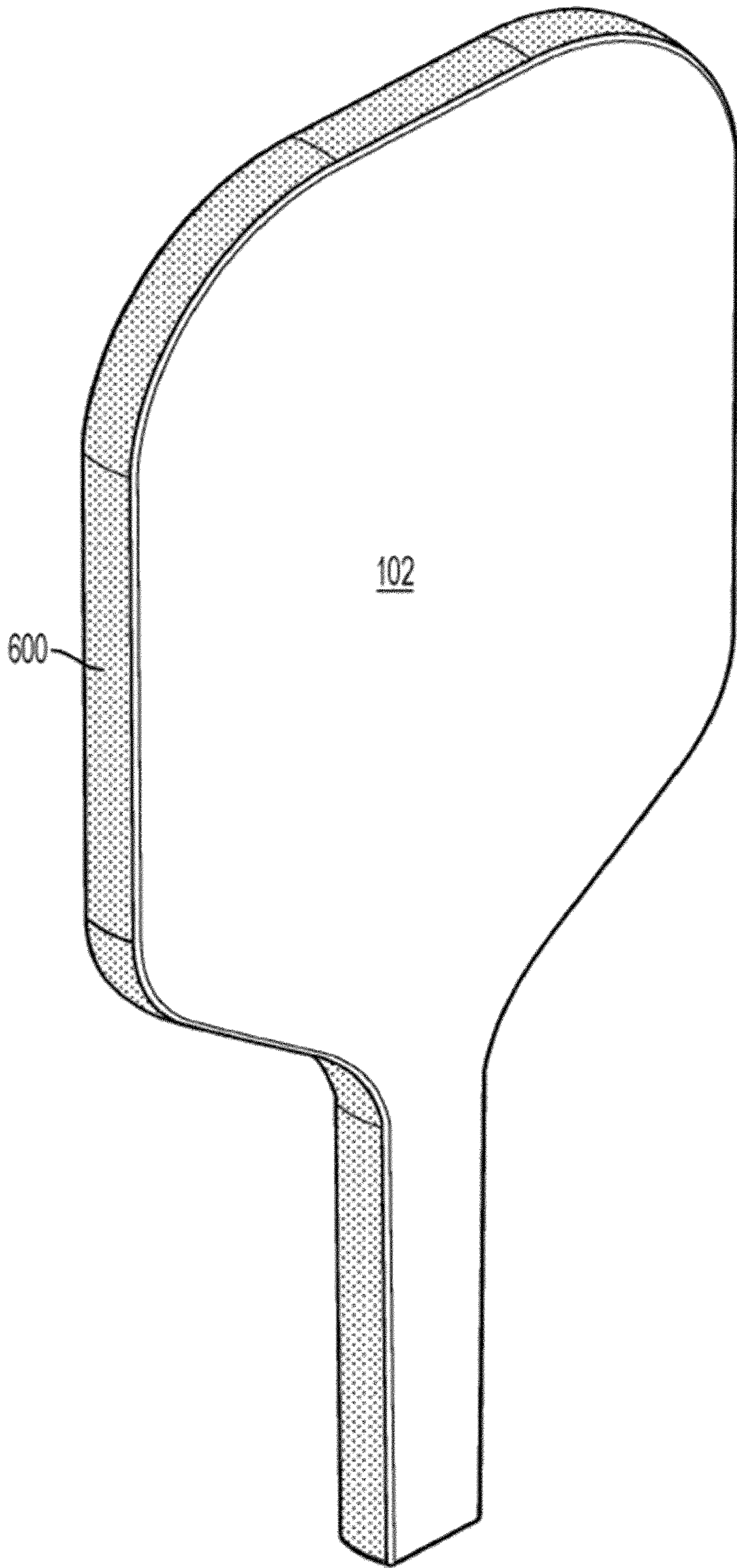

FIG. 7A

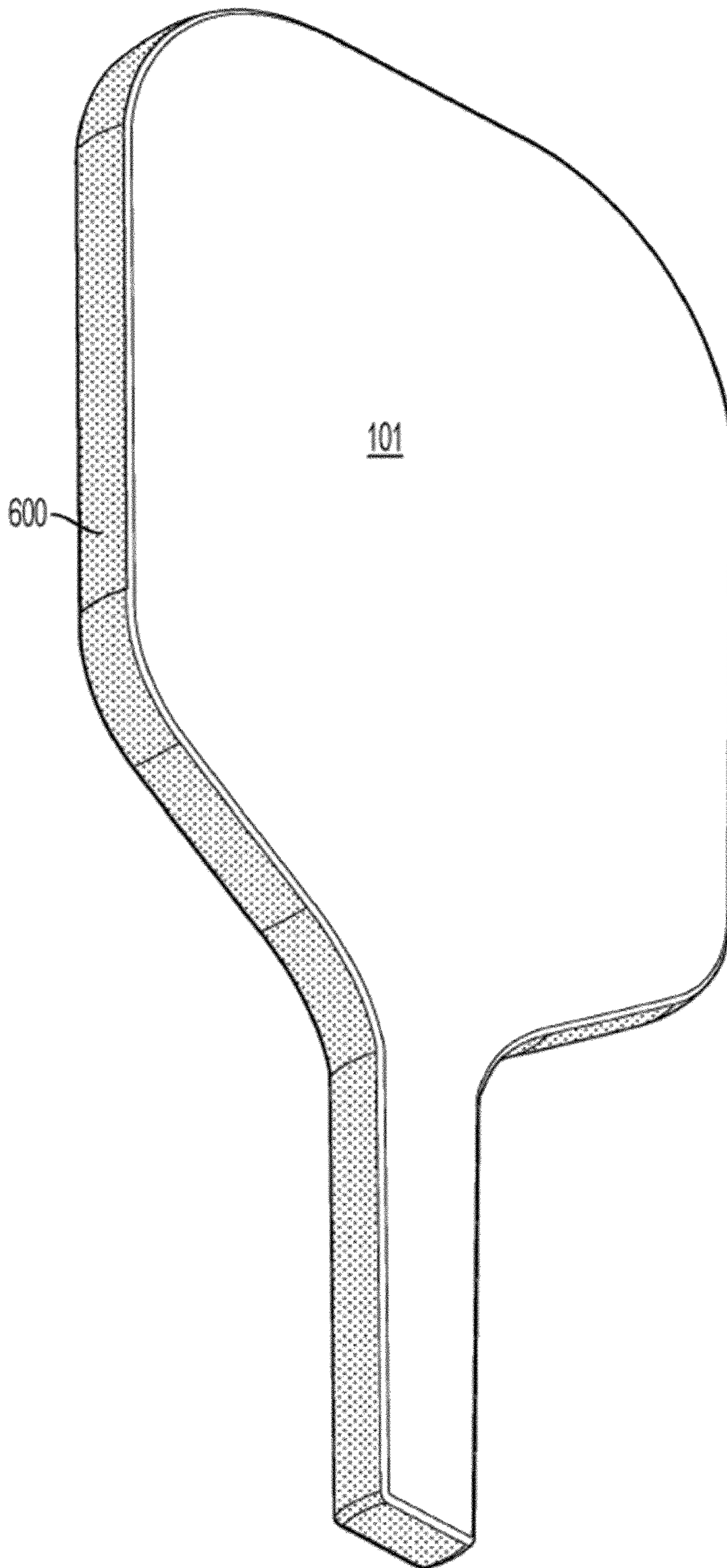

FIG. 7B

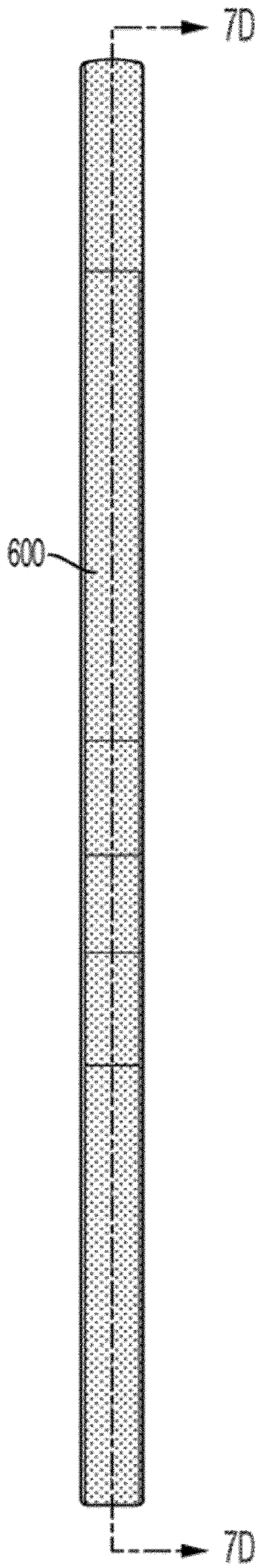

FIG. 7C

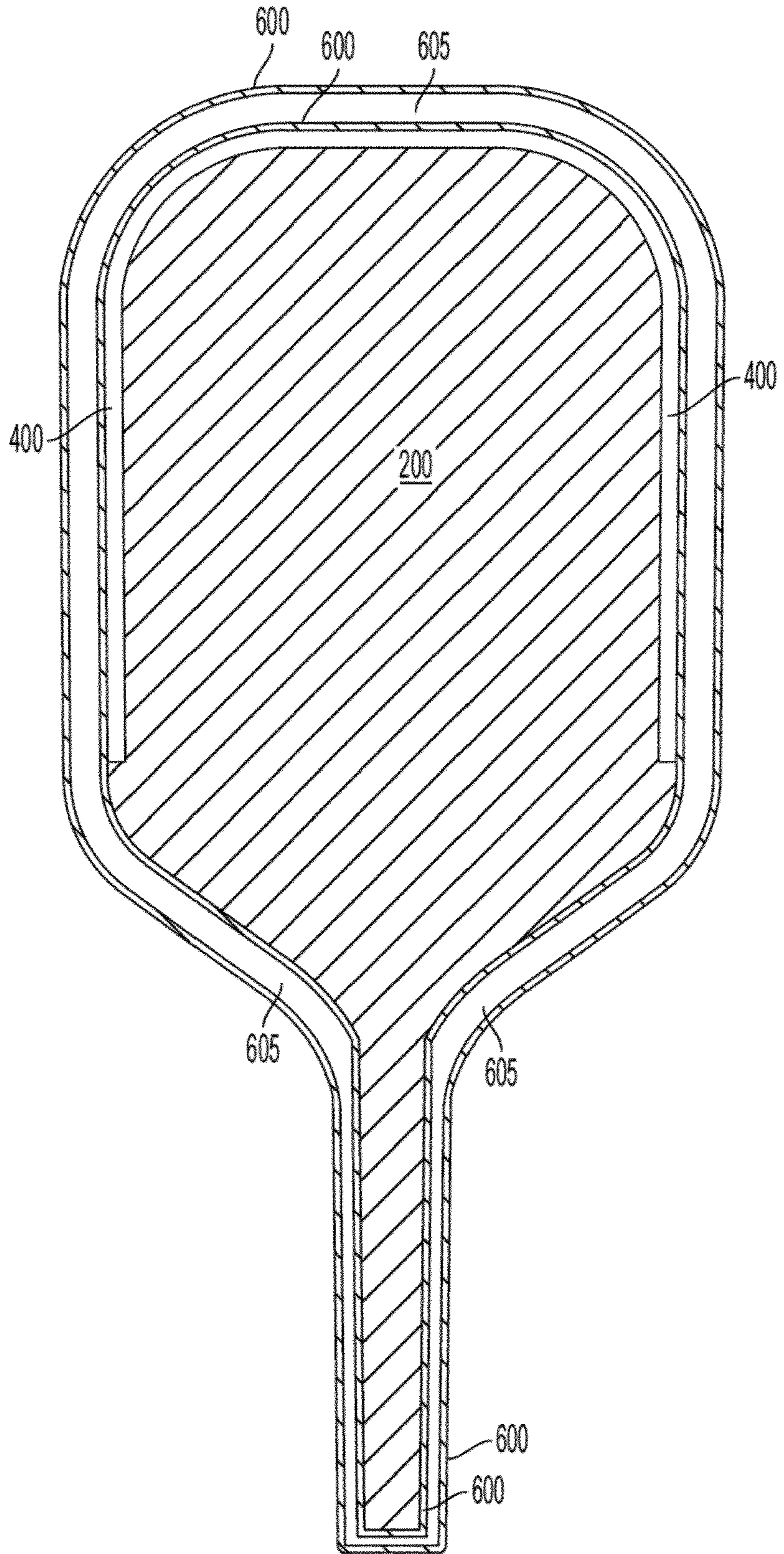

FIG. 7D

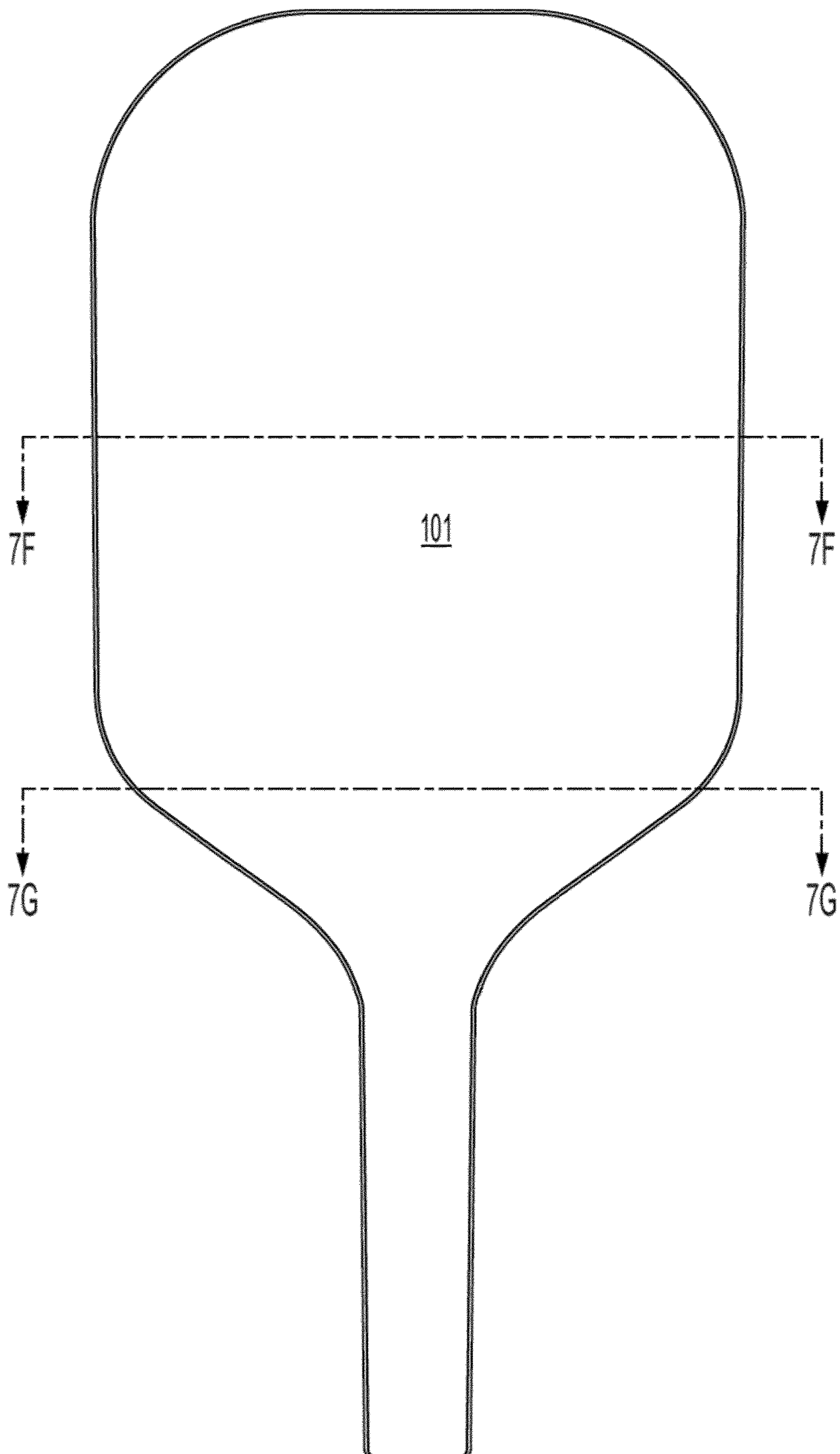

FIG. 7E

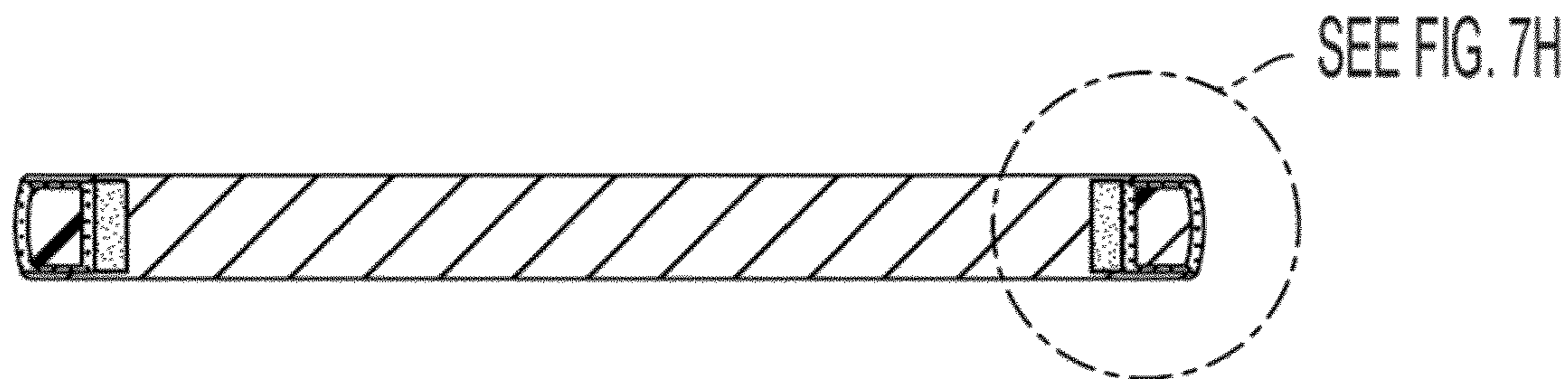

FIG. 7F

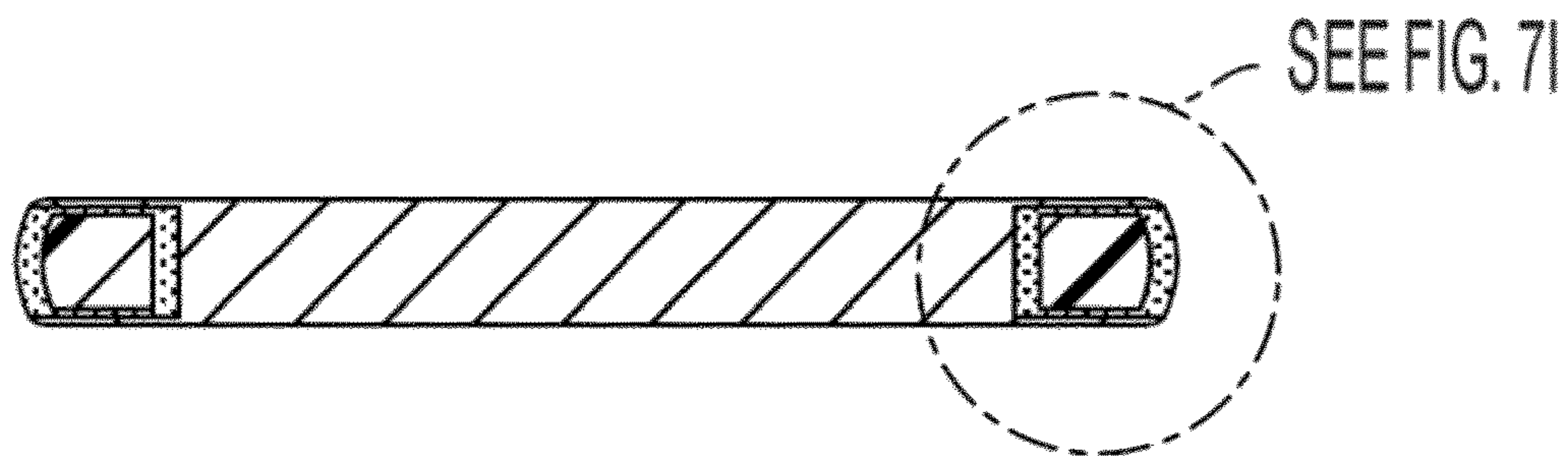

FIG. 7G

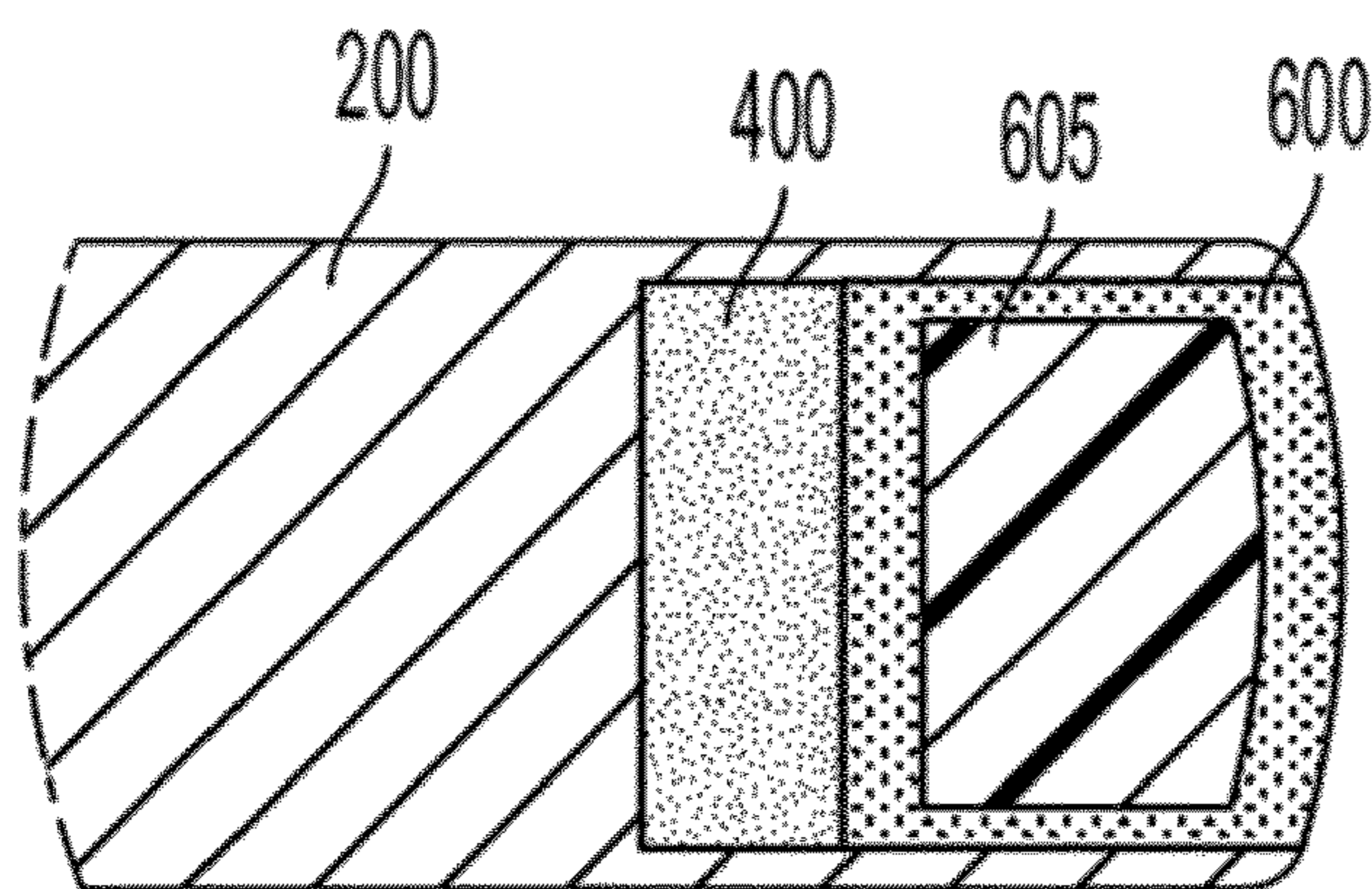

FIG. 7H

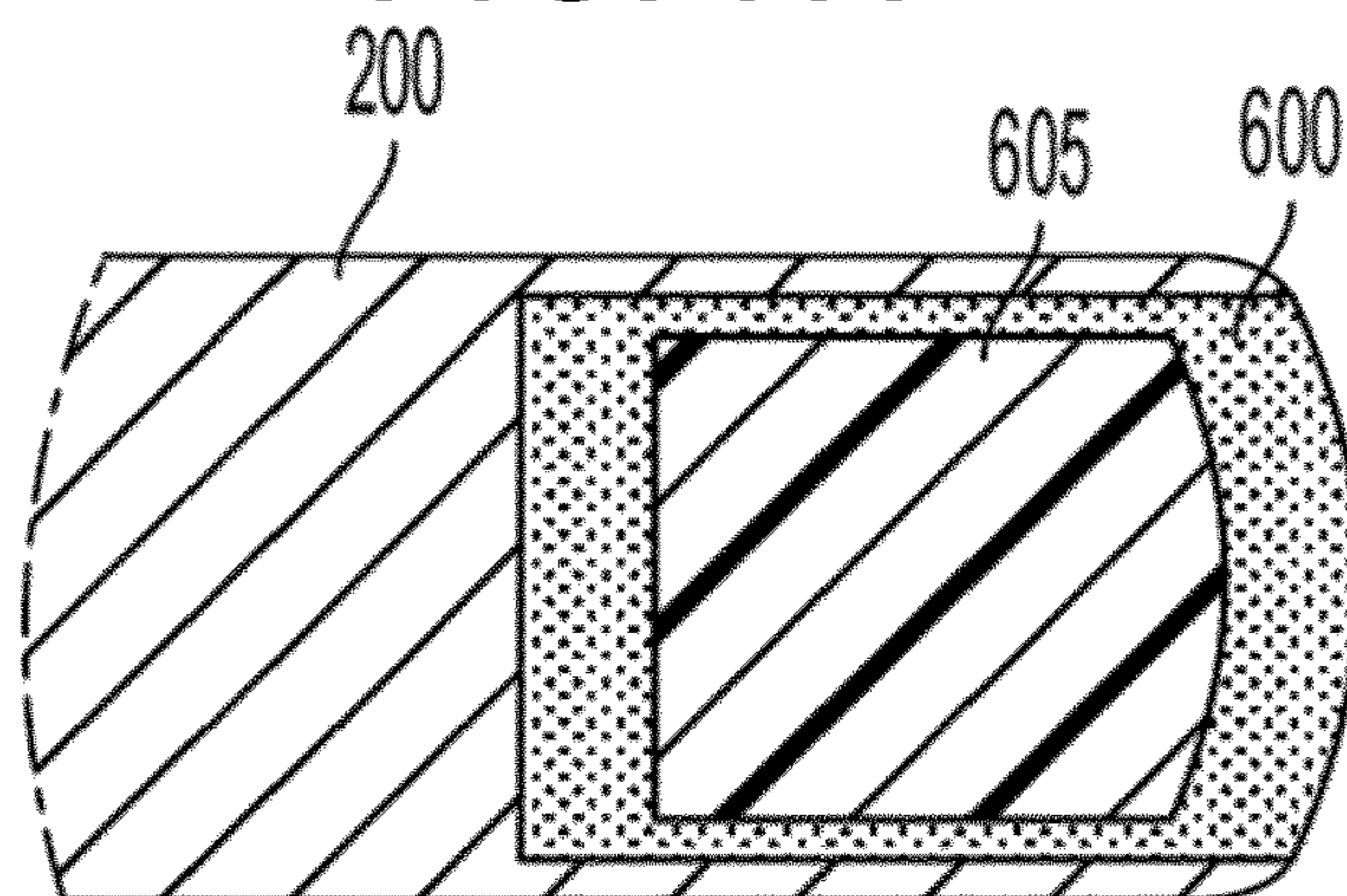

FIG. 7I

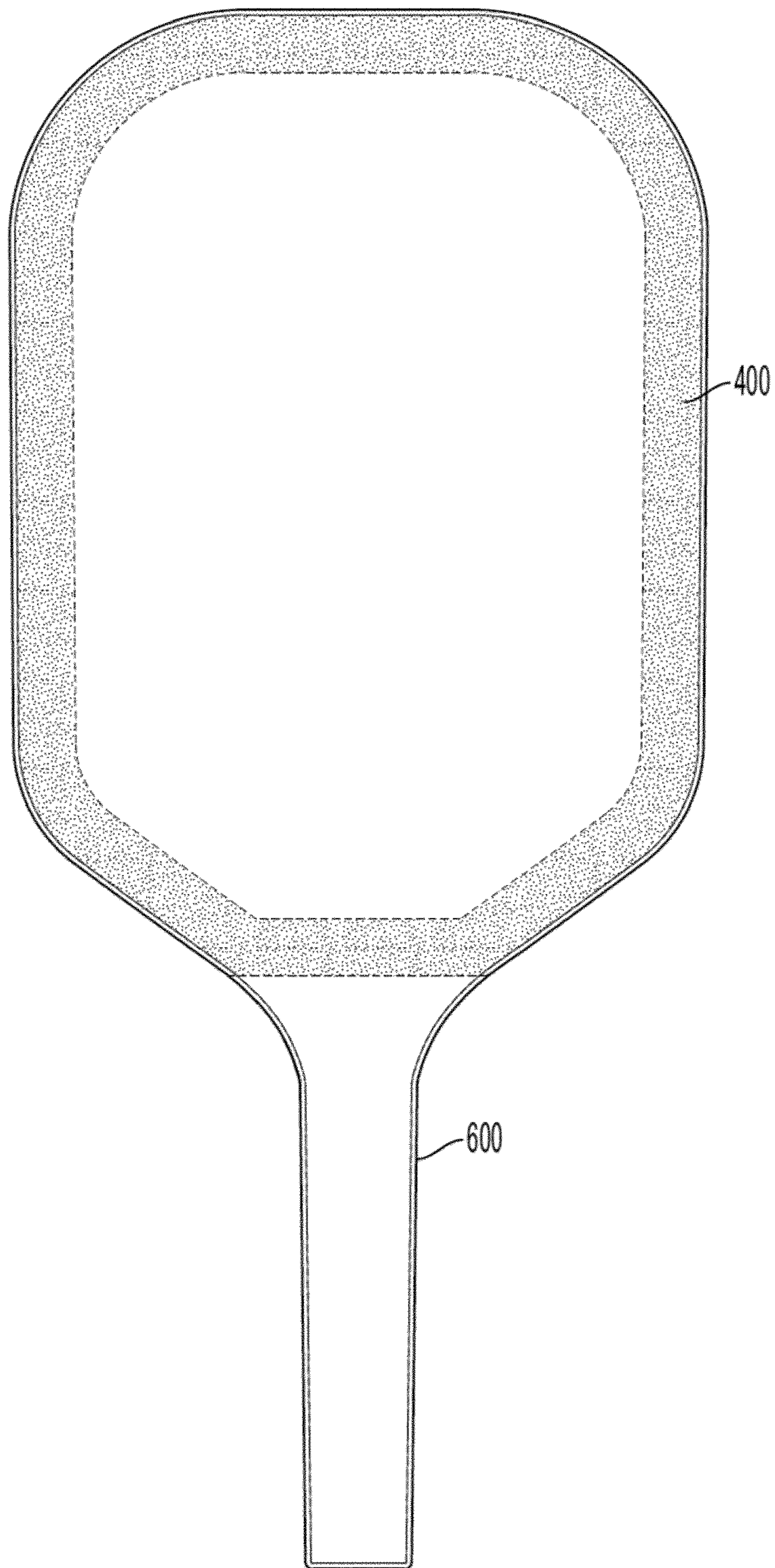

FIG. 8

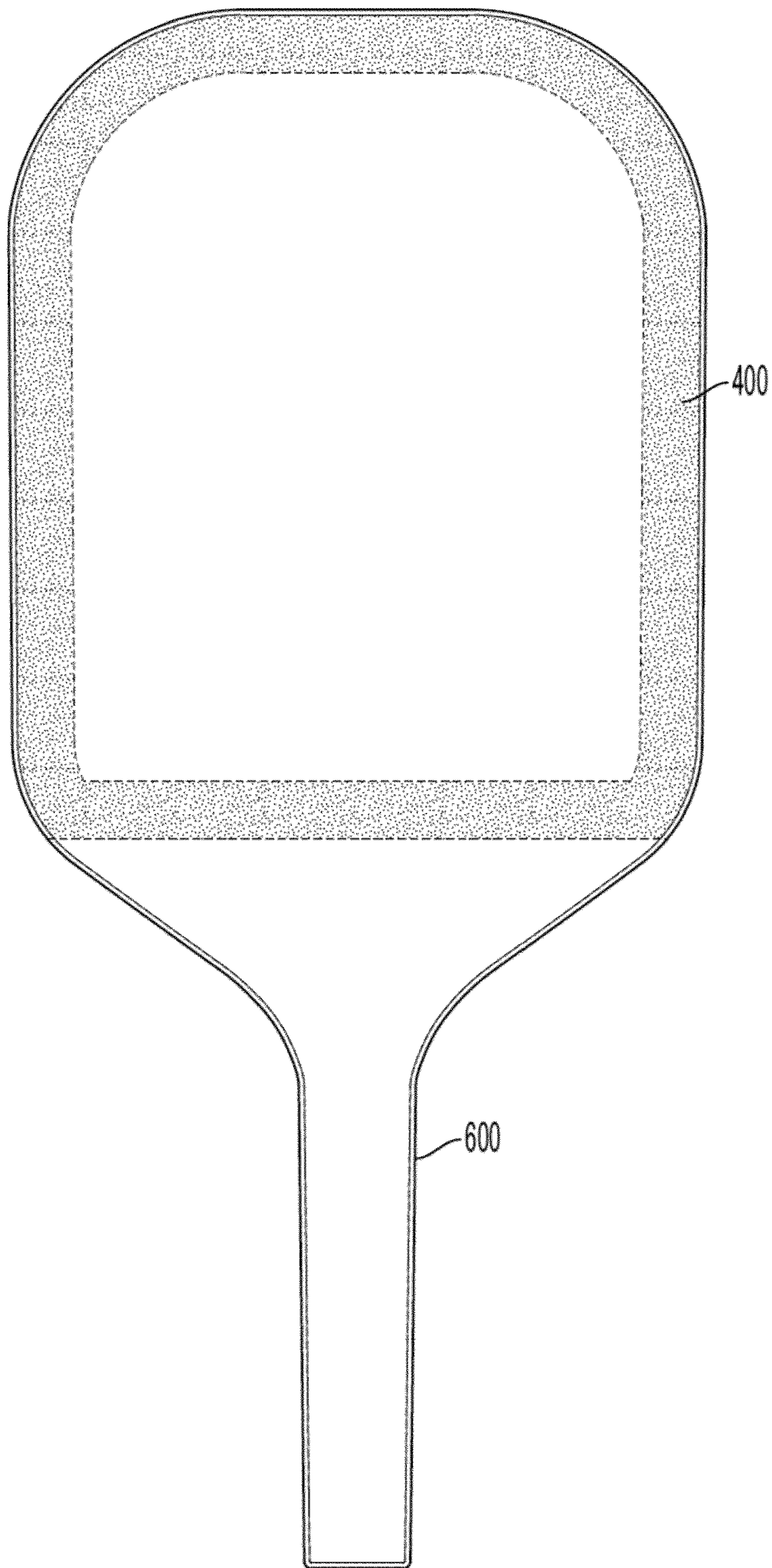

FIG. 9

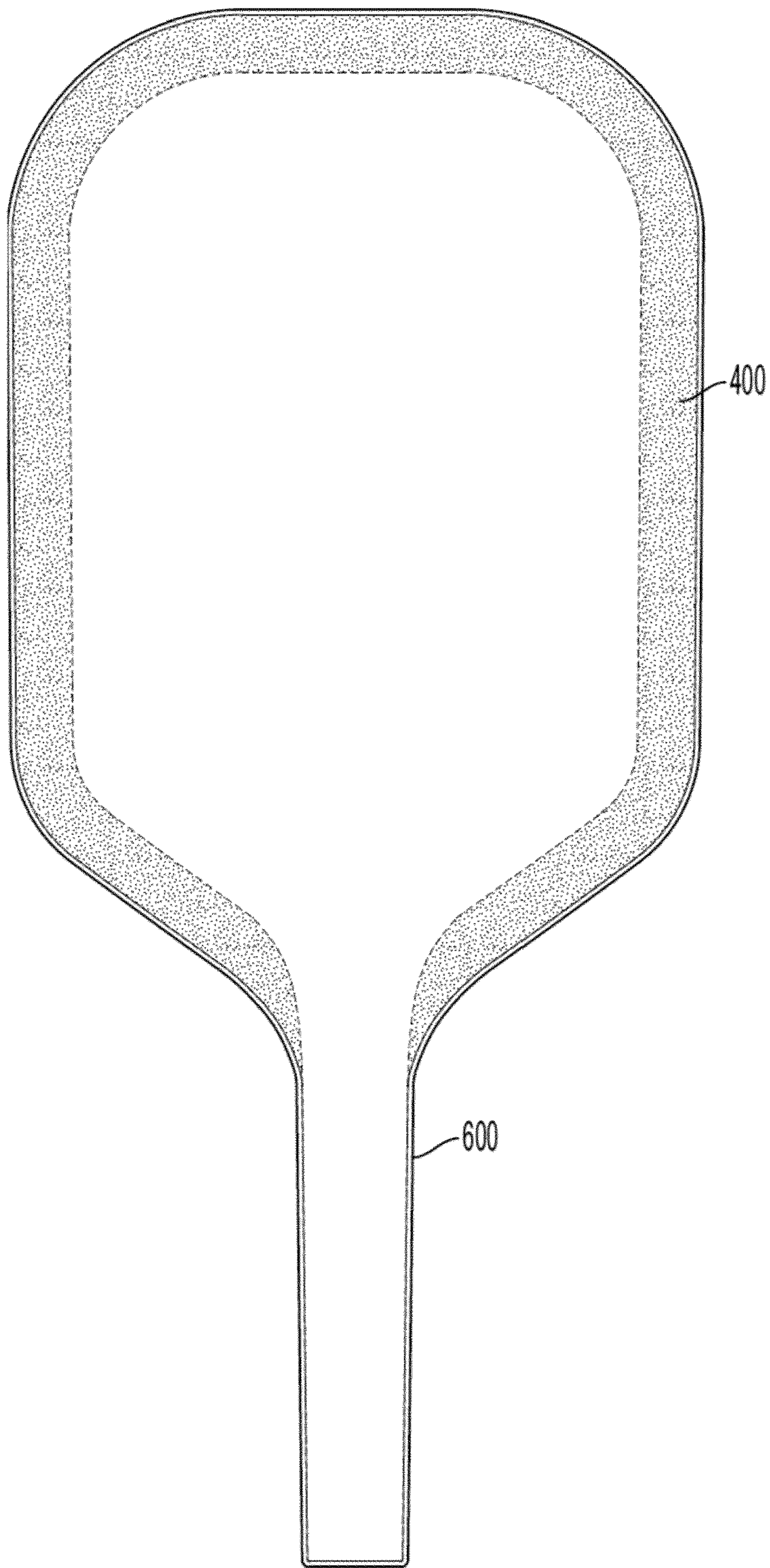

FIG. 10

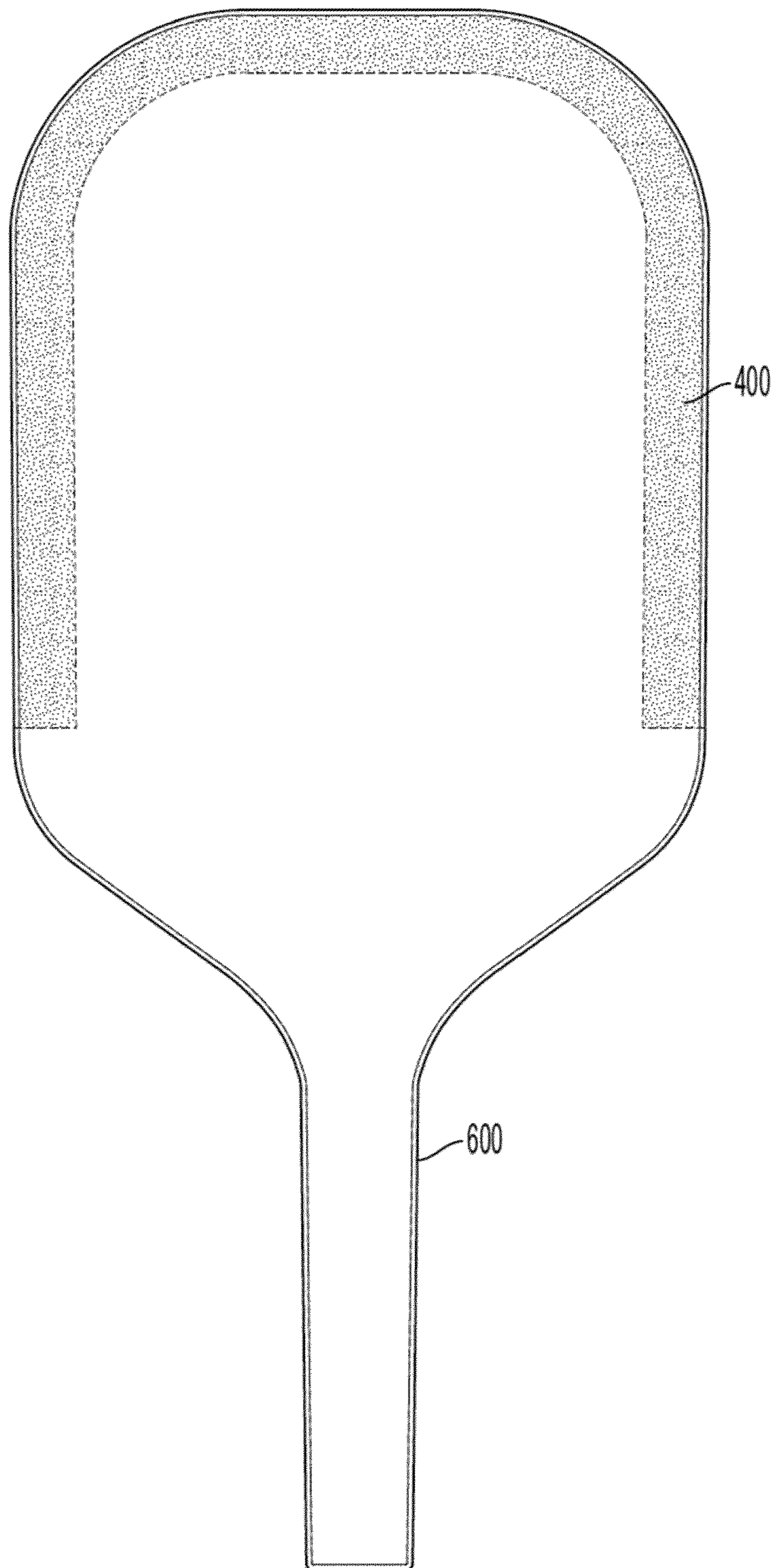

FIG. 11

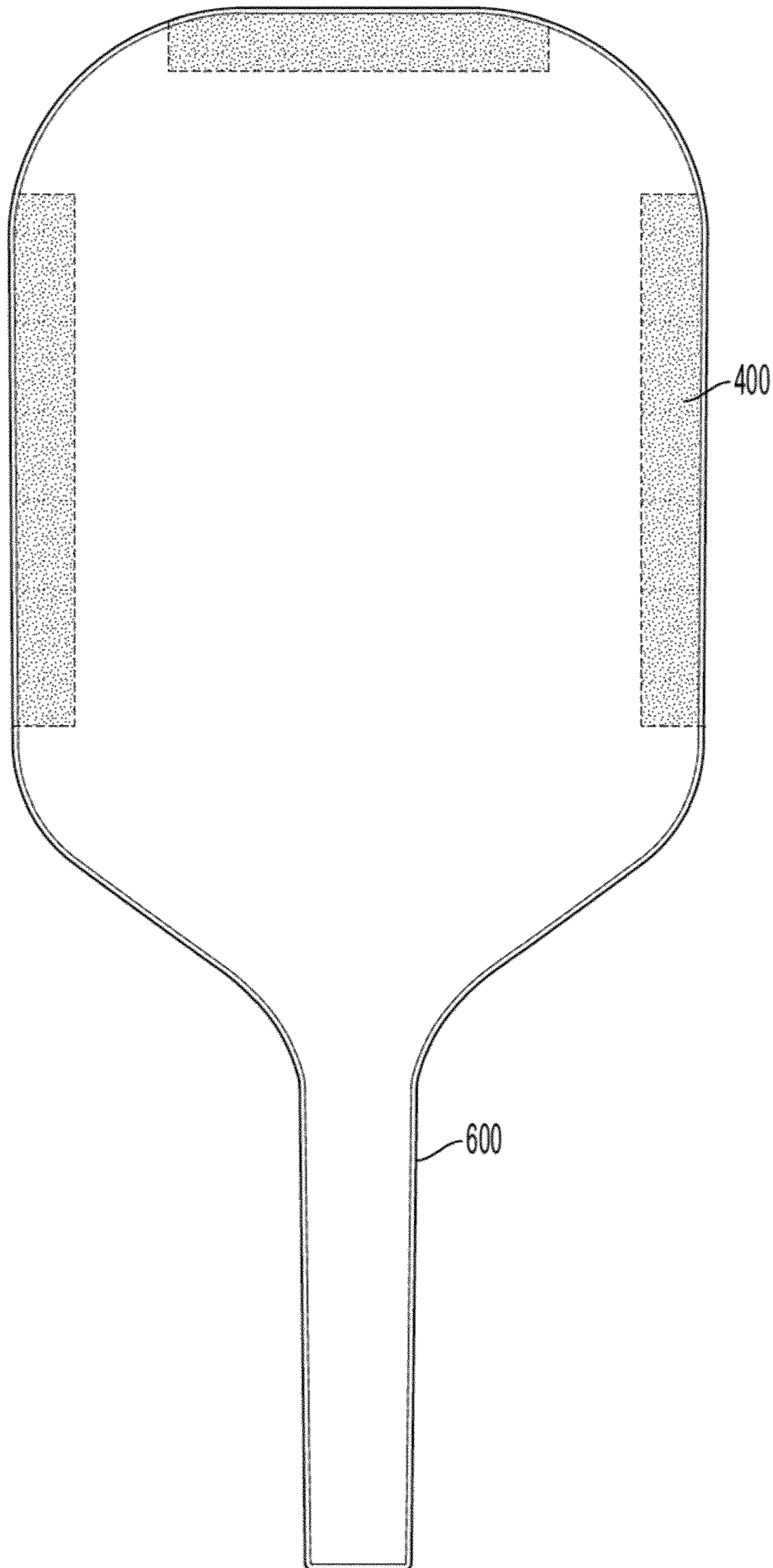

FIG. 12

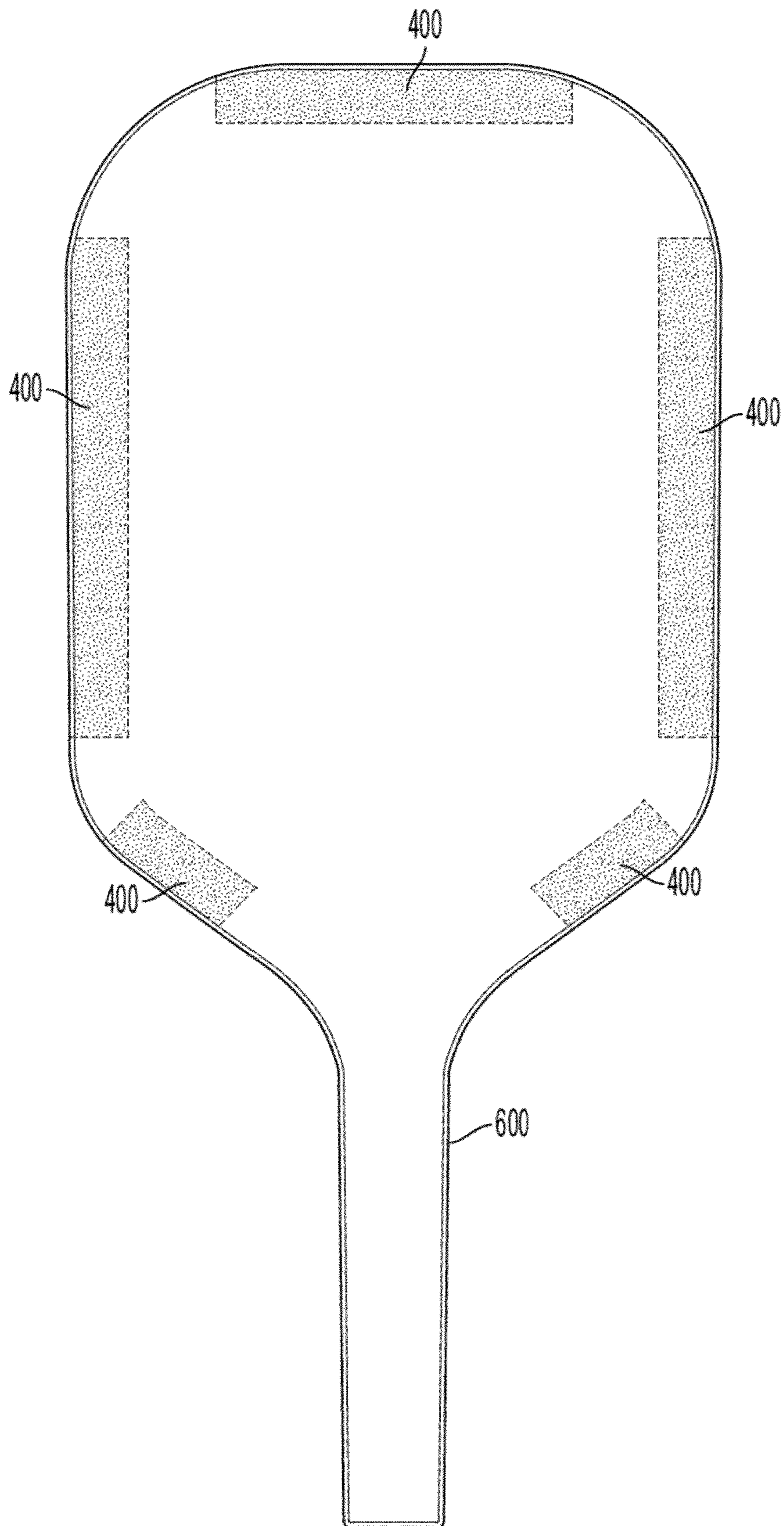

FIG. 13

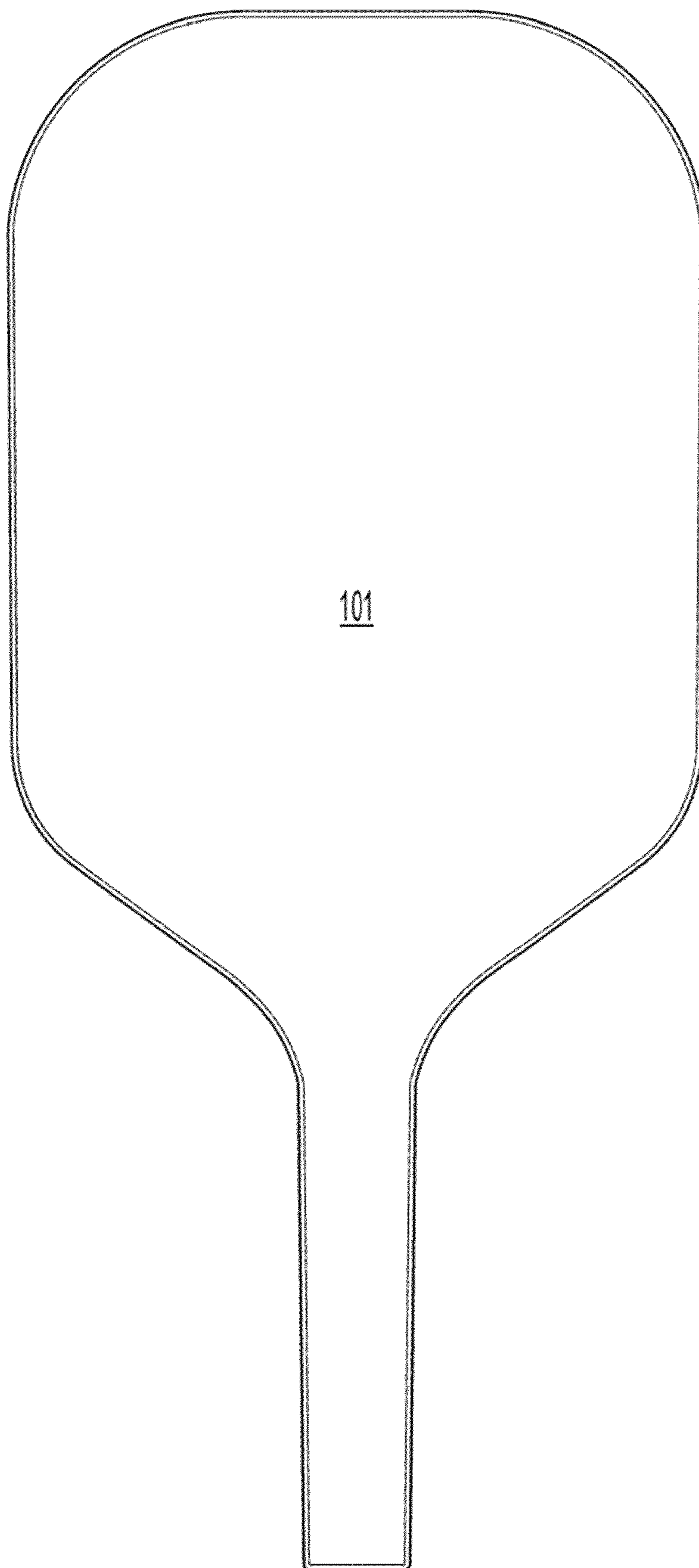

FIG. 14

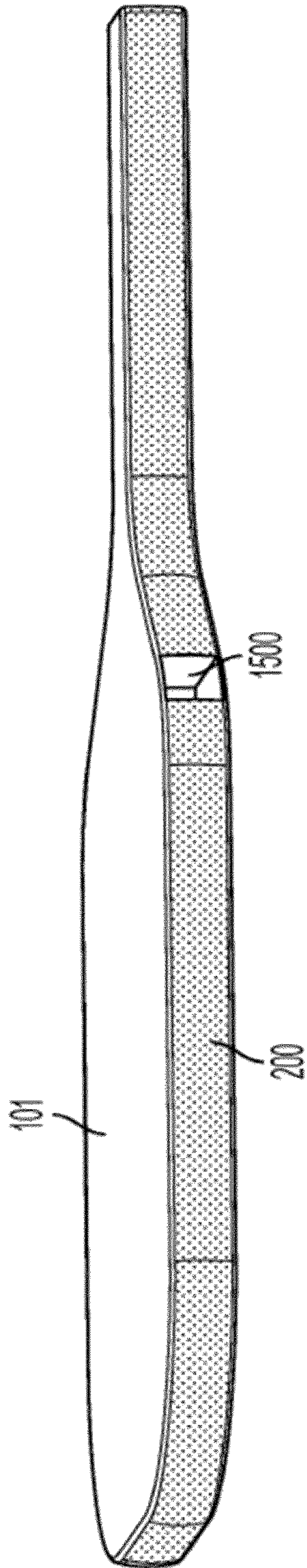

FIG. 15

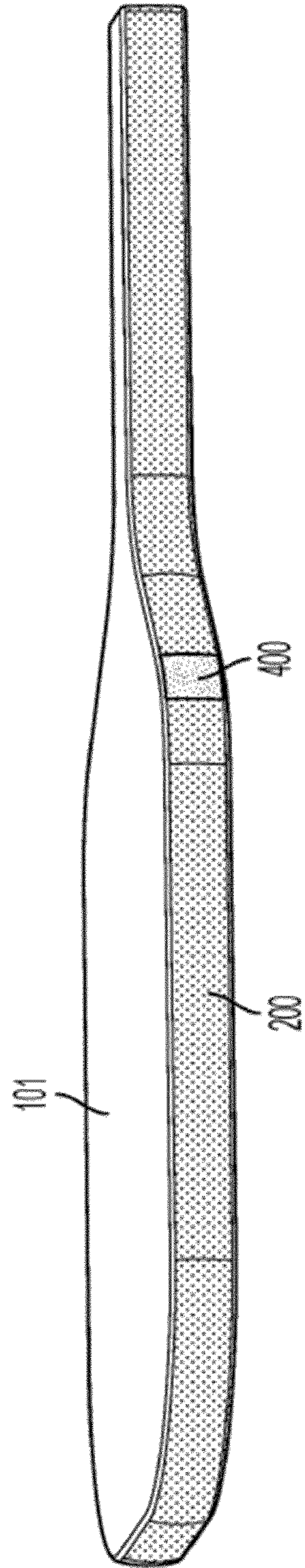

FIG. 16

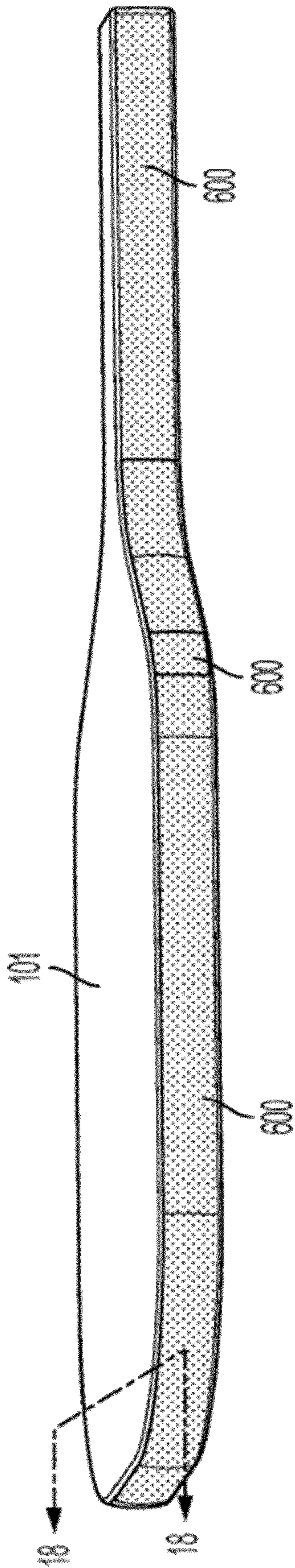

FIG. 17

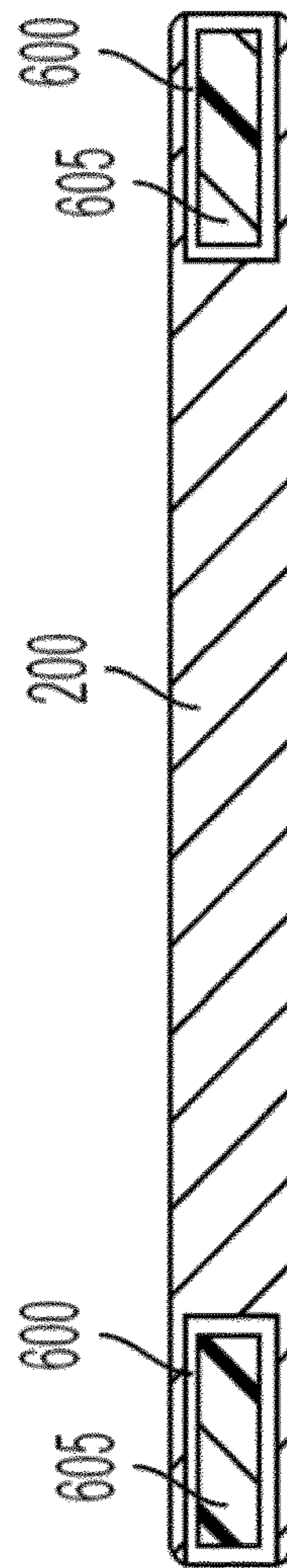

FIG. 18

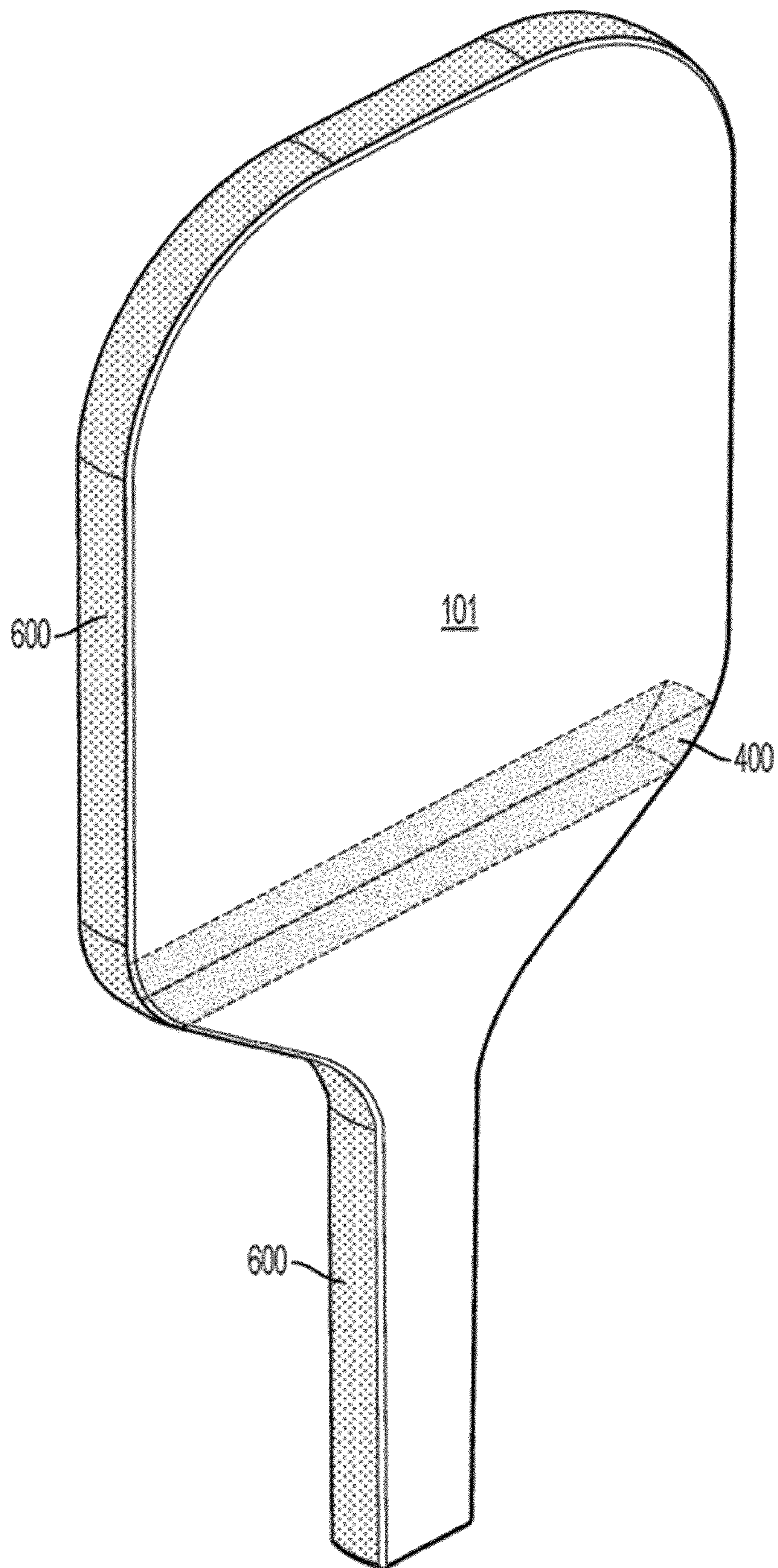

FIG. 19

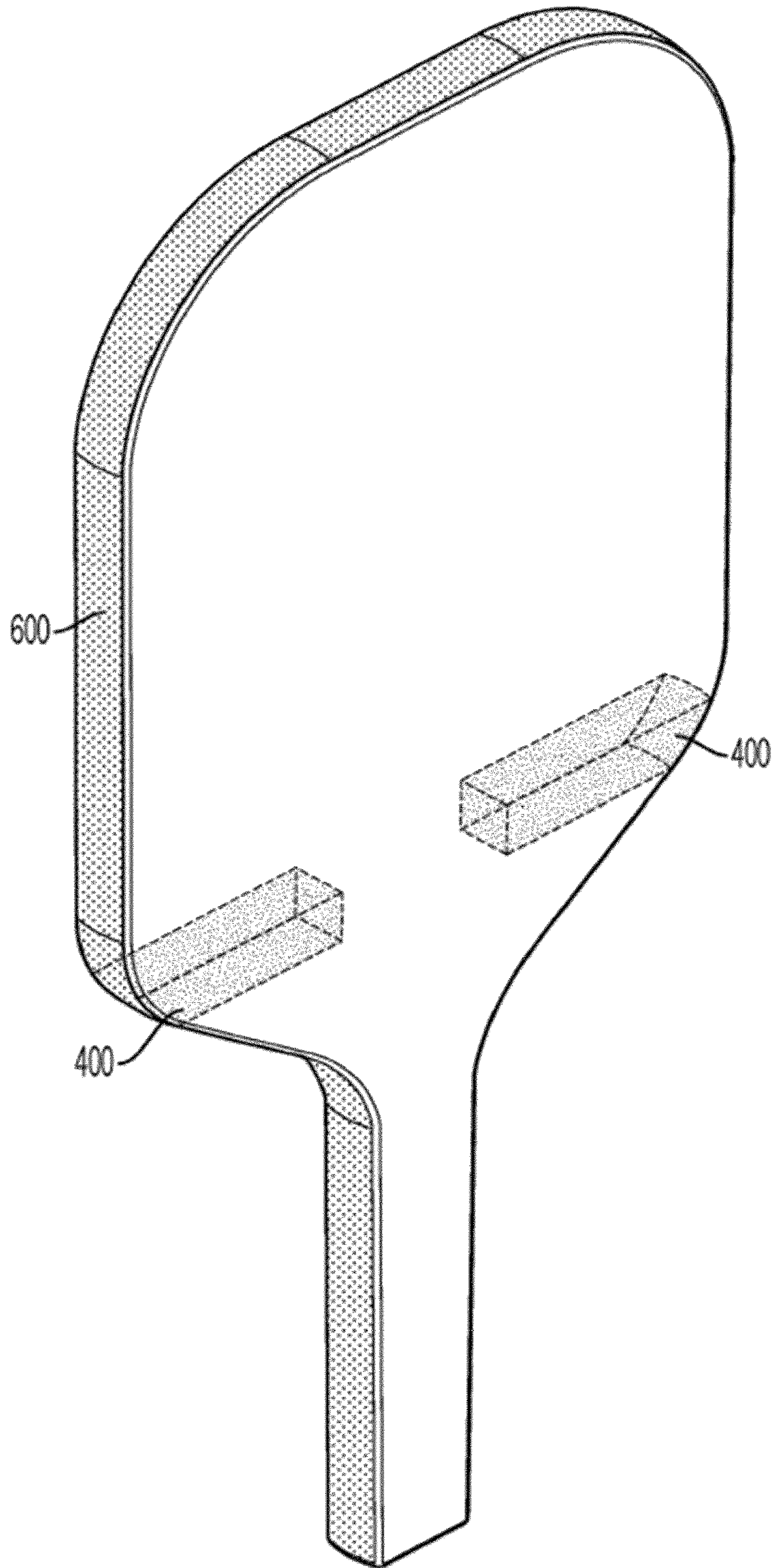

FIG. 20

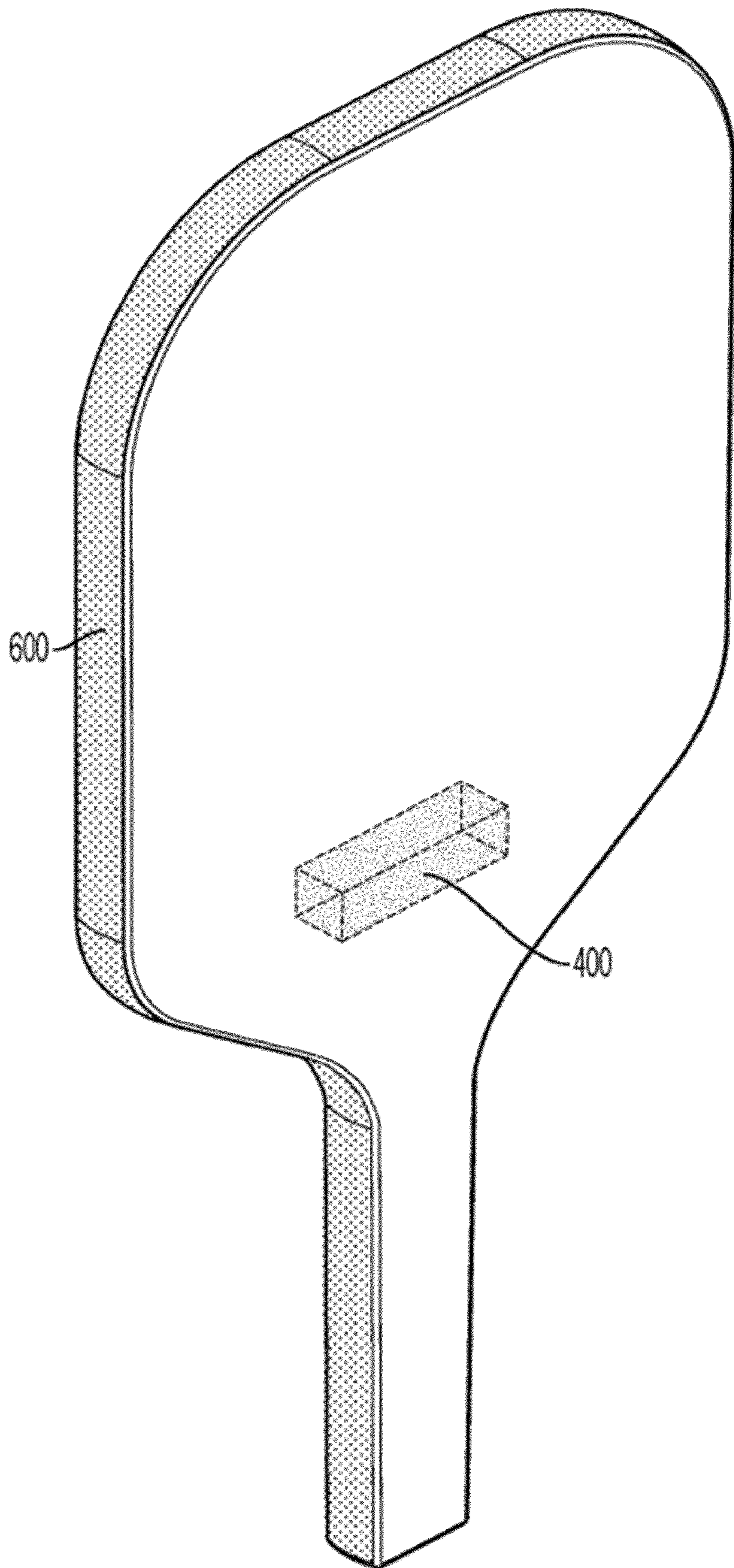

FIG. 21

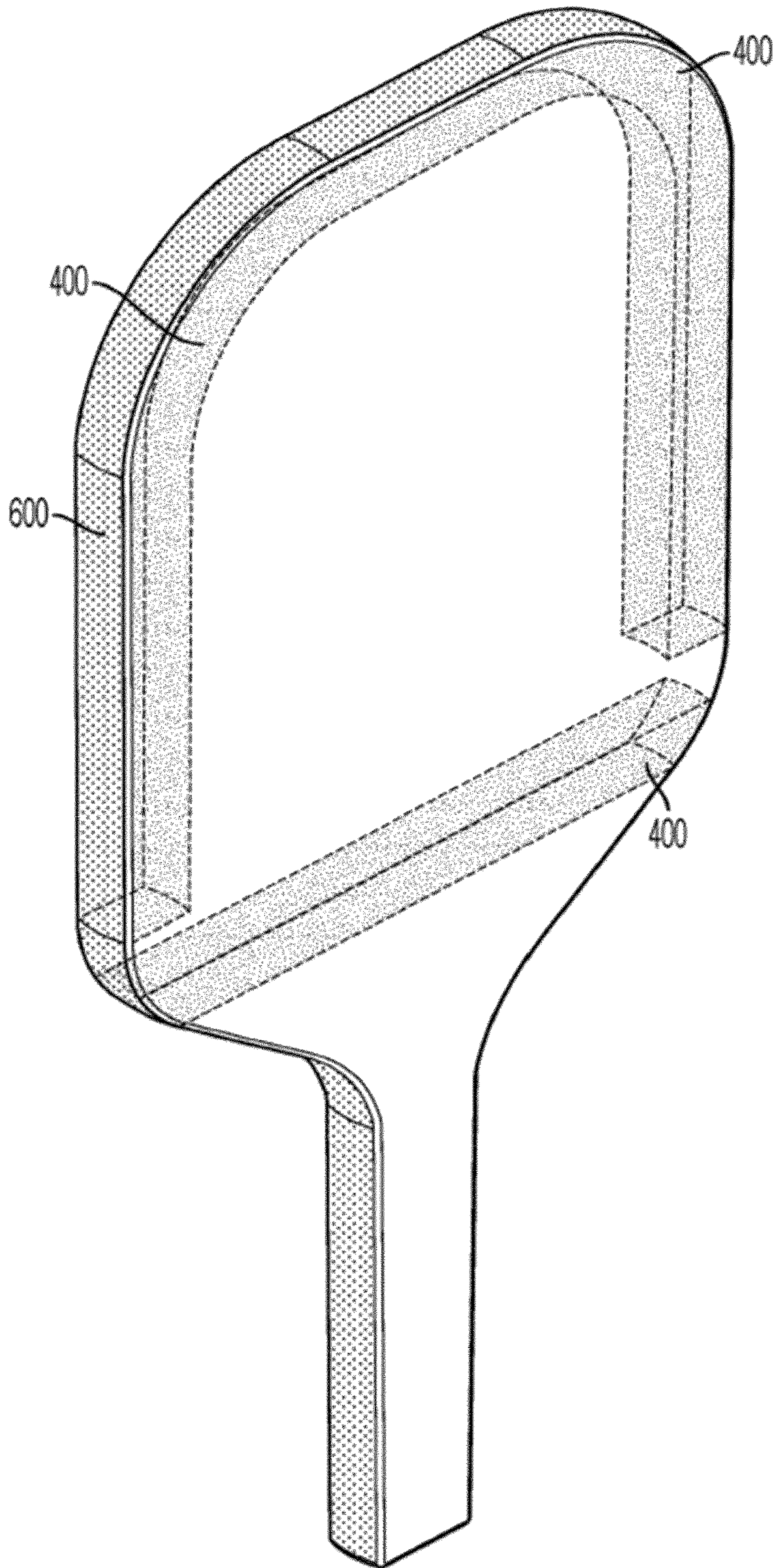

FIG. 22

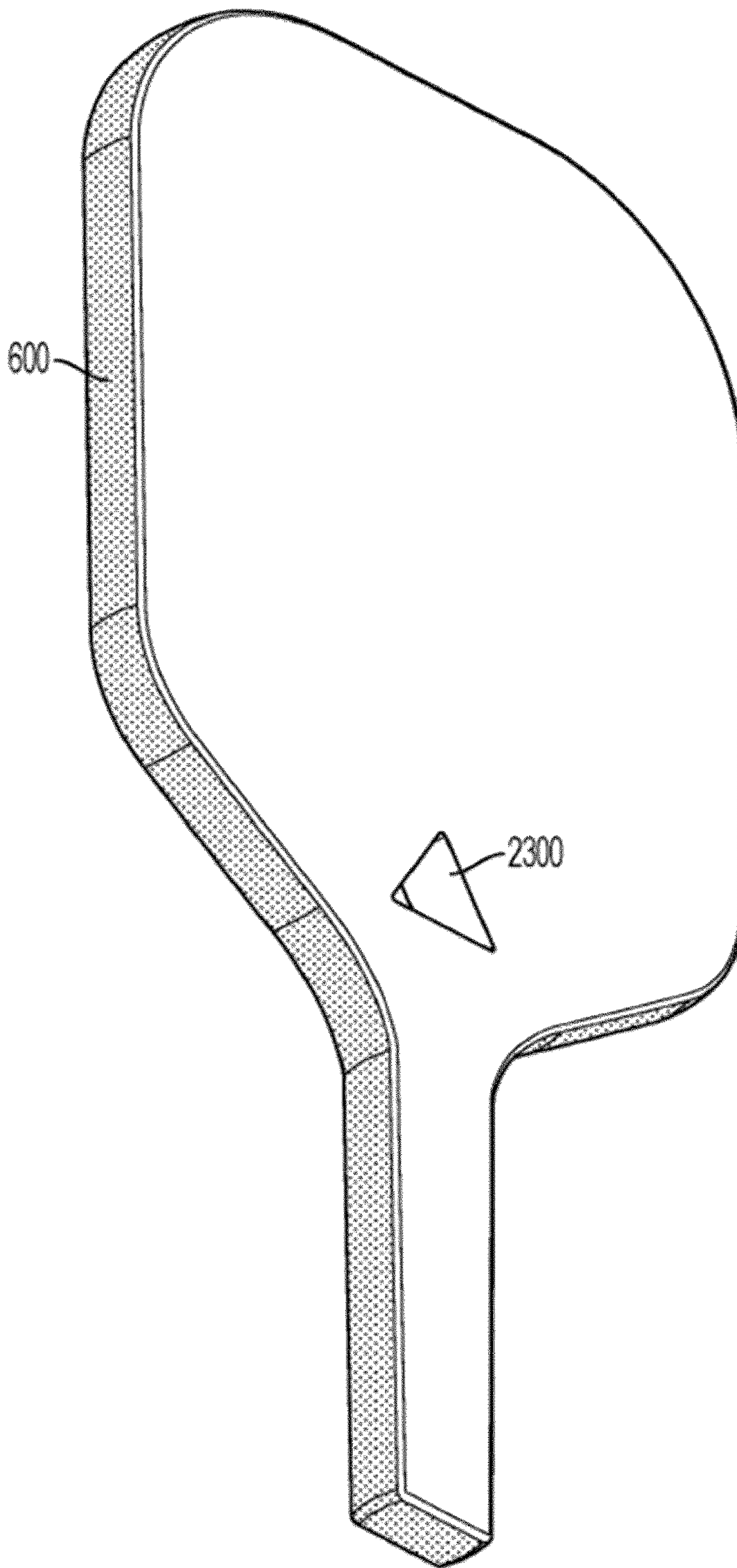

FIG. 23

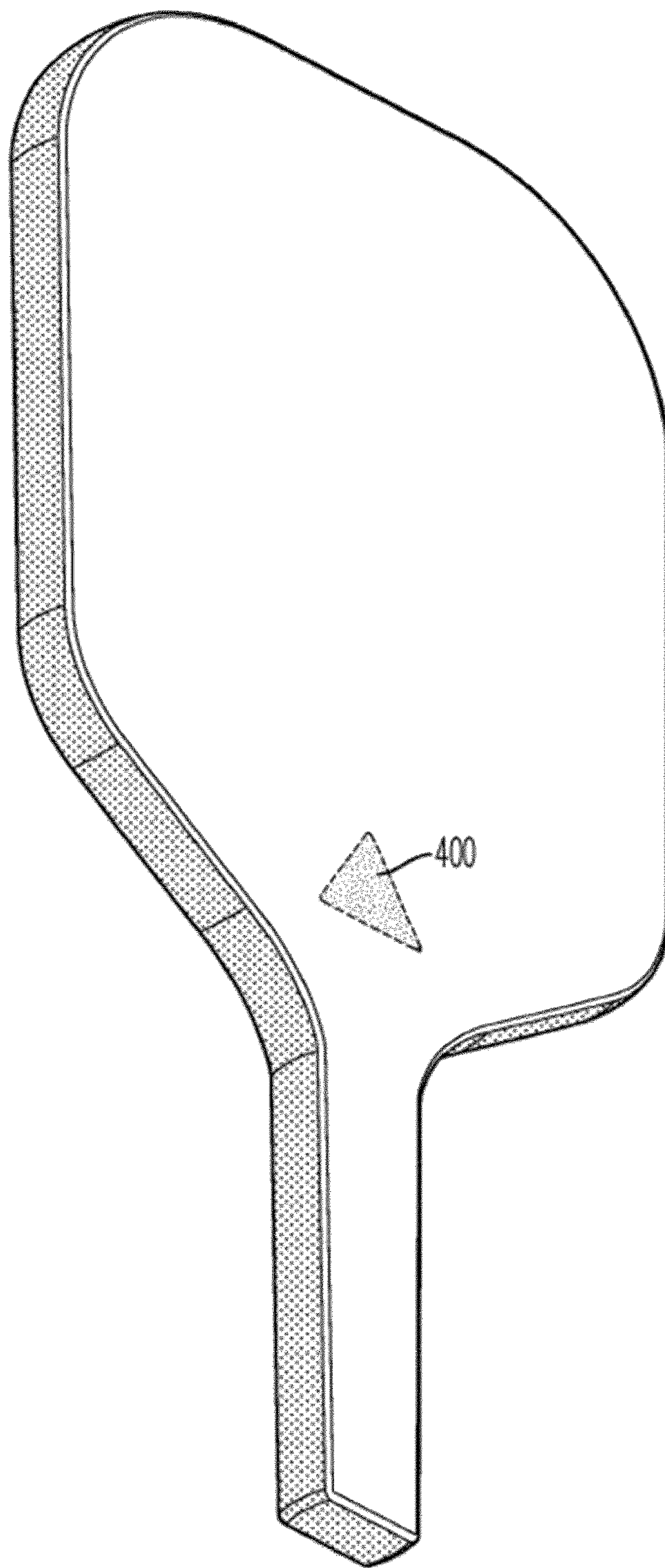

FIG. 24

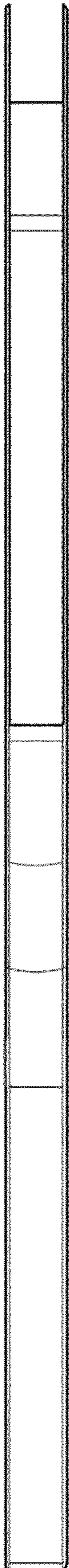

FIG. 25

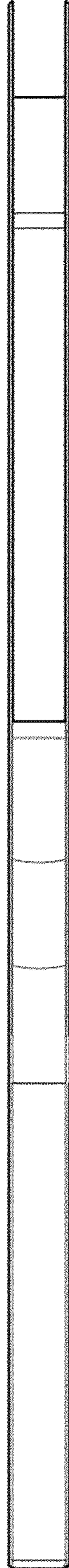

FIG. 26

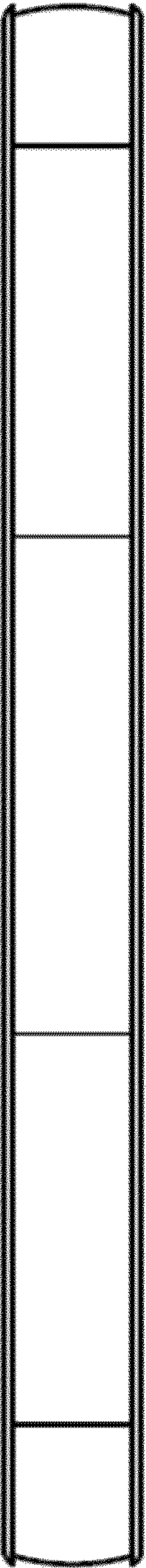

FIG. 27

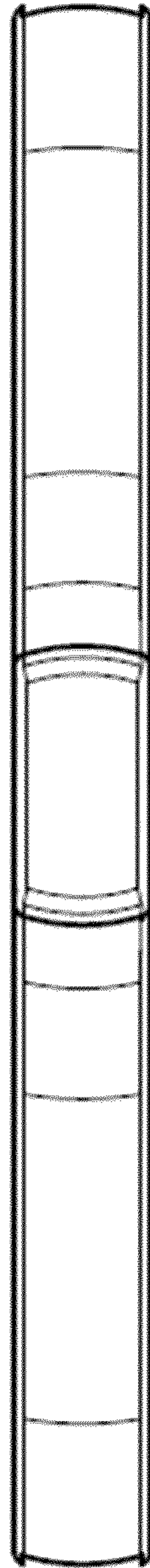

FIG. 28

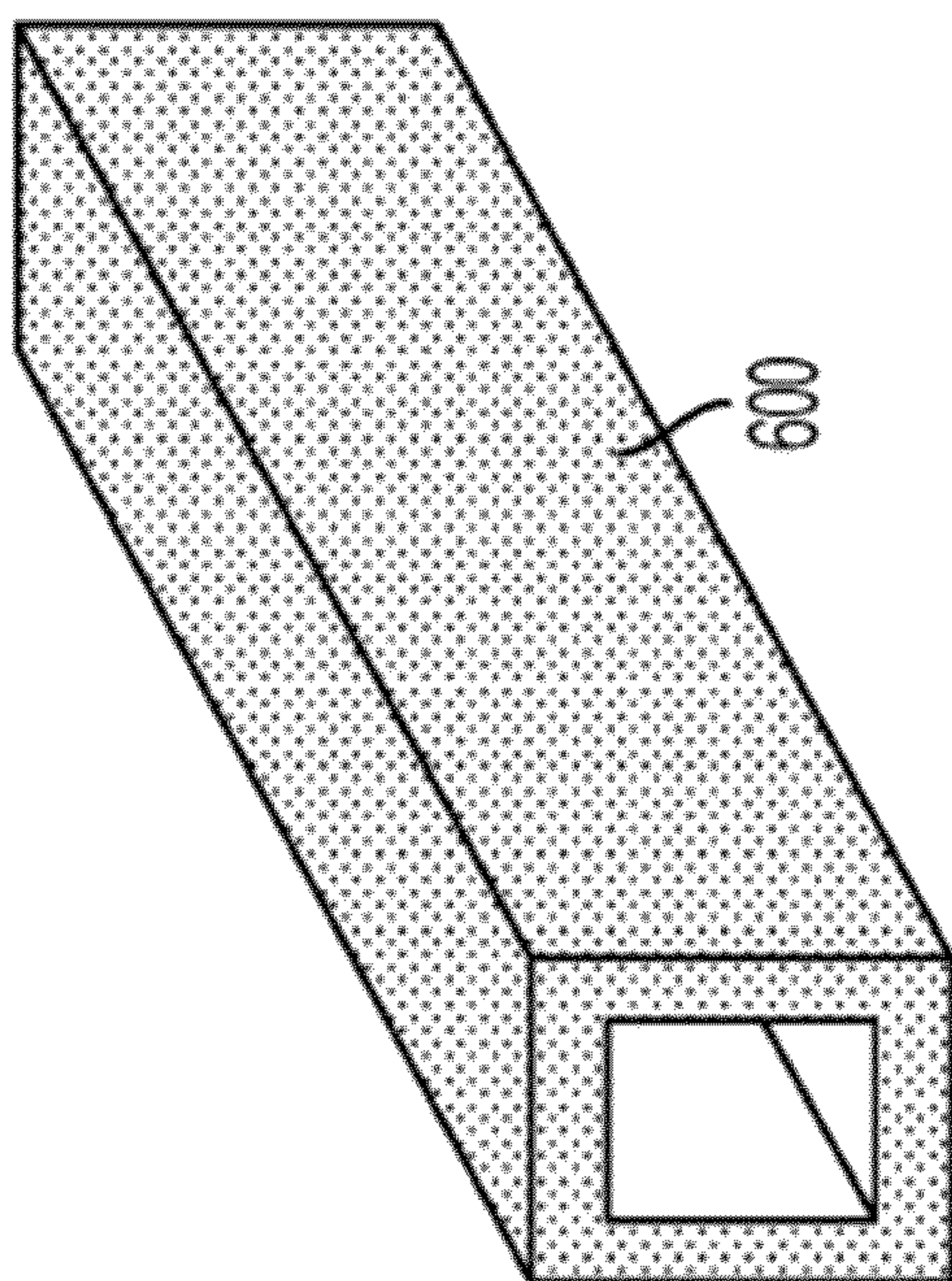

FIG. 29

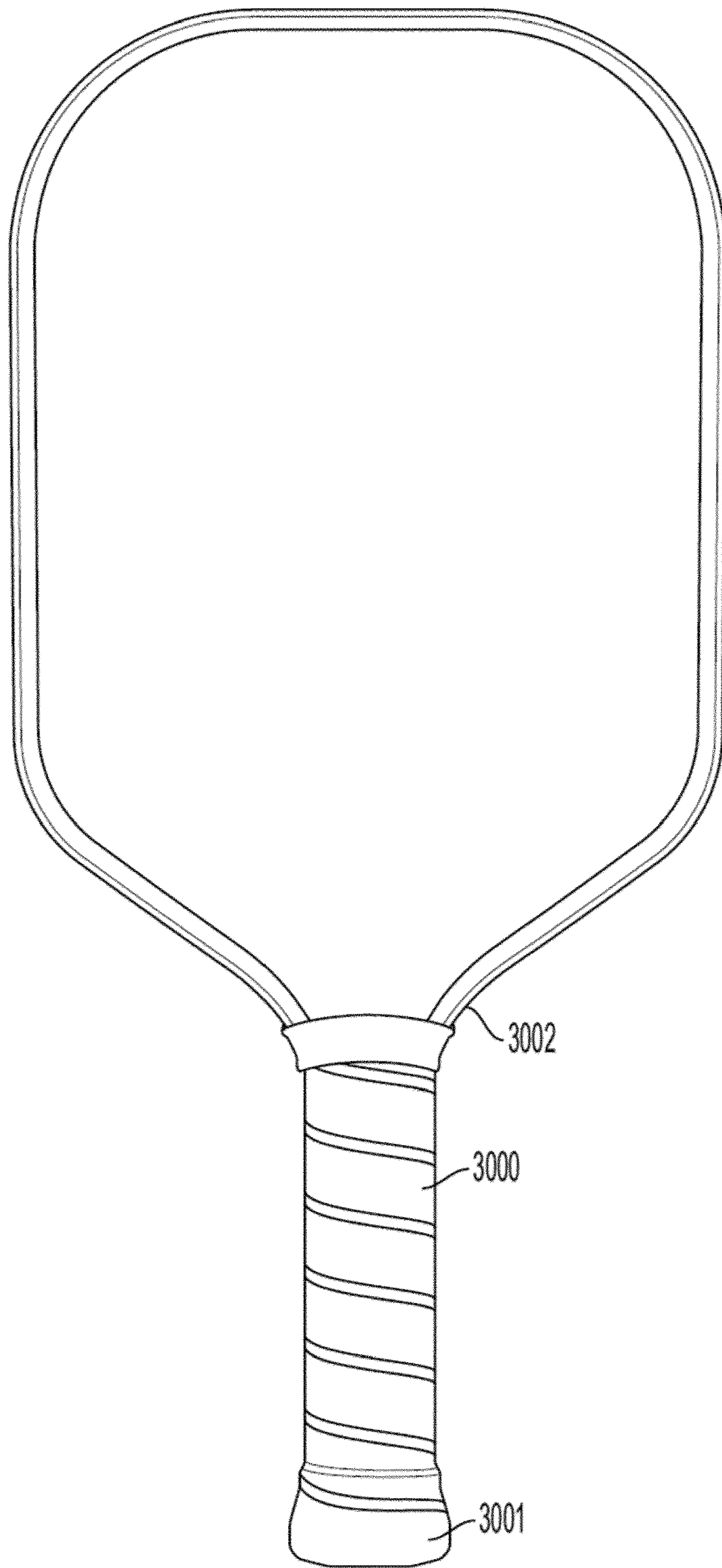

FIG. 30

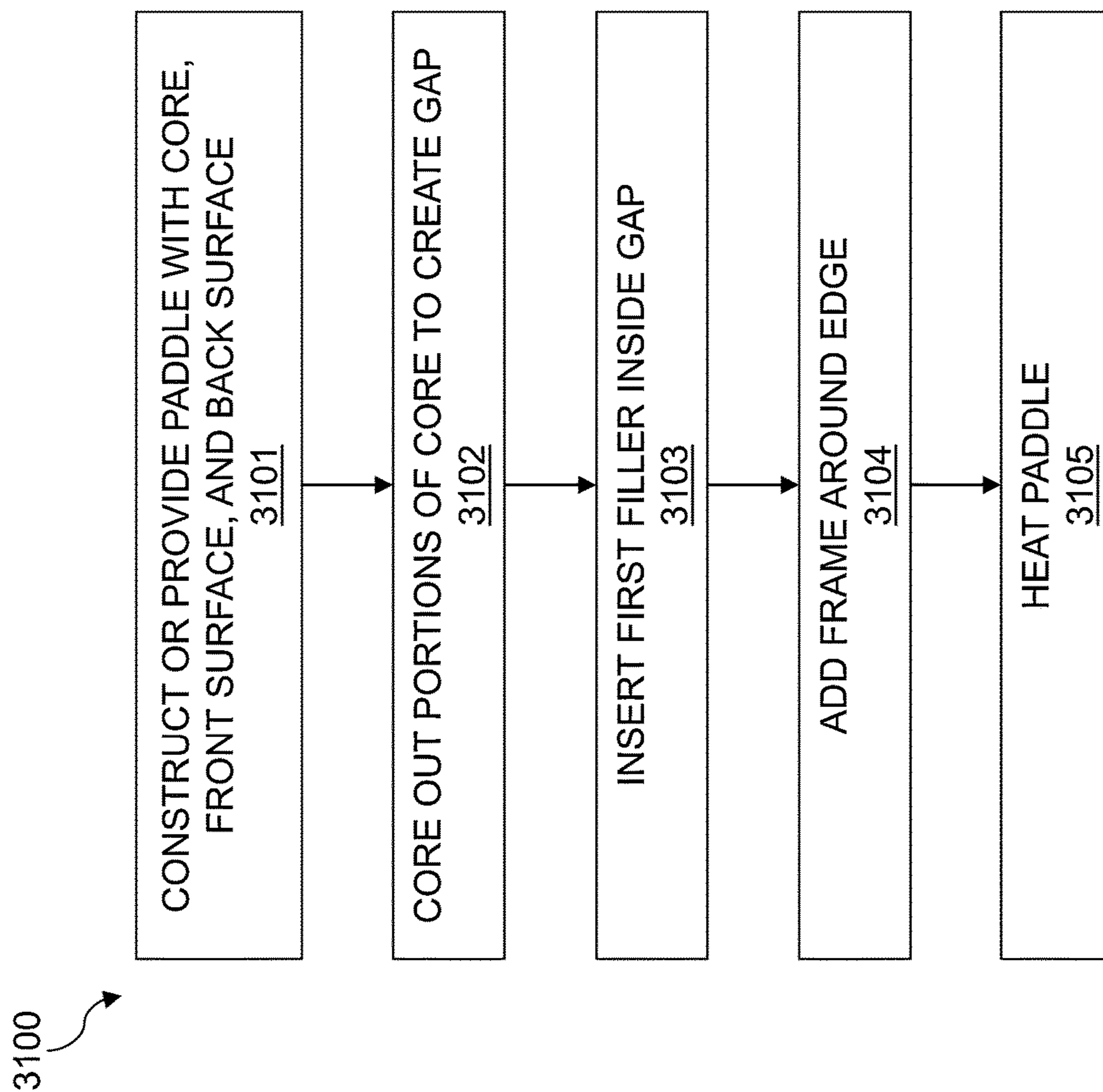

FIG. 31

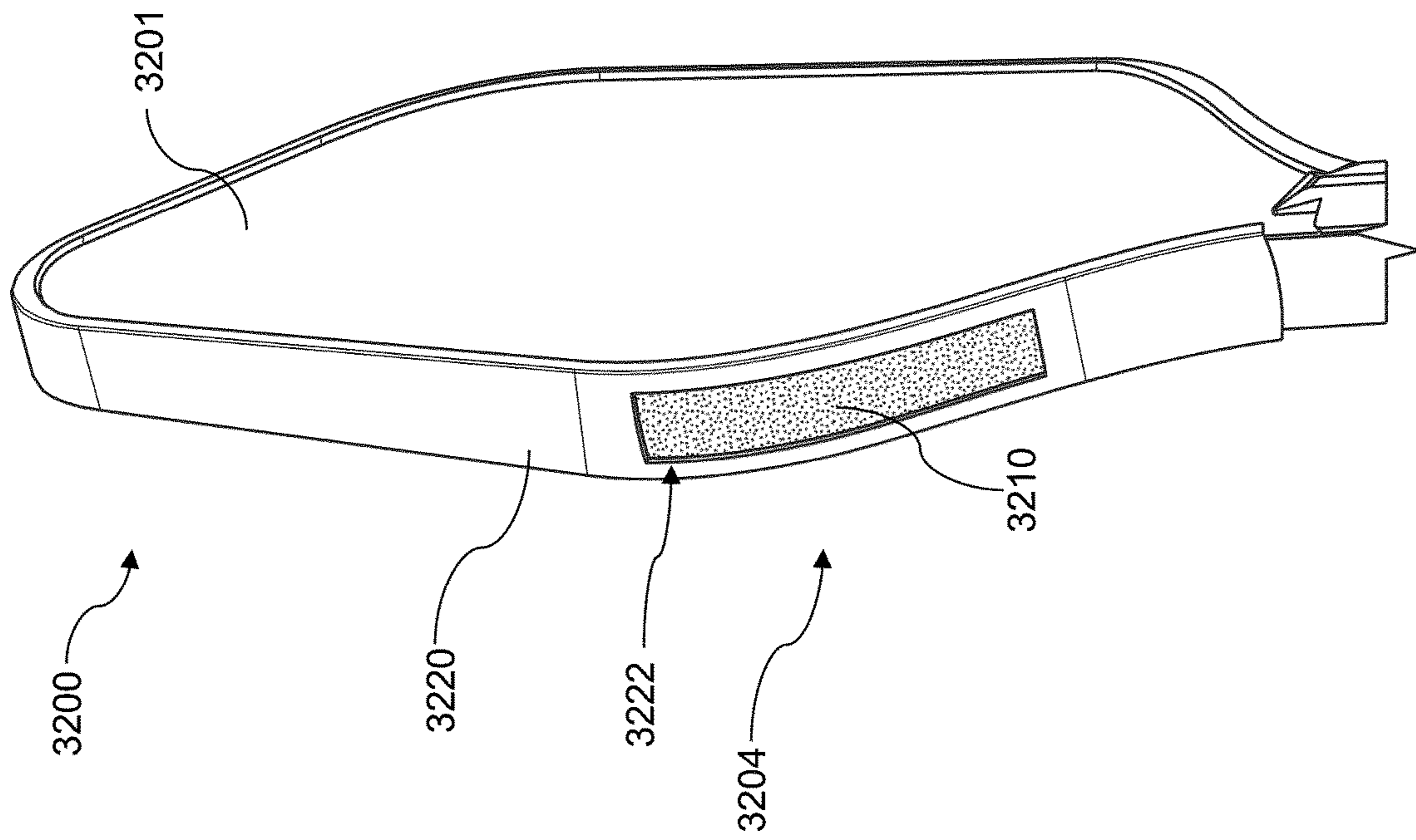

FIG. 32

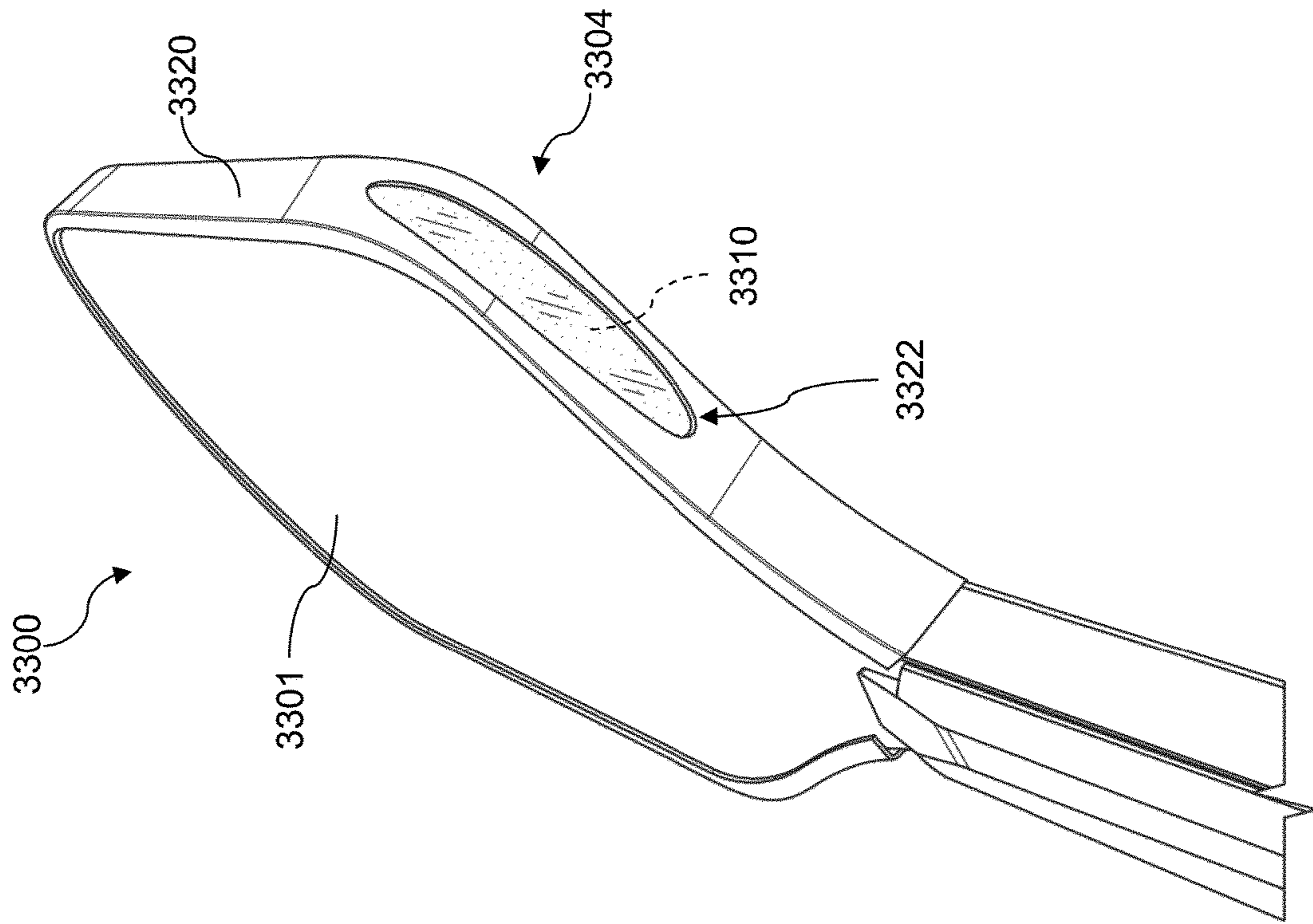

FIG. 33

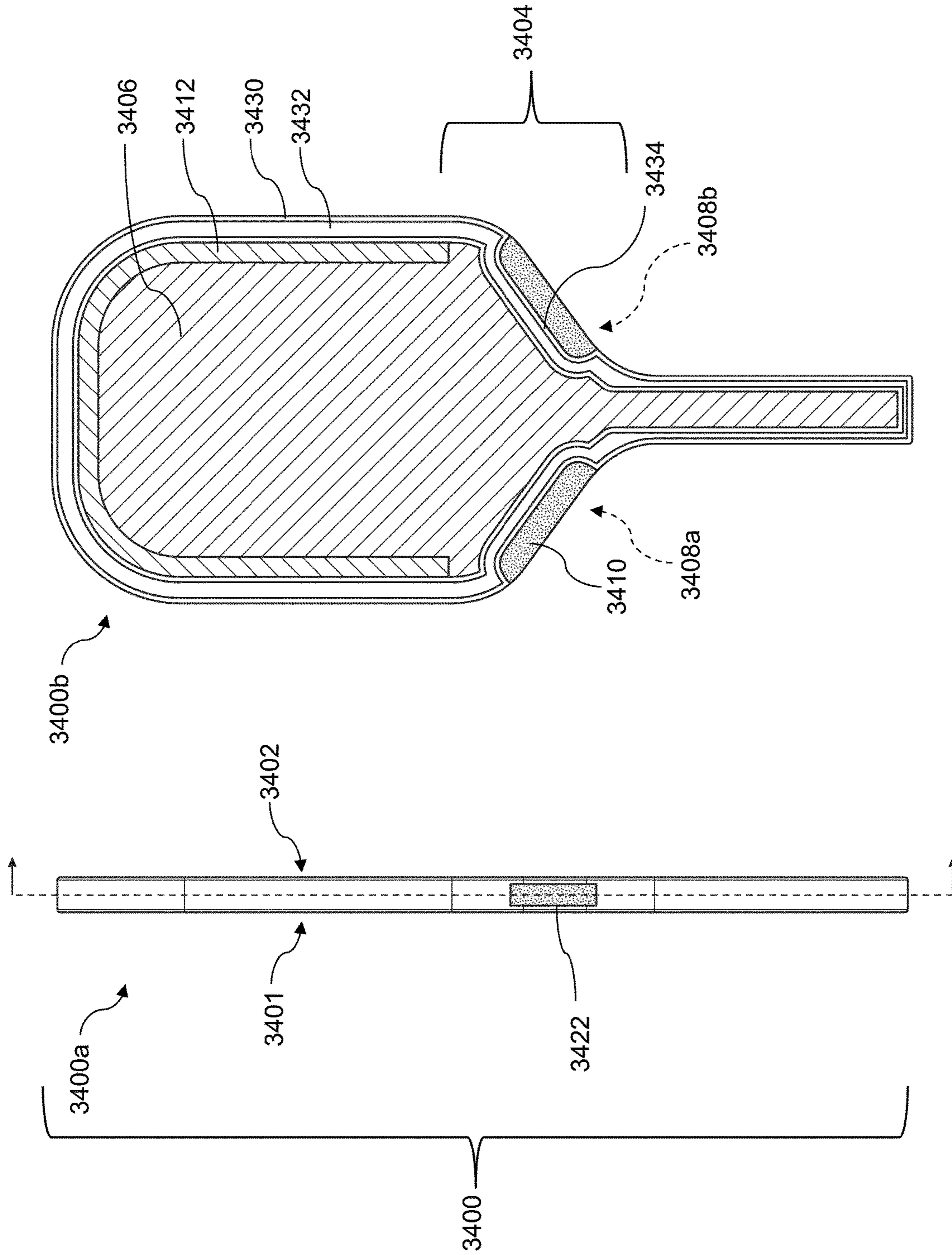

FIG. 34

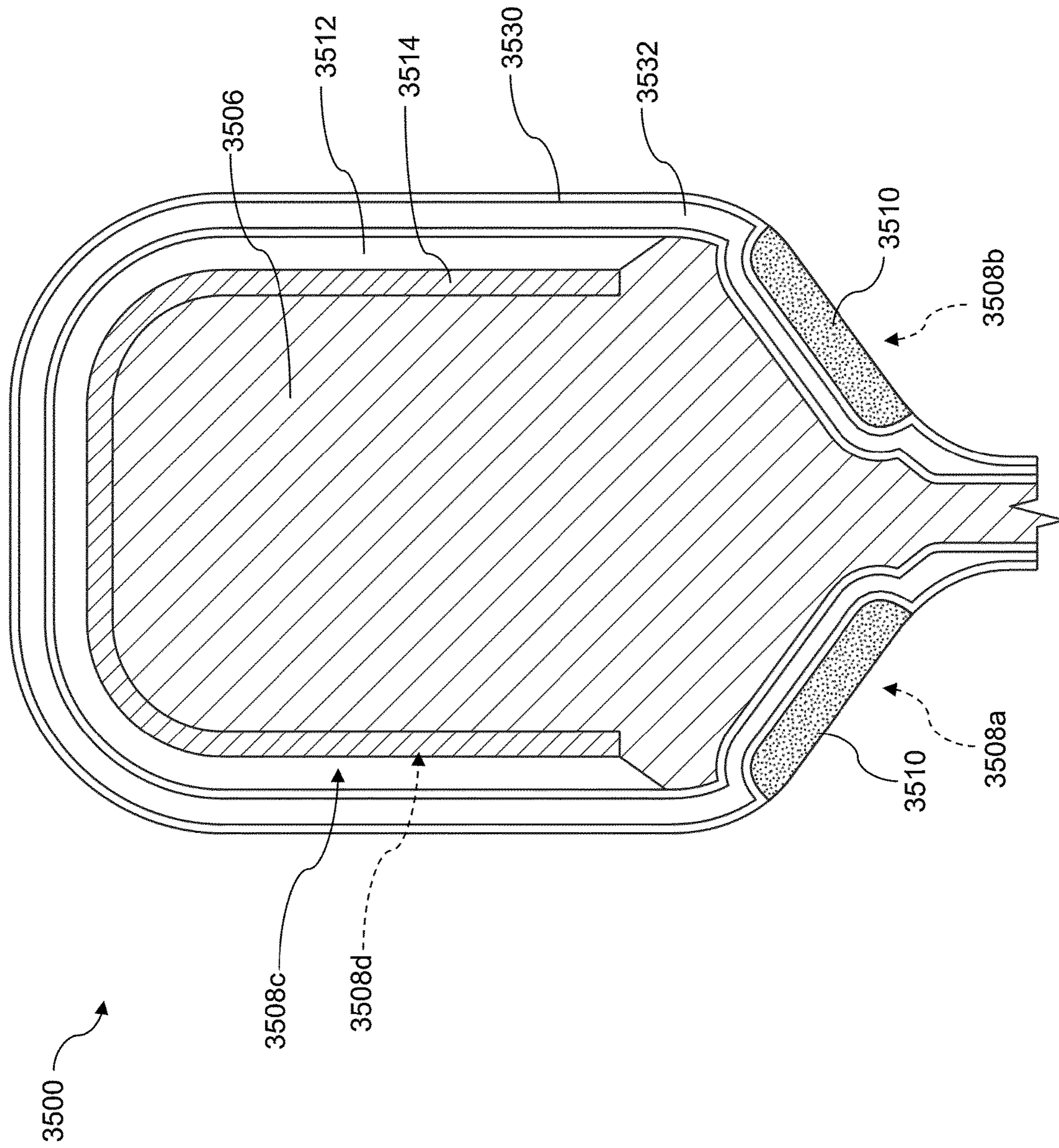

FIG. 35

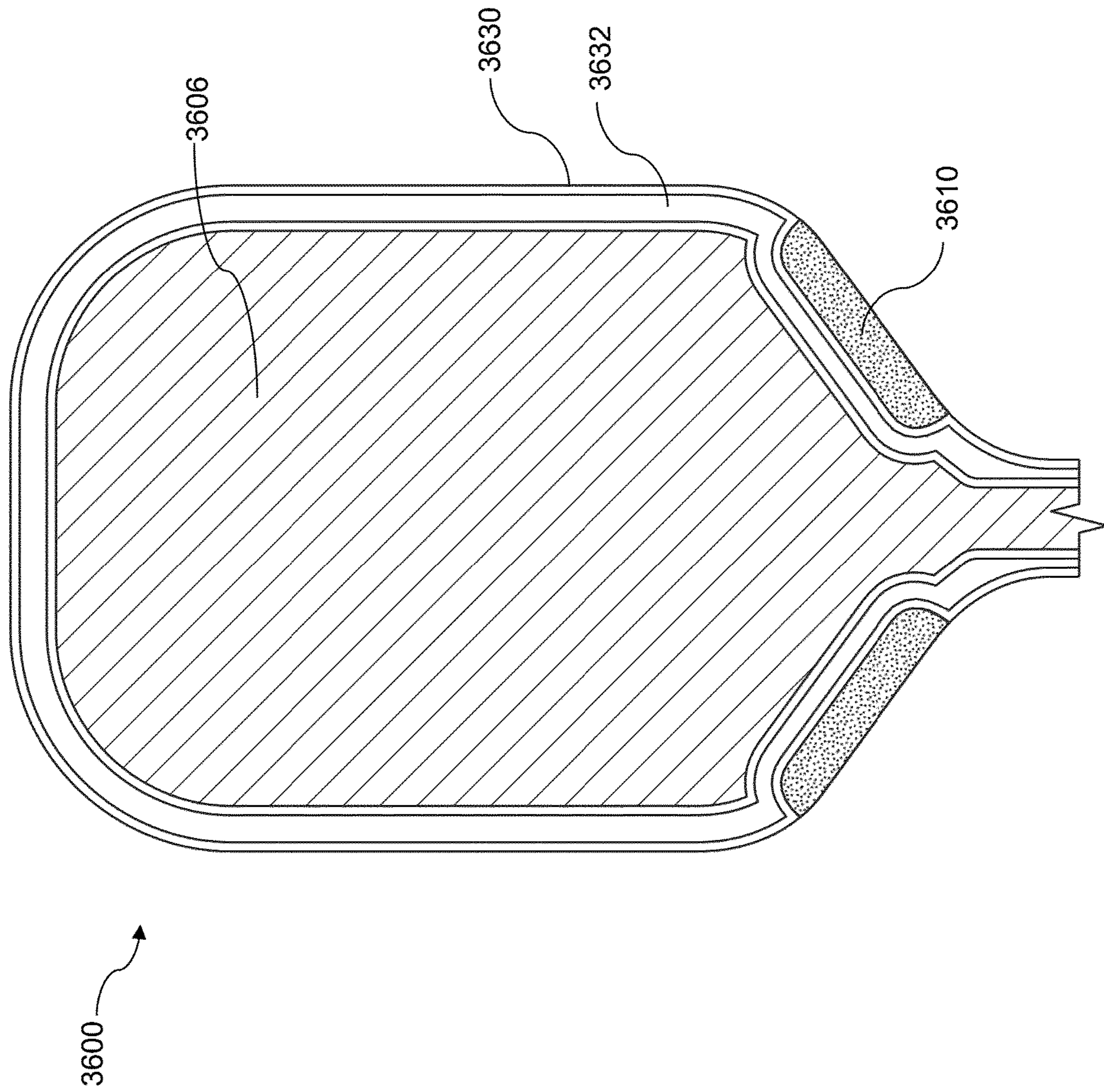

FIG. 36

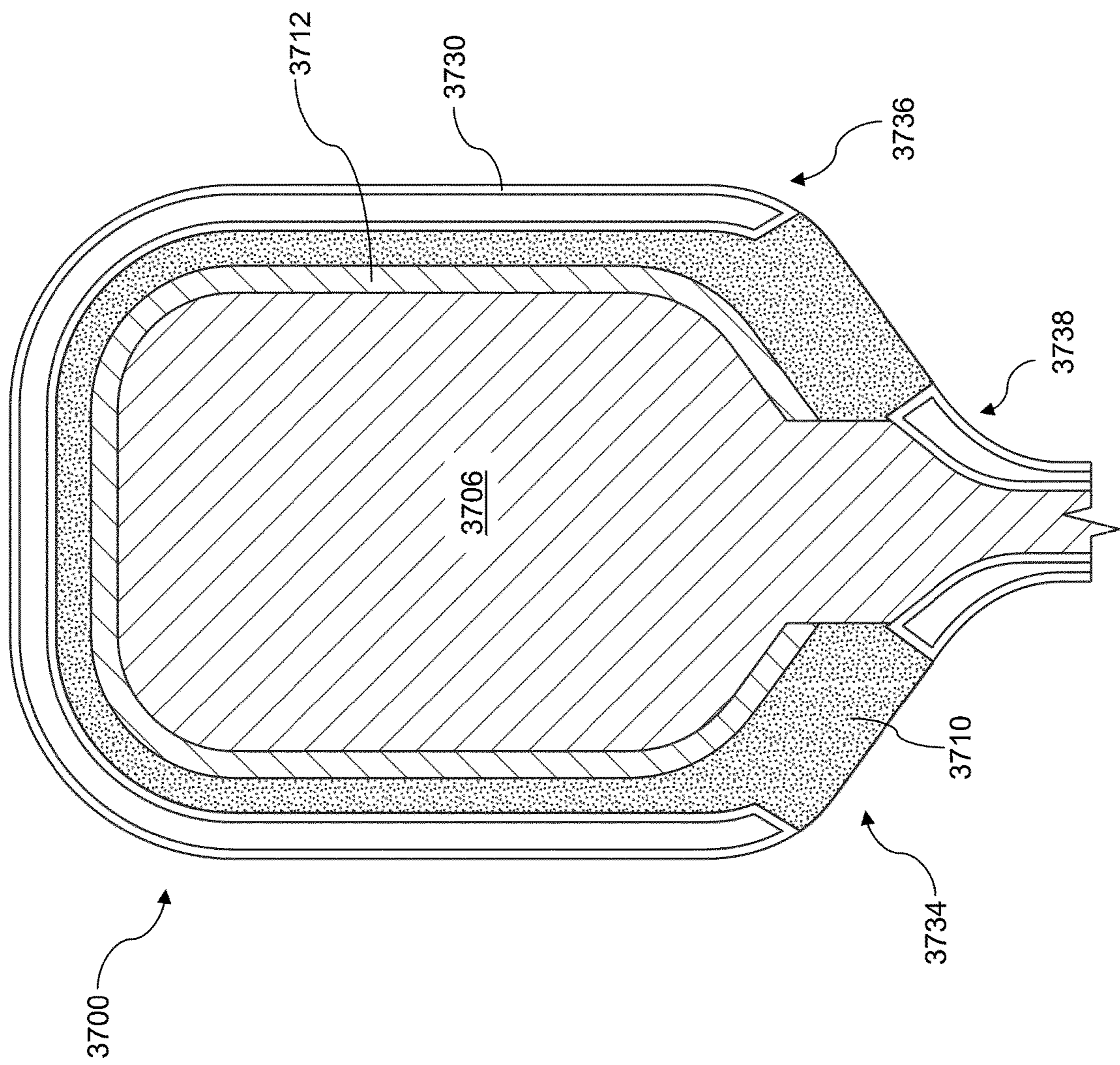

FIG. 37

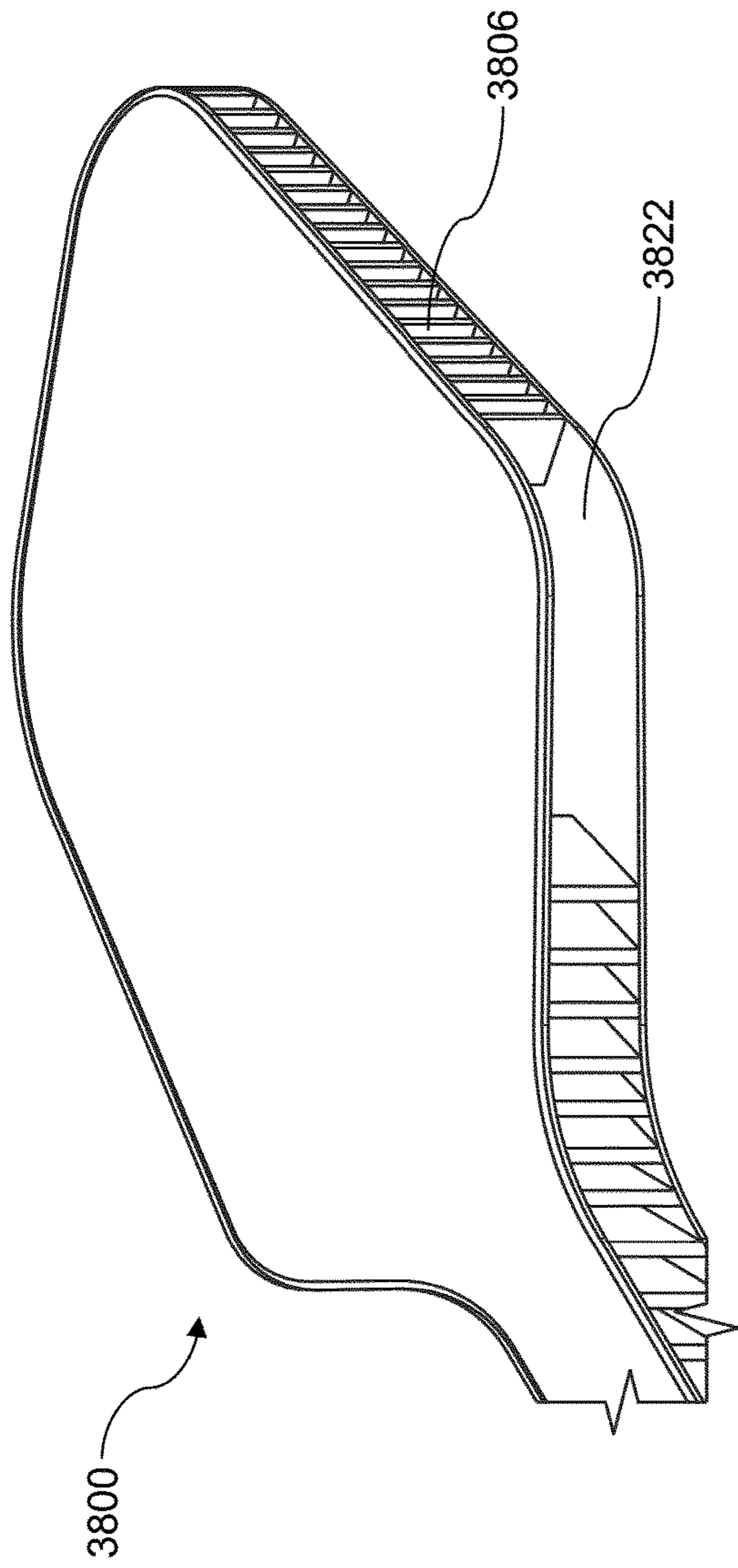

FIG. 38A

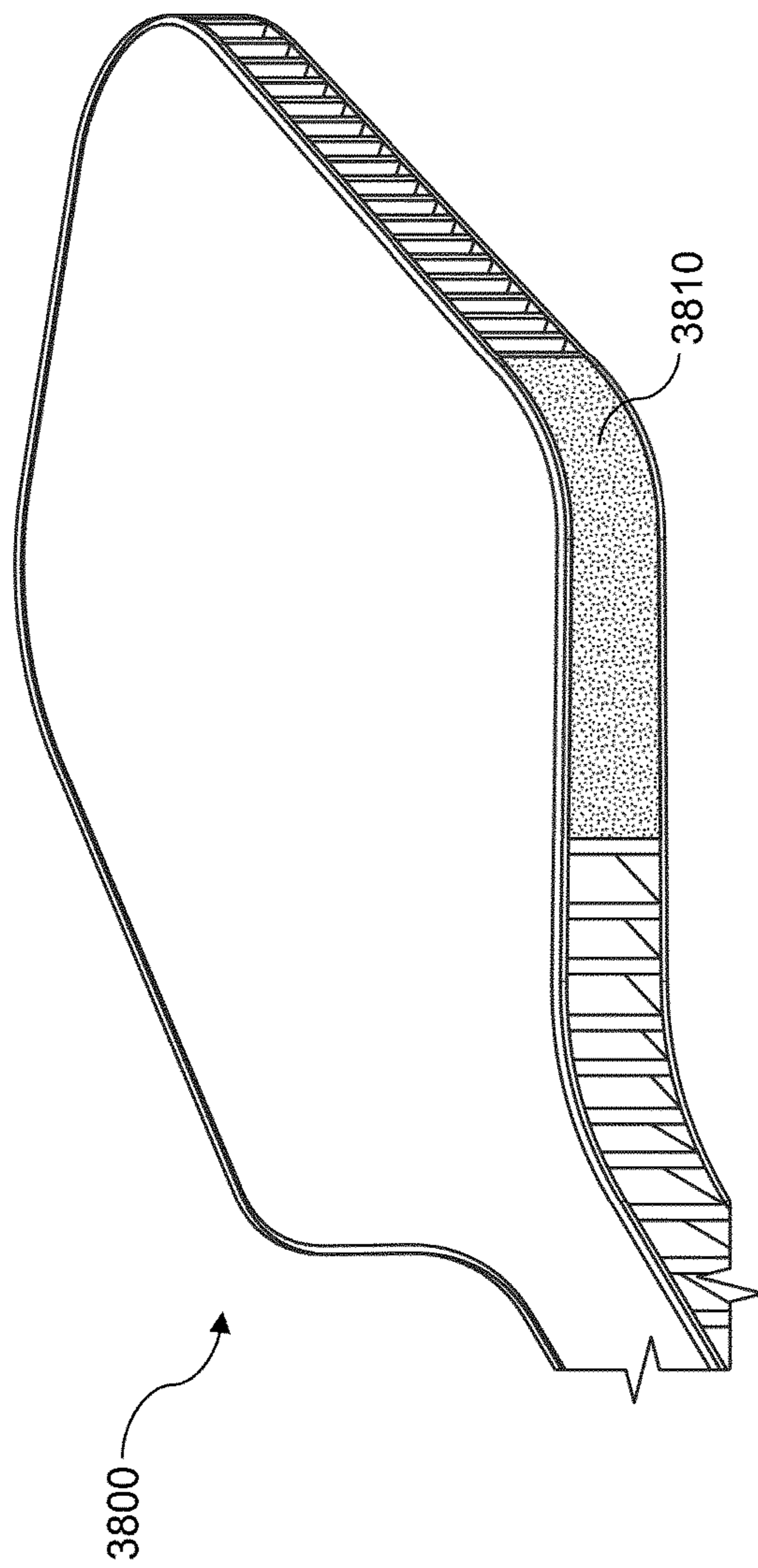

FIG. 38B

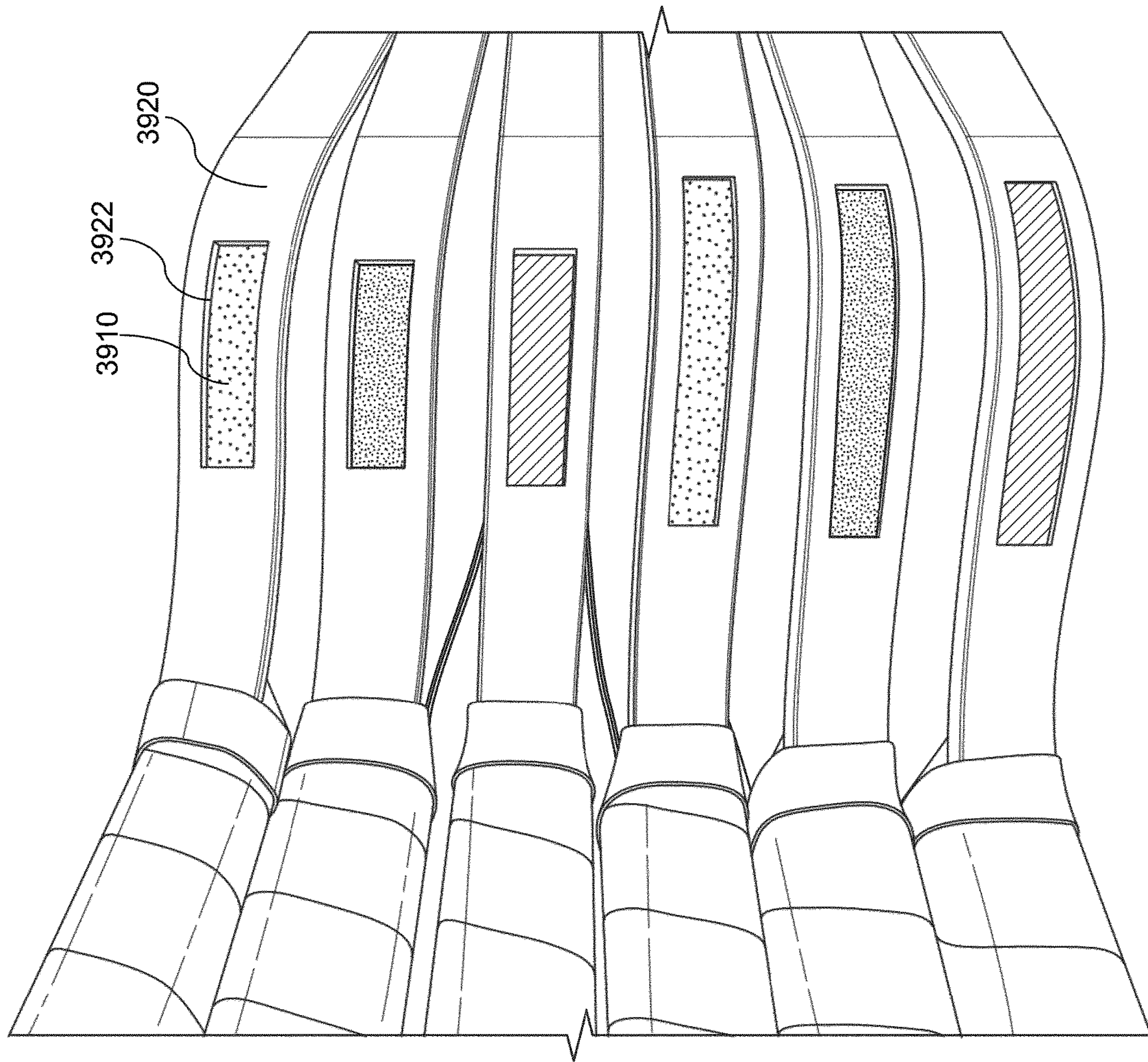

FIG. 39

US 12,357,891 B2

1
GAME PADDLE

CROSS-REFERENCE TO RELATED
APPLICATIONS

This application is a bypass continuation that claims priority to International Patent Application No. PCT/US2024/042535 filed on Aug. 15, 2024, which claims priority to U.S. Provisional Pat. App. Ser. No. 63/535,565 filed on Aug. 30, 2023, and U.S. Provisional Pat. App. Ser. No. 63/543,865 filed on Oct. 12, 2023. International Patent Application No. PCT/US2024/042535 also claims priority to U.S. patent application Ser. No. 18/389,174 filed on Nov. 13, 2023, which itself claims priority to U.S. Provisional Pat. App. Ser. No. 63/535,565 filed on Aug. 30, 2023, and U.S. Provisional Pat. App. Ser. No. 63/543,865 filed on Oct. 12, 2023. Each of the foregoing applications is hereby incorporated by reference in its entirety.

FIELD

The present disclosure generally relates to game paddles and the like—e.g., pickleball paddles—as well as methods for making and using the same.

BACKGROUND

Paddles for paddle sports have been used for ages. A paddle typically refers to a paddle that is not comprised of strings (such as a tennis racket). Paddles are used to play games such as pickleball, paddleball, and the like. In particular, pickleball is a paddle sport that generally combines elements of tennis, badminton, and ping-pong. It is played on a court with similar dimensions to a badminton court with a net dividing opposing sides. The game is played with a perforated plastic ball and solid paddles made of, for example, wood, graphite, and/or composite materials. In general, players use their paddles to hit the ball over the net, aiming to land the ball within the boundaries of the opposing side of the court.

Traditionally, paddles have been constructed with a solid core material, such as wood, foam, or composite materials, sandwiched between two outer surfaces. While these designs have proven effective, there is an ongoing desire to improve paddle performance, durability, and ergonomics. For example, an area of focus in paddle design has been weight distribution and balance. The distribution of weight within a paddle can affect its maneuverability, power transfer, and overall feel in a player's hand. Another consideration in paddle design is vibration dampening. The impact of a ball or other object on the paddle surface can create vibrations that may be transmitted to the player's hand and arm. Excessive vibration can lead to discomfort, reduced control, and potentially contribute to conditions such as tennis elbow. Durability is also a key factor in paddle design. Paddles are subjected to repeated impacts and varying environmental conditions, which can lead to wear and tear over time. Improving the longevity of paddles while maintaining their performance characteristics is an ongoing challenge.

As the popularity of paddle sports such as pickleball continues to grow, there remains a need for improvements that can enhance player performance, comfort, and enjoyment.

SUMMARY

The present teachings generally include game paddles such as pickleball paddles. For example, a pickleball paddle

2

disclosed herein may include a first surface, a second surface, and a core disposed therebetween, where the core defines a plurality of gaps that can accommodate one or more fillers, e.g., to provide vibration dampening and/or to otherwise affect performance, comfort, and enjoyment. In an example aspect, a gap is disposed on each side of the paddle near a throat portion thereof, where a first filler is inserted therein. The first filler may be viewable within such gaps—e.g., where an edge guard includes a window for viewing the first filler. A paddle according to the present teachings may have a frame (e.g., a frame that accommodates one or more gaps) or it may be frameless. In some aspects, a frame may also or instead include a filler disposed therein and/or adjacent thereto.

In one aspect, a pickleball paddle disclosed herein may include: a front surface; a back surface opposing the front surface; a core disposed between the front surface and the back surface; a gap formed in at least a portion of the core; a first filler disposed within at least a portion of the gap; a frame disposed about at least a head portion of the pickleball paddle along an edge portion thereof, the frame at least partially disposed between the front surface and the back surface along the edge portion, the frame defining a hollow interior portion; and a second filler disposed within at least a portion of the hollow interior portion of the frame.

Implementations may include one or more of the following features. One or more of the first filler and the second filler may include a foam material. One or more of the first filler and the second filler may include at least one of: a polymer, a thermoplastic, a thermoset material, a thermoplastic elastomer, an elastomer, a rubber, and an expandable material. One or more of the first filler and the second filler may include pressurized air. The second filler and the first filler may be the same material. The second filler and the first filler may be different materials. The gap may be disposed, at least in part, between the frame and the core. The gap may border the frame. The frame may surround the entire pickleball paddle. The frame may include carbon fiber. The frame may be a hollow cuboid structure. The hollow cuboid structure may be formed from a single piece of material. The core may at least partially include a honeycomb structure. The pickleball paddle may include an edge guard covering at least a portion of the frame along at least part of the head portion of the pickleball paddle.

In one aspect, a pickleball paddle disclosed herein may include: a front surface; a back surface opposing the front surface; a core disposed between the front surface and the back surface; a gap formed in at least a portion of the core along a throat portion of the pickleball paddle; and a first filler disposed within at least a portion of the gap.

Implementations may include one or more of the following features. The first filler may include a material structurally configured to absorb vibrations caused by striking a ball with one or more of the front surface and the back surface of the pickleball paddle. The pickleball paddle may include a frame disposed about at least a head portion of the pickleball paddle along an edge portion thereof, the frame at least partially disposed between the front surface and the back surface along the edge portion, the frame defining a hollow interior portion fillable with a second filler.

In one aspect, a method of manufacturing a pickleball paddle disclosed herein may include: forming a core of a pickleball paddle having a head portion and a handle portion; forming one or more gaps in the core of the pickleball paddle; inserting a first filler within at least a portion of the one or more gaps; wrapping a frame about a perimeter of the core; and affixing both a front surface and a back surface to

US 12,357,891 B2

3

the core wrapped by the frame. The frame may define a hollow interior portion. The method may further include inserting a second filler within at least a portion of the hollow interior portion of the frame.

In one aspect, a pickleball paddle disclosed herein may include: a first surface; a second surface; a core disposed between the first surface and the second surface, the core including a first material; at least two gaps in the core defined by absence of the first material of the core, a first gap of the at least two gaps disposed on a first side of the paddle substantially adjacent to a throat portion thereof, and a second gap of the at least two gaps disposed on a second side of the paddle substantially adjacent to the throat portion thereof; and a first filler disposed within one or more of the first gap and the second gap.

Implementations may include one or more of the following features. The pickleball paddle may include an edge guard disposed along a perimeter of a head portion of the paddle. The edge guard may define a void adjacent to each of the first gap and the second gap. The first filler may be viewable through the void. The void may include an at least semi-transparent material through which the first filler is viewable. The first filler may include one or more markings. The one or more markings may indicate a property of one or more of the paddle, the first filler, and the core. The one or more markings may include a color of the first filler. The one or more markings may include one or more of a texture and a pattern of the first filler. The void may be formed via a cutout in material of the edge guard. The first filler may be exposed to an external environment through the cutout. The pickleball paddle may include a frame disposed between the first surface and the second surface. The frame may be substantially disposed along, or adjacent to, a perimeter of a head portion of the paddle. The frame may accommodate the first gap and the second gap. The frame may include one or more indented portions that accommodate the first gap and the second gap. The frame may be absent along the first gap and the second gap. The frame may be shaped to form a boundary of each of the first gap and the second gap along an interior portion of the paddle. The pickleball paddle may include a gap formed in the core adjacent to the frame along an interior portion of the paddle. The pickleball paddle may include a second filler disposed within the gap. The second filler and the first filler may be the same. The second filler and the first filler may be different. One or more of the first filler and the second filler may include at least one of: a foam, ethyl vinyl acetate (EVA) foam, a polymer, a thermoplastic, a thermoset, a thermoplastic elastomer, an elastomer, a rubber, an expandable material, and a fluid. The frame may define an interior that may include a third filler. The third filler and the first filler may be the same. The third filler and the second filler may be different. The third filler may include compressed air. The first filler may be disposed within each of the first gap and the second gap. The first filler may be substantially the same within each of the first gap and the second gap. The first filler may infiltrate one or more of the first gap and the second gap by at least 5 millimeters. The first filler may include one or more of a foam, ethyl vinyl acetate (EVA) foam, a polymer, a thermoplastic, a thermoset, a thermoplastic elastomer, an elastomer, a rubber, an expandable material, and compressed air.

These and other features, aspects, and advantages of the present teachings will become better understood with reference to the following description, examples, and appended claims.

BRIEF DESCRIPTION OF THE DRAWINGS

The foregoing and other objects, features and advantages of the devices, systems, and methods described herein will

4

be apparent from the following description of particular embodiments thereof, as illustrated in the accompanying drawings. The drawings are not necessarily to scale, emphasis instead being placed upon illustrating the principles of the devices, systems, and methods described herein. In the drawings, like reference numerals generally identify corresponding elements.

FIG. 1A shows a front view of a paddle, according to a representative example.

FIG. 1B shows a top perspective view of a paddle, according to a representative example.

FIG. 1C shows a back perspective view of a paddle, according to a representative example.

FIG. 2 shows a diagonal view of a paddle after being cored out, according to a representative example.

FIG. 3 is a cross section of FIG. 2.

FIG. 4 shows a diagonal view of a paddle with foam added, according to a representative example.

FIG. 5 is a cross section of FIG. 4.

FIG. 6A shows a diagonal view of a paddle with a frame added, according to a representative example.

FIG. 6B is a cross section of FIG. 6A.

FIG. 7A shows a front perspective view of a paddle, according to a representative example.

FIG. 7B shows a back perspective view of a paddle, according to a representative example.

FIG. 7C shows a side view of a paddle, according to a representative example.

FIG. 7D shows a cross section of a paddle, according to a representative example.

FIG. 7E shows a front view of a paddle, according to a representative example.

FIG. 7F shows a cross section from Section 7F-7F shown in FIG. 7E.

FIG. 7G shows a cross section from Section 7G-7G shown in FIG. 7E.

FIG. 7H shows a detailed view of the area circled in FIG. 7F.

FIG. 7I shows a detailed view of the area circled in FIG. 7G.

FIG. 8 shows a front view of a paddle, according to a representative example.

FIG. 9 shows a front view of a paddle, according to a representative example.

FIG. 10 shows a front view of a paddle, according to a representative example.

FIG. 11 shows a front view of a paddle, according to a representative example.

FIG. 12 shows a front view of a paddle, according to a representative example.

FIG. 13 shows a front view of a paddle, according to a representative example.

FIG. 14 shows a front view of a paddle, according to a representative example.

FIG. 15 shows a perspective view of a paddle having a gap, according to a representative example.

FIG. 16 shows a perspective view of a paddle with a first filler filling a gap, according to a representative example.

FIG. 17 shows a perspective view of a paddle with a frame added to the edge of the paddle, according to a representative example.

FIG. 18 is a cross section of FIG. 17 showing the core, first filler, and frame, according to a representative example.

FIG. 19 shows a perspective view of a paddle with filler on the inside, according to a representative example.

FIG. 20 shows a perspective view of a paddle with filler on the inside, according to a representative example.

US 12,357,891 B2

5

FIG. 21 shows a perspective view of a paddle with filler on the inside, according to a representative example.

FIG. 22 shows a perspective view of a paddle with filler on the inside, according to a representative example.

FIG. 23 shows a perspective view of a paddle with a gap in the throat, according to a representative example.

FIG. 24 shows a perspective view of a paddle with filler in the throat, according to a representative example.

FIG. 25 shows a left side view of a paddle, according to a representative example.

FIG. 26 shows a right side view of a paddle, according to a representative example.

FIG. 27 shows a top view of a paddle, according to a representative example.

FIG. 28 shows a bottom view of a paddle, according to a representative example.

FIG. 29 shows a perspective view of a frame for a paddle, according to a representative example.

FIG. 30 shows a paddle, according to a representative example.

FIG. 31 is a flow chart of a method for making a paddle, according to a representative example.

FIG. 32 shows a paddle with a viewable filler, according to a representative example.

FIG. 33 shows a paddle with a viewable filler, according to a representative example.

FIG. 34 shows a side view and a cross-sectional view of a paddle, according to a representative example.

FIG. 35 shows a cross-sectional view of the head of a paddle, according to a representative example.

FIG. 36 shows a cross-sectional view of the head of a paddle, according to a representative example.

FIG. 37 shows a cross-sectional view of the head of a paddle, according to a representative example.

FIG. 38A shows a first view during formation of a paddle, according to a representative example.

FIG. 38B shows a second view during formation of a paddle, according to a representative example.

FIG. 39 shows a plurality of paddles, according to representative examples.

DETAILED DESCRIPTION

The embodiments will now be described more fully hereinafter with reference to the accompanying figures, in which preferred embodiments are shown. The foregoing may, however, be embodied in many different forms and should not be construed as limited to the illustrated embodiments set forth herein. Rather, these illustrated embodiments are provided so that this disclosure will convey the scope to those skilled in the art.

All documents mentioned herein are hereby incorporated by reference in their entirety. References to items in the singular should be understood to include items in the plural, and vice versa, unless explicitly stated otherwise or clear from the text. Grammatical conjunctions are intended to express any and all disjunctive and conjunctive combinations of conjoined clauses, sentences, words, and the like, unless otherwise stated or clear from the context. Thus, the term “or” should generally be understood to mean “and/or” and so forth.

Recitation of ranges of values herein are not intended to be limiting, referring instead individually to any and all values falling within the range, unless otherwise indicated herein, and each separate value within such a range is incorporated into the specification as if it were individually recited herein. The words “about,” “approximately” or the

6

like, when accompanying a numerical value, are to be construed as indicating a deviation as would be appreciated by one of ordinary skill in the art to operate satisfactorily for an intended purpose. Similarly, words of approximation such as “about,” “approximately,” or “substantially” when used in reference to physical characteristics, should be understood to contemplate a range of deviations that would be appreciated by one of ordinary skill in the art to operate satisfactorily for a corresponding use, function, purpose, or the like. Ranges of values and/or numeric values are provided herein as examples only, and do not constitute a limitation on the scope of the described embodiments. Where ranges of values are provided, they are also intended to include each value within the range as if set forth individually, unless expressly stated to the contrary. The use of any and all examples, or exemplary language (“e.g.,” “such as,” or the like) provided herein, is intended merely to better illuminate the embodiments and does not pose a limitation on the scope of the embodiments. No language in the specification should be construed as indicating any unclaimed element as essential to the practice of the embodiments.

In the following description, it is understood that terms such as “first,” “second,” “top,” “bottom,” “up,” “down,” and the like, are words of convenience and are not to be construed as limiting terms unless specifically stated to the contrary. By way of example, the following description identifies a “first filler,” a “second filler,” a “third filler,” and so forth—where it will be understood that the “first,” “second,” “third,” etc., designations are used for convenient identification and potential differentiation from one another (e.g., when disposed in the same paddle), and—unless expressly described to the contrary or otherwise clear from the context—these terms are not otherwise limiting and do not have other meaning such as order of addition or similar. Further, unless expressly described to the contrary or otherwise clear from the context, any of the fillers described herein may be substituted with another filler.

In general, the devices, systems, kits, and methods disclosed herein relate to paddles such as pickleball paddles with one or more gaps formed in a core portion thereof that can accommodate one or more fillers, e.g., to provide vibration dampening and/or to otherwise affect performance, comfort, and enjoyment. It will be understood that, while this disclosure may emphasize the present teachings in the context of pickleball, the present teachings may be adapted and practiced in other sports and activities, including without limitation one or more of: tennis, badminton, squash, racquetball, table tennis (ping pong), and the like. Thus, it shall be understood that, unless expressly stated to the contrary, or otherwise clear from the context, the present teachings are intended to include comparable equipment in other sports/activities in addition to, or instead of, pickleball.

A paddle can be used to play games like pickleball, racquetball, paddleball, etc. The paddle may be solid, meaning that it is not made of string with holes between the string (such as a tennis racket). The paddle can have some foam (or other filler) on the inside alongside other material(s) such as core; the filler can serve to increase power, soften feel and reduce vibration.

In an example embodiment, the paddle can be made with a manufacturing process as follows. The process can begin with using an original paddle. The paddle has a front and back surface and a core on the inside, in a “sandwich structure.” The front and back surfaces can be made from any material, such as one, two, three, four, or more layers of unidirectional or a weave of carbon, glass, and/or any

US 12,357,891 B2

7

natural or synthetic fiber and prepreg impregnated with any kind of resin. The core can be comprised of any open-cell structure and/or lattice (e.g., honeycomb) of, for example, polypropylene, aluminum, NOMEX, KEVLAR or another aramid, and/or any other synthetic or natural material.

The process then may core out (remove) a portion of the core. The portion of the core that is removed (gap) may depend on the embodiment—e.g., in different embodiments, different portions of the core can be cored out. The gap can be from 0.1 mm to 100 mm deep (from the edge to the center of the paddle). The process may then use a first filler (e.g., foam) to fill in the cored out portion (gap) of the core. In an example, instead of the first filler, the cored out portion (gap) can be left hollow.

The process may then insert a first filler (e.g., foam) into the gap. Note that the first filler can be a single material or a combination of at least two different materials. The process may then wrap a frame (such as a carbon frame) around the perimeter of the entire paddle. In an example, the frame can be an airtight hollow cuboid structure that has a second filler (e.g., foam) inside the frame. Note that, in an example, the frame may not be airtight. The second filler can be made from a single material or a combination of at least two different materials. In an alternate example, the frame can simply be a solid material wrapped around the perimeter. The second filler can be the same material(s) as the first filler or it can be a different material(s). In an example, the frame can be hollow. Note that a frame aspect ratio can be defined as the height of the frame divided by the width of the frame, and in an example, the frame aspect ratio would be lower than a predefined number (e.g., 4).

FIG. 1A is a drawing showing a front view of a paddle **100**, according to an example. The front view and back view may be identical. FIG. 1B is a drawing showing a top perspective view of the paddle, according to an example. FIG. 1C is a drawing showing a back perspective view of the paddle, according to an example. The paddle **100** may be utilized to create an improved paddle as described herein. Note that any paddles described herein are not limited to any particular shape, and any shape and/or thickness can be used. The front surface **101** and the back surface **102** can be made from any material, such as 1 to 4 or more layers of unidirectional or a weave of carbon, glass, and/or any natural or synthetic fiber and prepreg, impregnated with any kind of resin that is commonly used for the composite materials. Typically, the front surface **101** and the back surface **102** are made from the same material, although this is not required. A handle **105** is on the bottom of the paddle **100** and a head **110** is above the handle **105**. Example dimensions for such a paddle can be as follows: 15-17 inches (38.10-43.18 cm) in length by 7-9 inches (17.78-22.86 cm) in width, or 16.5 inches (41.91 cm)×7.5 inches (19.05 cm) or 16 inches (40.64 cm)×8 inches (20.32 cm). Grip length may be: 4-6 inches (10.16-15.24 cm), or 4.75-5.75 inches (12.065-14.605 cm). Grip circumference may be: 4-4.5 inches (10.16-11.43 cm), or 4-4.3 inches (10.160-10.922 cm). It will be understood that the aforementioned dimensions are just examples and any other dimensions can be used.

Note that the handle **105** can be defined as the bottom of the paddle up until the point where the curvature of the perimeter of the paddle (without a grip) starts to change (e.g., a straight line starts to curve). This point is shown in FIG. 1A by the dotted line 'H'. The face of the paddle can be considered the rest of the paddle, that is, from the handle to the top of the paddle. The face can be broken up into two sections, the head **110** and the throat **103**. The head **110** may

8

be from the top of the paddle down to where the perimeter starts to curve (from a straight edge) which is shown in FIG. 1A by the dotted line 'T'. The throat **103** may be the region between the head and the handle. Thus, the face of the paddle may include only the head **110** and the throat **103** but not the handle **105**. The height of the face is shown by the dotted line 'F' in FIG. 1A. All sections (e.g., head, throat, handle) are delineated by horizontal lines in FIG. 1A. These sections can be considered to extend throughout the thickness of the paddle.

An alternative method of determining the head and the throat sections is as follows. The height of the face may be determined by measuring the distance from the top of the paddle to where the handle begins (which can be determined based on when the curvature becomes straight, or by the use of a different material for the handle, etc.). The bottom one third of this height (e.g., the bottom one third of the face) may be the throat, and the top two thirds of this height (e.g., the top two thirds of the face) may be the head. As an example of this method, assume the height of the face (shown as vertical line F) in FIG. 1A is 10 inches (25.4 cm) from the top of the paddle to the top of the handle. The 10 inches does not include the handle. Then the throat cutoff line (shown as horizontal line T) is just at the lower one third of the face height, that is 3.33 inches (8.4582 cm) over the top of the handle is the throat (or 6.66 inches (16.9164 cm) below the top of the paddle). The region below the throat cutoff line and above the handle may be the throat region. While FIG. 1A is drawn as two-dimensional, the regions described herein may extend into the thickness of the paddle.

FIG. 2 is a diagonal view showing a paddle after it is cored out, according to an example. A core **200** may be present between the front surface **101** and the back surface **102**. The core **200** can be comprised of any open-cell structure (or a plastic sheet closing the cells), lattice (e.g., honeycomb), and/or any other such structure, comprised of polypropylene, aluminum, NOMEX, KEVLAR, or any other synthetic or natural material. "Coring out" may include removing sections of the core **200** from the paddle **100**. This can be done by using a drill or other tool which creates a gap **202** where the core **200** previously existed. See operation **3102** and its accompanying description for more information on an example coring out operation.

FIG. 3 is a cross section of FIG. 2, according to an example. Between the top surface **101** and the bottom surface **102** is the gap **202**. The gap **202** can be from 0.1 to 100 mm in depth (from the edge to the center of the paddle), it can be continuous around all the paddle, or split in two, three, four, or more sections of different lengths, depths, and shapes. The height of the gap can vary from 0.1 to 25 mm or to the max thickness of the core. The gap can be of any shape, concave, convex, U shape, or others.

FIG. 4 is a diagonal view of the paddle with foam added, according to an example. A first filler **400** may be added in the gap **202**, although it may not completely fill the gap **202** as room can be left for a frame (e.g., carbon frame). The first filler **400** can be Ethyl Vinyl Acetate (EVA) foam, polymer, thermoplastic, thermoset, thermoplastic elastomer, elastomer, rubber, foam, expandable material, or a mixture of any combination of these. The first filler **400** can be of any density, viscosity, and hardness. See operation **3103** and its accompanying description for more information on how the filler may be applied.

The first filler **400** (and the gap **202** which it fills) can be of any cross-section shape; the height can vary from 0.1 to 25 mm or to the max thickness of the core; and the width (distance from the frame wall to the core) can vary from 0.1

US 12,357,891 B2

9

to 50 mm. The first filler **400** can be continuous around all the core or can be split in two, three, or more sections with the same or different geometries, dimensions, and materials. The first filler **400** can surround the entire paddle, just the head, or just specific areas.

FIG. **5** is a cross section of FIG. **4**, according to an example. Shown inside the gap **202** is the first filler **400**.

FIG. **6A** is a diagonal view of a paddle with a frame added (such as a carbon frame), according to an example. A frame **600** may be added around the edge of the paddle **100**. The frame **600** can be comprised of carbon, glass, and/or any synthetic or natural fiber with resin, plastic, rubber, metal, and/or any material that provides a rigid structure. The frame **600** can be of any cross-section shape, height, width, and length. It can be an entire piece or can be split into two, three, or more sections with same or different geometries and dimensions. The frame **600** can surround the entire paddle, just the head, just the handle, or just specific areas. See operation **3104** and its accompanying description for more information on how a frame may be applied. An edge guard (not pictured) can be optionally used (or not) to cover the frame and a small area of the surfaces on both sides.

FIG. **6B** is a cross section of FIG. **6A**, according to an example. The frame **600** may be a hollow cuboid (or other) structure which houses a second filler **605**. The second filler **605** can be polymer, thermoplastic, thermoset, thermoplastic elastomer, elastomer, rubber, foam, expandable material, or a mixture of any combination of these. The second filler **605** can be of any density, viscosity, and hardness, and can be a single material or combination of different materials. The second filler **605** can be the same material as the first filler **400** or it can be a different material. In certain embodiments, the second filler **605** can also be pressurized air (high pressure) since the frame **600** can be airtight or it can be hollow. Also shown is the core **200**. When the frame is a shell structure as shown, the frame wall can range from 0.01-10 mm, 0.1-10 mm, 0.1-4 mm, or other ranges. Frame height may be 1-20 mm or to the max thickness of the paddle. Frame width can be 1-30 mm, or 5-15 mm. The frame can also be a solid structure (not shell structure); in this case, the examples of dimensions could be the same, but there's no wall thickness in this case.

FIG. **7A** shows a front view of a paddle with a frame installed, according to an example. FIG. **7B** shows a back view of the paddle with the frame installed, according to an example. The paddle shown in FIGS. **7A** and **7B** may be the final paddle after a manufacturing process is complete. The first filler **400** and the second filler **605** may not be visible to the user because they are internal to the paddle. Thus, the final paddle may appear like FIGS. **7A** and **7B** because the internal structure (e.g., core, first filler, second filler, etc.) may not be visible. In other example embodiments, one or more of these internal structures may be visible, however.

FIG. **7C** shows a side view of a paddle, according to an example. FIG. **7D** shows a cross section shown in FIG. **7C**, according to an example. Shown is the frame **600** with the second filler **605** inside the frame **600**. The first filler **400** may be present inside the core **200** which fills the gap **202** previously made in the core **200**.

FIG. **7E** shows a front view of a paddle, according to an example. The back view of the final paddle may be identical to the front view. Note that the frame may surround the entire paddle. In an example, the frame does not surround the entire paddle but only a portion of it; for example, the frame may only surround a part of the head of the paddle, or just part of the handle, etc. FIG. **7F** shows a cross section from the Section **7F-7F** shown in FIG. **7E**, according to an

10

example. FIG. **7G** shows a cross section from the Section **7G-7G** shown in FIG. **7E**, according to an example. Note that in FIG. **7G** there may be no first filler **400** (as shown in FIG. **7F**) because the portion of the paddle shown in FIG. **7G** may not have been cored out and hence no first filler **400** was applied to that region. FIG. **7H** shows a detailed view of the area circled in FIG. **7F**, according to an example. Note that FIG. **7H** shows a height and width of the frame. The frame aspect ratio is the height/width. In one example, the frame aspect ratio may be smaller than 4 (or smaller than equal to 4). In another example, the frame aspect ratio may be smaller than 6, or smaller than 4, or smaller than 2, or other numbers. FIG. **7I** shows a detailed view of the area circled in FIG. **7G**, according to an example.

FIGS. **8-13** are each drawings showing a front view of a paddle, according to various examples. Note that the back view of each paddle may be identical to the respective front view. All other structures not shown may be the same or similar as described herein. In each of these figures, the first filler is shown which may be inside the respective paddle and may not be visible to the user. Before the first filler is added, as described herein. The section where the first filler is shown may have been cored out (the gap). All of these examples may also have a frame (e.g., with the second filler inside the frame) applied around the entire edge. Thus, the embodiments shown in FIGS. **8-13** can be constructed using a process described herein, and can have the same general structure as shown in FIGS. **2-7I** but for the different location and shape of the gap which was cored out of the original paddle and filled with the first filler. Note that other configurations of core and first filler can be used as well, and these are just examples. Note that in FIGS. **8-13**, the first filler and the second filler may both not be visible to the user as they may both be embedded inside the paddle (e.g., the first filler being inside the game and the second filler being inside the frame). The paddles shown in FIGS. **8-13** may appear as shown in FIGS. **7A** and **7B** because any internal structures (e.g., first filler **400**, second filler **605**, core **200**, etc.) may not be visible as it would be covered by the front and back surfaces and possibly the frame **600**.

In the example shown in FIGS. **7D** and **8-13**, the gap and filler used to fill the gap may be located near the perimeter of the head (the head being opposite of the handle) of the paddle. In a further example, the gap and filler used to fill the gap can be in other locations in the paddle (not just near the perimeter), although typically closer to the handle than the head. FIGS. **14-18** illustrate examples of a paddle where the gap and filler used to fill the gap are present in various locations inside the paddle. Note that the construction process can be the same as shown with respect to FIGS. **1-13**.

FIG. **14** is a front view showing a paddle before it is cored out, according to an example. FIGS. **15-19** show a process of how a dampener may be applied to a paddle. Note that the core may be present throughout the paddle (as shown in other figures) and may be surrounded by a front and back surface. The outer surfaces can be comprised of one, two, three, four, or more layers of unidirectional or weave of carbon, glass, and/or any natural or synthetic fiber and prepreg, impregnated with any kind of resin. The core **200** can be comprised of a honeycomb structure of polypropylene, aluminum, Nomex, Kevlar, and/or any other synthetic or natural material. The core is not limited to a honeycomb structure. The core can form the entire paddle (head and handle) or the head only. The core can be surrounded by an edge guard, or any type of frame, or it may be edgeless.

FIG. **15** is a perspective view showing the paddle from FIG. **14** after it was cored out, according to an example. Note

US 12,357,891 B2

11

that a gap **1500** in the core **1400** may be where the core **1400** was drilled (or other process) to form the gap **1500**. Note that the gap **1500** may be near the handle **1501**. FIG. **16** is a perspective view showing a first filler filling in the gap (as described herein), according to an example. The gap **1500** (and hence the first filler) may extend throughout the entire paddle. Note that the gap **1500** may extend throughout the paddle and out through the opposite side of the paddle. While the gap **1500** extends throughout the paddle, the paddle does not collapse into two sections because the front and back surface keep the paddle together until the first filler is inserted to fill the gap **1500**. Because the gap is typically smaller than the total thickness of the paddle, leaving some part of the original core, which also helps the paddle to not collapse. FIG. **19** shows the first filler **1600** extending throughout the paddle.

The gap **1500** may be used to place a vibration dampener (e.g., the first filler) but can also be hollow partially or completely filled. The gap can be of any dimension, cross section, shape, and any position, it can be continuous across the paddle, or split into two, three, four, or more sections of different lengths, widths, and shapes. It can be linear or curved, in the center of the paddle and/or along the edges. The gap can be inside the sandwich structure and/or reach/pass the front and back surfaces. It can be on the head (edges, center, top, bottom), neck, and/or handle of the paddle. Multiple gaps can be used simultaneously in the same or different parts of the paddle. If the gap is located in the edges of the paddle, it can be exposed to the outside (on both edges of the paddle), or it can be covered with a frame, edge guard, or any other material or structure.

The gap **1500** may be filled with a first filler **1600**. The first filler can be a foam, polymeric foam, solid, liquid, gel of any type of polymer, thermoplastic, thermoset, thermoplastic elastomer, elastomer, rubber, expandable material, and any other material or a mixture of them. The first filler can fill completely or partially the gap **1500**. The first filler can be directly touching the core structure, or it can be covered/encapsulated by other material, for example a thermoplastic film or carbon fiber, not limited to these materials. If the gap **1500** reaches the surface, the first filler **1600** can be exposed on the surface or can be covered with glass fiber, carbon fiber, adhesive or any other material.

FIG. **17** is a perspective view showing a frame added to the edge of the paddle from FIG. **16**, according to an example. After the gap **1500** is filled with the first filler **1600**, a frame **1700** can be added to the edge (perimeter) as described herein. Note that in some examples, where there is no gap on the edge of the paddle, adding the frame may not be done. The frame **1700** can have a second filler as described herein. Note that the final paddle may appear as shown in FIGS. **7A** and **7B**.

FIG. **18** is a cross section of FIG. **17** showing the core, foam, and carbon frame, according to an example. The frame **1700** may contain a second filler **1800**. FIG. **19** is a perspective view showing a front of a paddle showing the first filler on the inside, according to an example. The first filler **1600** may be inside the gap **1500** cut inside the core **1400**. The first filler **1600** may not be visible to the user as it can be entirely inside the paddle; in other examples, the first filler **1600** may be visible to a user.

FIGS. **19-22** are each drawings showing a diagonal front view of a paddle, according to various examples. Note that the back view of each paddle may be identical to the respective front view. All other structures not shown may be the same or similar as described herein. The paddles shown in FIGS. **19-22** can be constructed as described herein.

12

FIG. **19** is an example of a paddle showing a horizontal gap (and first filler) across the entire paddle, and this may represent what was shown being constructed in FIGS. **15-18**. FIG. **20** is an example of a paddle showing a horizontal gap (and first filler) in the sides of the paddle. FIG. **21** is an example of a paddle showing a horizontal gap (and first filler) in the center of the paddle. The gap (and first filler) is not limited to these examples or to horizontal gaps, and other shapes, dimensions, and configurations can be used also or instead. Note in FIGS. **19-21**, the first filler may or may not be completely inside the paddle, and thus may or may not be visible to the user. The second filler may also or instead be completely inside the paddle (inside the frame) and may not be visible to the user, or it may be visible in some aspects.

Note that when the gap and first filler are entirely in-between the head and the handle (the throat), it can be referred to as a dampener (such as shown in FIGS. **19-21**). In other words, a dampener may not have any portion of filler outside of the throat of the paddle (e.g., above the throat line or below the top of the handle). Note that when the gap and the first filler is near the perimeter/edges of the paddle (such as shown in FIGS. **7D** and **8-13**), then it can affect properties of the paddle, which can for example increase spin and boost of a ball striking the paddle. This can be because the first filler (e.g., foam) inside the paddle, in an example, can slightly vibrate when the paddle strikes a ball, which enhances the feel for the player when striking the ball. A dampener can reduce vibration on the handle. Note that in an example, a dampener can be considered a piece of foam that is entirely inside the throat of the paddle. Note that in an example, using the frame can be optional. In one example, if a paddle contains a dampener, then there would not be a frame used.

Note that the ratio of volume of first filler to volume of the core can be relatively large (meaning there is a relatively large amount of first filler used in the paddle). For example, in a particular paddle, a ratio r is equal to the volume of all first filler divided by the volume of all core. In an example, the ratio r can be 5%. In another embodiment, r can be from 5% to 75%. In another example, r can be from 25% to 50%. In another embodiment, r can be from 10% to 20%. In an example, an acceptable range of r would be from 1% to 30%.

Note that both a dampener (e.g., gap with filler between the head and the handle) and gap with filler near the edge can be combined into the same paddle, see FIGS. **8, 9, 22**. FIG. **22** is a perspective view showing a front of another alternative paddle showing first filler both around the perimeter as well as throughout a section between the head and the handle, according to an example.

FIG. **23** is a perspective view of a paddle with a gap cut through the front and back surfaces, according to an example. Note in this embodiment, a gap **2300** may be cut throughout the core, front, and back surface of the paddle.

FIG. **24** is a perspective view of a paddle with the gap cut through the front and back surfaces with filler, according to an example. A first filler **2400** may be inserted into the gap **2300**. The front surface and back surface can then be coated with an external coating (but alternatively could be visible without any coating/cover), such as a carbon fiber layer, to cover the entire front and back surface including the first filler **2400**. As such, the first filler **2400** may or may not be visible to a user after the external coating is applied. FIGS. **17, 19-22**, and **24** may all appear visually as FIGS. **7A** and **7B**, e.g., with all of the internal structures (e.g., core **200**, first filler **400**, second filler **605**, etc.) covered by the front and back surfaces and possible a frame **600**.

US 12,357,891 B2

13

FIG. 25 is a left side view of a paddle, according to an example. FIG. 26 is a right side view of the paddle, according to an example. FIG. 27 is a top view of a paddle, according to an example. FIG. 28 is a bottom view of a paddle, according to an example. Note that a completed (finished) paddle can appear on the outside as shown in FIGS. 7A and 7B as well as FIGS. 25-28. Note that the surfaces shown in FIGS. 25-28 may be all frame 600 although the shading does not match the shading used in the other figures with regard to the frame 600 in order to show contours.

FIG. 29 is a drawing showing a perspective view of the frame, according to an example. Shown is the frame which can be made out of carbon or other material. The frame (before curing/heating) is malleable so it can be bent around the perimeter of the paddle. It can be glued onto the edge of the paddle using glue or other adhesive. While shown with an open face in FIG. 29, the face can be closed (sealed) on both ends, thereby creating an airtight frame in which pressurized air or other materials can be sealed therein.

FIG. 30 is a drawing of a paddle, according to an example. The paddle can have an optional grip 3000, an optional end cap 3001, and an optional edge guard 3002. The edge guard can be used or not to cover the frame and a small area of the surfaces on both sides. The edge guard can be made from polyvinyl chloride (PVC), any type of polymer, thermoplastic, thermoset, elastomer, rubber, foam, expandable material, or a mixture of any of these. Example dimensions for such a paddle can be any as described herein, although these are just examples and any other dimensions can be used. When determining the locations/dimensions of the head, throat, handle, face, etc., the edge guard, end cap, and grip may not be used.

FIG. 31 is a flow chart illustrating a method 3100 used to construct a paddle, according to an example. This method 3100 (and its individual operations) can be used to construct a paddle described or illustrated herein.

In operation 3101, a paddle can be constructed or provided. The paddle may be constructed from a core which can be comprised of any open-cell structure or lattice of polypropylene, aluminum, Nomex, Kevlar, or any other synthetic or natural material. Outer surfaces (e.g., front surface and back surface) can be comprised of any material, for example one, two, three, four, or more layers of unidirectional or weave of carbon, glass, or any natural or synthetic fiber and prepreg, impregnated with any kind of resin are commonly used for the outer surface. The front and back surface can be glued to the core, creating a "sandwich" of core between the front and back surfaces. See FIGS. 1A, 1B, 1C for an original paddle. Note that in an example, the front and back surface can be glued onto the core after the core is cored out, providing easier access to the core.

From operation 3101, the method can proceed to operation 3102, in which portions of the core are cored out (removed) to create a gap. This can be done by using a tool such as a router, running drill, press, saw, or any other mechanical tool. The coring can be performed through edges of the paddle (see FIG. 2). In the embodiment where the intended gap does not touch the edge of the core, the coring out of the core could be performed before assembling the sandwich structure (e.g., before attaching the front surface and back surface to the core). This method of coring out the core can also be done even if the gap does touch the edge of the core. The gap can be from 0.1 to 100 mm depth (from the edge to the center of the paddle), it can be continuous around all the paddle, or split in two, three, four, or more sections of different lengths, depths, and shapes. The height

14

of the gap can vary from 0.1 to 25 mm or to the max thickness of the core. The gap can be of any shape, concave, convex, U shape, or others. There can also be shapes created within the core while the core is attached to the edge.

From operation 3102, the method proceeds to operation 3103, in which a filler (first filler) may be placed (inserted) into the gap. The filler can be pressurized (e.g., in a can) and sprayed in, or can be spread inside the gap using a tool (e.g., applicator gun such as a foam dispensing gun), or the like. The gap can be entirely filled in with the first filler or some gaps can still remain. In an example, the first filler can be cut to the exact shape of the gap and added by hand. The first filler can be an empty space (or pressured air and the frame can be airtight), or filled with any type of polymer, thermoplastic, thermoset, thermoplastic elastomer, elastomer, rubber, foam, polymeric foam, expandable material, or a mixture of them. The first filler material can be expandable, for example if the first filler material is foam it can be expandable foam. The first filler can be of any cross-section shape, the height can vary from 1 to 25 mm or to the max thickness of the core, the width (distance from the frame wall to the core) can vary from 0.1 to 50 mm. According to the gap geometries and shape, the first filler can be continuous around all the core or can be split in two, three, or more sections with same or different geometries, dimensions, and materials. The first filler can surround the entire paddle, just the head, or just specific areas.

From operation 3103, the method can proceed to operation 3104, which adds the frame to the edge of the paddle. The frame may be a hollow cuboid structure (or other structure which does not have to be hollow) which wraps around the entire edge of the paddle. The frame can be bendable in order to mold it to the shape of the edge of the paddle. An adhesive (e.g., glue, cement, etc.) can be used to adhere the frame to the paddle. The frame (e.g., carbon frame) may be bendable before a heating operation, but after a heating the resin may set and the frame may become hard. The frame can be adhered to the paddle by the resin in the carbon fiber, and because it gets hard, it may not change the shape of the frame. The frame can be made of carbon, glass, fiberglass, thermoplastic, or any synthetic or natural fiber with resin, plastic, rubber, metal, or any material that provides a rigid structure. To make the carbon frame, a sheet of carbon fiber prepreg (impregnated with thermoset resin) may be rolled to form a tube structure. Inside this tube there may be a piece (e.g., continuous and long, about the same length of the tube) of the second filler (such as expandable foam). The frame can be of any cross-section shape, height, width, and length. It can be an entire piece or can be split in two, three, or more sections with same or different geometries and dimensions. The frame can surround the entire paddle, just the head, just the handle, or just specific areas.

The frame can be hollow or filled with a filler (e.g., a second filler). This second filler can be of any polymer, thermoplastic, thermoset, thermoplastic elastomer, elastomer, rubber, foam, polymeric foam, expandable material, or a mixture of them. The second filler can be of any density, viscosity, and hardness. The second filler can be inserted into the frame using a number of alternate methods (in addition to those described herein), such as blowing it inside, injecting it, pressuring the second filler and then shooting it inside the frame, etc. The second filler (e.g., expandable foam) can be inserted into carbon frame by hand, it is a solid piece before the hot molding process. The second filler can be air and the frame can be airtight.

From operation 3104, the method proceeds to operation 3105, which heats up the paddle. Once the first filler has

US 12,357,891 B2

15

been added to the paddle (inside gap(s) in the core) and the frame has been added to surround the paddle, and the second filler is added inside the frame, and the front and back surface are attached (e.g., glued) to the core, then the paddle can be placed inside a mold. The frame can be bent around the edge (perimeter) of the paddle. The paddle can then be heated in the mold which has a shape to match the paddle. The mold is closed with high pressure inside and the temperature is raised inside the mold to around 100 degrees Celsius or more for 2-20 minutes or more. With the high temperature, the second filler inside the frame may expand so the frame gets its shape. The first filler inside the gap(s) also can expand therein. If expandable foam (e.g., a polymer with a foamy agent) is being used for the first filler and/or the second filler, then the expandable foam can expand and harden when heated. Also, with the high temperature, the resin impregnated in the frame may set (become hard) so it will be a solid piece after the mold is opened.

Note that all features, embodiments, method, step, etc., may be applied to any other embodiment described herein. In addition, all features, embodiments, methods, steps, etc., may be combined with any other without limitation. In addition, all paddles herein may be (unless stated otherwise) symmetrical, that is, the back side/surface may be identical to the front side/surface. For any side or portion of any paddle that is not shown or described in the drawings/specification, that side or portion may be identical (symmetrical) to its corresponding side or portion that has been shown (or identical/symmetrical to other paddles shown herein). For example, if the left side of a paddle is shown, if the right side of the paddle is not shown or described, it can be assumed that the appearance and structure of the right side is identical to the left. If the bottom of a paddle is not shown, it can be assumed that the bottom of that paddle is identical to a bottom shown of another paddle shown herein. As such, parts and structures described herein can be combined and mixed without limitation. The same would hold true for front and back surfaces, etc. Any part mentioned or illustrated can be made from any suitable material, including any material mentioned herein.

In certain aspects of the present teachings, a pickleball paddle may include: a front surface; a back surface opposing the front surface; a core disposed between the front surface and the back surface; a gap formed in at least a portion of the core; a first filler disposed within at least a portion of the gap; a frame disposed about at least a head portion of the pickleball paddle along an edge portion thereof, the frame at least partially disposed between the front surface and the back surface along the edge portion, the frame defining a hollow interior portion; and a second filler disposed within at least a portion of the hollow interior portion of the frame.

Implementations may include one or more of the following. One or more of the first filler and the second filler may include a foam material. One or more of the first filler and the second filler may include at least one of: a polymer, a thermoplastic, a thermoset material, a thermoplastic elastomer, an elastomer, a rubber, and an expandable material. One or more of the first filler and the second filler may include pressurized air. The second filler and the first filler may be the same material. The second filler and the first filler may be different materials. The gap may be disposed, at least in part, between the frame and the core. The gap may border the frame. The frame may surround the entire pickleball paddle. The frame may include carbon fiber. The frame may be a hollow cuboid structure. The hollow cuboid structure may be formed from a single piece of material. The core may at least partially include a honeycomb structure. The paddle

16

may further include an edge guard covering at least a portion of the frame along at least part of the head portion of the pickleball paddle.

In certain aspects of the present teachings, a pickleball paddle may include: a front surface; a back surface opposing the front surface; a core disposed between the front surface and the back surface; a gap formed in at least a portion of the core along a throat portion of the pickleball paddle; and a first filler disposed within at least a portion of the gap. The first filler may include a material structurally configured to absorb vibrations caused by striking a ball with one or more of the front surface and the back surface of the pickleball paddle. The pickleball paddle may further include a frame disposed about at least a head portion of the pickleball paddle along an edge portion thereof, the frame at least partially disposed between the front surface and the back surface along the edge portion, the frame defining a hollow interior portion fillable with a second filler.

In certain aspects of the present teachings, a method of manufacturing a pickleball paddle may include: forming a core of a pickleball paddle having a head portion and a handle portion; forming one or more gaps in the core of the pickleball paddle; inserting a first filler within at least a portion of the one or more gaps; wrapping a frame about a perimeter of the core; and affixing both a front surface and a back surface to the core wrapped by the frame. The frame may define a hollow interior portion. The method may further include inserting a second filler within at least a portion of the hollow interior portion of the frame.

The present teachings may include pickleball paddles and similar with a gap disposed on each side of the paddle near a throat portion thereof, where a filler is inserted therein. This filler may be viewable within such gaps—e.g., where an edge guard includes a void and/or window for viewing the filler and/or associated features, markings, colorings, or similar. These markings may, for example, provide information about various properties of the paddle, a filler material, and/or the core. A paddle according to the present teachings may have a frame (e.g., a frame that accommodates one or more gaps) or it may be frameless. In some aspects, a frame may also or instead include a filler disposed therein and/or adjacent thereto as described herein.

The design of a paddle as described herein may allow for the customization of various paddle characteristics, potentially leading to improved performance and user experience. For instance, the use of filler material within gaps of the core (or otherwise having gaps, with or without filler) may allow for adjustments in weight distribution, vibration dampening, and/or other performance characteristics. Further, the potential inclusion of a frame and an edge guard may contribute to the structural integrity and durability of a paddle.

It will be understood that one or more of the fillers described herein, e.g., with reference to any of the figures described herein, may include any of the features, characteristics, materials, material properties, and so on, of any one or more other fillers described herein. For instance, any of the one or more fillers (e.g., a first filler, a second filler, a third filler, and a fourth filler) may include any one or more of the following, or any combination thereof: a foam material, a polymer, a thermoplastic, a thermoset material, a thermoplastic elastomer, an elastomer, a rubber, an expandable material, a gas (e.g., pressurized air), a fluid, and the like. Further, one or more of the fillers may be the same as another filler found in the same paddle (e.g., a first filler and a second filler may be the same). Alternatively, one or more

US 12,357,891 B2

17

of the fillers may be different from another filler found in the same paddle (e.g., a first filler and a second filler may be different).

FIGS. 32 and 33 show a paddle with a viewable filler, according to representative examples. Each paddle 3200, 3300 may include a playing surface 3201, 3301 (one of the first surface and second surface described herein), a core disposed between playing surfaces, a gap in the core adjacent to a throat portion 3204, 3304 of the paddle 3200, 3300, and a first filler 3210, 3310 disposed within the gap. Each paddle 3200, 3300 may further include an edge guard 3220, 3320.

The playing surface 3201, 3301 of the paddles 3200, 3300 (or any other paddle described herein) may be textured or otherwise structurally configured to enhance control and/or striking during play. For instance, a textured surface may increase friction between the paddle 3200, 3300 and a ball, potentially allowing for more precise shots or improved spin and/or control.

The gap, which is shown filled with the first filler 3210, 3310 in FIGS. 32 and 33, may be formed at or near the throat of the paddle 3200, 3300, e.g., where the head transitions to the handle. Other gaps are also or instead possible, such as any as described herein or shown in the accompanying figures. In some aspects, the gap(s) and/or filler(s) disposed therein may be viewable by a user in a finished paddle. Viewable gaps and/or fillers may serve a functional and/or aesthetic purpose. In some aspects, the filler material may be colored or otherwise marked, e.g., to provide a contrast with the other components of the paddle 3200, 3300. The color and/or marking of the filler material may be selected based on aesthetic considerations. Also, or instead, the color and/or marking of the filler material may be used to indicate certain properties of the paddle 3200, 3300, such as an intended user, a weight and/or weight distribution, a flexibility or other similar property, a material property (of one or more components or features of the paddle, including internal and/or external components or features), a performance characteristic, a make, model and/or branding, and the like.

In this manner, filler and/or other internal structures, materials, and the like contained within the paddle 3200, 3300 may include one or more markings therein or thereon. For example the first filler 3210, 3310 may include one or more markings. In some implementations, a marking indicates a property of one or more of the paddle 3200, 3300, a filler, a core, and the like. In some implementations, a marking includes a color of an internal component, such as a color of the first filler 3210, 3310. Also or instead, one or more markings may include a texture, an alphanumeric character, a symbol, a branding and/or logo, a scannable code (e.g., a QR code) or similar, an identification marking (e.g., a model number), a color code, an artistic marking, an engraving or inscription, a pattern, a label and/or tag, combinations thereof, and the like.

The edge guard 3220, 3320 may be similar to any as described herein or otherwise known in the art. Further, the edge guard 3220, 3320 may include a void 3222, 3322 (and/or window) to provide for viewing of, and/or to provide a visual indication of, an internal structure of the paddle 3200, 3300. This visibility may be achieved by forming a void 3222, 3322 and/or window in the edge guard 3220, 3320, e.g., to align with a gap in the core. That is, in some aspects, a paddle 3200, 3300 described herein includes an edge guard 3220, 3320 disposed along a perimeter of a head portion of the paddle 3200, 3300. The edge guard 3220, 3320 may define a void 3222, 3322 adjacent to one or more gaps in the paddle 3200, 3300—e.g., each of a first gap and

18

a second gap disposed at or near a throat portion 3204, 3304 of the paddle 3200, 3300. By way of example, and as shown in FIG. 32, the void 3222 may be formed via a cutout in material of the edge guard 3220. And, in some aspects, such as that shown in FIG. 32, the first filler 3210 may be exposed to an external environment through the cutout in the edge guard 3220. Alternatively, and as shown in FIG. 33, the void 3322 may include an at least semi-transparent material (e.g., fully transparent, tinted, colored, and the like) through which the first filler 3310 is viewable. That is, a window may be formed over the void 3322 using transparent material or the like such that the first filler 3310 is viewable through the window and/or void 3322. This window may be formed by one or both of a covering over the void 3322 (e.g., over the top of the void 3322) and/or by insertion of an at least semi-transparent material within the void 3322.

FIG. 34 shows a side view 3400a and a cross-sectional view 3400b of a paddle 3400, according to a representative example. The paddle 3400 may include a first surface 3401 and a second surface 3402 opposing the first surface 3401. A core 3406 may be disposed between the first surface 3401 and the second surface 3402. The core 3406 may be made of a first material, e.g., polypropylene, aluminum, NOMEX, KEVLAR or another aramid, and/or any other synthetic and/or natural material. In general, the core 3406 may be any as described herein, e.g., a solid core and/or one including a honeycomb structure and/or an open-cell structure and/or lattice structure. It will be understood that the paddle 3400 shown in FIG. 34 may include any one or more of the features described above, e.g., with reference to FIGS. 1-33.

The paddle 3400 may include at least two gaps in the core 3406, e.g., a first gap 3408a and a second gap 3408b. These gaps may be defined by an absence of the material of the core 3406. In some aspects, the first gap 3408a may be disposed on a first side of the paddle 3400 substantially adjacent to a throat portion 3404 thereof, while the second gap 3408b may be disposed on a second side of the paddle 3400 substantially adjacent to the throat portion 3404. The first gap 3408a and the second gap 3408b may have a similar size and/or shape, or they may be different.

A first filler 3410 may be disposed within one or more of the first gap 3408a and the second gap 3408b (e.g., the first filler 3410 may be disposed within each of the first gap 3408a and the second gap 3408b). In certain aspects, the first filler 3410 is substantially the same within each of the first gap 3408a and the second gap 3408b. The first filler 3410 may infiltrate one or more of the first gap 3408a and the second gap 3408b by at least 5 millimeters. For example, the first gap 3408a and the second gap 3408b may extend inwardly by at least 5 mm from the perimeter of the paddle 3400. The first filler 3410 may fill the entire extent of one or more of the first gap 3408a and the second gap 3408b, or the first filler 3410 may infiltrate one or more of the first gap 3408a and the second gap 3408b by at least 5 mm leaving the remainder of the respective gap empty. In yet some other aspects, the filler is different within each of the first gap 3408a and the second gap 3408b—e.g., having a different material property and/or aesthetic appearance.

In some implementations, one or more other fillers may be present in other gaps in the core 3406, which may be the same as or different from the first filler 3410, e.g., a second filler 3412 and/or a third filler 3432 may also or instead be present. The fillers may be any as described herein, for example including without limitation one or more of a foam (e.g., Ethyl Vinyl Acetate (EVA) foam), a polymer, a thermoplastic, a thermoset, a thermoplastic elastomer, an elastomer, a rubber, an expandable material, a fluid (e.g., com-

US 12,357,891 B2

19

pressed air and/or another gas such as an inert gas), and the like. In certain aspects, the second filler **3412** and the first filler **3410** are the same; in other aspects, the second filler **3412** and the first filler **3410** are different. Similarly, in certain aspects, the third filler **3432** and the first filler **3410** are the same; in other aspects, the third filler **3432** and the first filler **3410** are different.

The paddle **3400** may further include a frame **3430** disposed between the first surface **3401** and the second surface **3402**. In some aspects, the frame **3430** may be substantially disposed along, or adjacent to, a perimeter of a head portion of the paddle **3400**. In some aspects, the frame **3430** is solid; in other aspects, the frame **3430** is hollow and/or includes one or more hollow portions. The frame **3430** may define an interior comprising a third filler **3432**, which may be any as described herein, including a foam, compressed air or another inert gas, and similar. In some cases, the third filler **3432** may surround the core **3406** of the paddle **3400**, and a portion of the frame **3430** and/or the second filler **3412** may be located between the third filler **3432** and the core **3406**.

As stated herein and as shown in the figures, the frame **3430** may accommodate one or more gaps in the paddle **3400**, e.g., the first gap **3408a** and the second gap **3408b**. For example, in certain implementations, the frame **3430** may include one or more indented portions **3434** that accommodate the first gap **3408a** and the second gap **3408b**, and/or other gaps disposed within the paddle **3400**. For example, the frame **3430** may include one or more indented portions **3434** in the throat region of the paddle **3400**, where the frame may extend continuously around the perimeter of the head region of the paddle and may be offset inwardly from the perimeter of the paddle in the indented portions. Alternatively, the frame **3430** may be absent along the first gap **3408a** and the second gap **3408b** (see, e.g., FIG. **37**), or it may be shaped to form a boundary of each of the first gap **3408a** and the second gap **3408b** along an interior portion of the paddle **3400**.

The paddle **3400** may include a gap formed in the core **3406** adjacent to the frame **3430** along an interior portion of the paddle **3400**. This gap may extend, e.g., along a majority of a first side of the head portion, along a top of the head portion, and along a majority of a second side of the head portion. The second filler **3412** (or another filler) may be present within all of, or a portion of, this gap as shown in FIG. **34**. In some aspects, a filler may be used to bond or otherwise adhere different internal portions of the paddle **3400**. For example, the second filler **3412** may be used to form a bond between the core **3406** and the frame **3430**.

An edge guard may be disposed along a perimeter of the head portion of the paddle **3400**. The edge guard may define a void **3422** adjacent to each of the first gap **3408a** and the second gap **3408b**, through which the first filler **3410** may be viewable.

It will be understood that a plurality of gaps of different shapes and sizes may be present within the paddles described herein, where one or more fillers (the same or different fillers) may be present within all or a portion of these gaps. FIG. **34** shows one example cross-section of a paddle according to the present teachings, and FIGS. **35-37** below show further example cross-sections of paddles according to the present teachings, where it will be understood that different examples are also or instead possible without departing from the scope of this disclosure.

FIG. **35** shows a cross-sectional view of the head of a paddle, according to a representative example. The paddle **3500** may include a core **3506** disposed between a first

20

surface and a second surface. In some aspects, the core **3506** may define multiple gaps, including a first gap **3508a**, a second gap **3508b**, a third gap **3508c**, and a fourth gap **3508d**. One or more of these gaps may contain (wholly or partially) one or more fillers, such as any as described herein, where different gaps may include the same fillers as one another, or different fillers.

By way of example, the first gap **3508a** and the second gap **3508b** may contain a first filler **3510**; the third gap **3508c** may contain a second filler **3512** (or it may not contain any filler in certain aspects); and the fourth gap **3508d** may contain a fourth filler **3514**. In an aspect, one or more of the gaps (e.g., the third gap **3508c** and the fourth gap **3508d**) may occupy a shared region where material has been removed from the core **3506**. In other words, a gap may not be, or may only partially be, adjacent to the core **3506**. A gap may instead be wholly or partially adjacent to another gap. More or less gaps with more or less fillers may also or instead be included in the paddle **3500**.

The paddle **3500** may further include a frame **3530** disposed along a perimeter of the paddle. In some aspects, the frame **3530** may define an interior comprising a third filler **3532**. The frame **3530** may be shaped or configured to accommodate one or more of the various gaps and fillers within the paddle **3500**.

The arrangement and configuration of the core **3506**, gaps, fillers, and frame **3530**—in this paddle **3500** and/or other paddles described herein—may allow for the customization and/or optimization of the paddle's performance characteristics, such as weight distribution, vibration dampening, and overall feel during play.

FIG. **36** shows a cross-sectional view of the head of a paddle, according to a representative example. The paddle **3600** shown in this figure may be similar to, and may include one or more features of, the paddle **3500** described above, but where the paddle **3600** of FIG. **36** does not include a third or fourth gap as shown above. That is, the paddle **3600** may include a core **3606** disposed between a first surface and a second surface, a first filler **3610** disposed within at least a portion of one or more gaps in the core **3606**, and a frame **3630** disposed along a perimeter of the paddle. In some aspects, the frame **3630** may define an interior comprising a third filler **3632**.

FIG. **37** shows a cross-sectional view of the head of a paddle, according to a representative example. The paddle **3700** shown in this figure may be similar to, and may include one or more features of, the paddles described above, but where the paddle **3700** of FIG. **37** includes a frame **3730** with multiple portions—e.g., a first portion **3736** and a second portion **3738**.

In this manner, in certain aspects, the frame **3730** may include areas of absence **3734**, where the frame **3730** is not present along certain sections of the paddle's perimeter. This configuration may allow for direct exposure of the core **3706** and/or fillers (e.g., the first filler **3710**) to the perimeter of the paddle **3700** and/or an external environment.

Thus, the core **3706** may define one or more gaps, and a first filler **3710** may be disposed within at least a portion of one or more gaps in the core **3706**. The first filler **3710** may extend along certain sections of the paddle's internal structure and/or perimeter, potentially providing targeted vibration dampening, weight distribution characteristics, and the like. In some implementations, a second filler **3712** may also be present within the paddle **3700**, which may be the same as or different from the first filler **3710**. The second filler **3712** may be positioned in different locations within the core **3706**, potentially allowing for further customization of the

US 12,357,891 B2

21

paddle's performance characteristics. Other gaps and fillers may also or instead be present.

FIG. 38A shows a first view during formation of a paddle 3800 and FIG. 38B shows a second view during formation of a paddle 3800, according to a representative example. By way of example, the paddle 3800 may be a frameless paddle. The paddle 3800 may include a core 3806 disposed between a first surface and a second surface, where FIG. 38A shows cutout 3822 in the core 3806 to form a gap as described herein, where the gap may be filled with a first filler 3810 as shown in FIG. 38B. In some aspects, the cutout 3822 is formed in the core 3806 of the paddle 3800, and then the first and second surfaces are applied before the gap formed by the cutout 3822 is filled with a filler. Other manufacturing techniques are also or instead possible.

FIG. 39 shows a plurality of paddles, according to representative examples. As shown in the figure, the paddles may include an edge guard 3920 disposed along a perimeter of a head portion thereof. The edge guard 3920 may define a void 3922 adjacent to gaps that are filled with a filler, e.g., a first filler 3910. The void 3922 may allow for direct exposure of the first filler 3910 to the external environment, thereby providing visual indication of the paddle's internal structure or performance characteristics. The void 3922 may also or instead include an at least semi-transparent material (e.g., a clear filler) and/or window and/or covering, allowing for a visual indication of the paddle's internal structure or performance characteristics.

The paddles shown in FIG. 39 demonstrate how the fillers (and/or gaps and/or voids) may be different in different paddles—e.g., in visual appearance, size, shape, material properties, and the like. As described herein, the different visual appearance can indicate different models, brands, properties, and so forth, of different paddles.

The foregoing description, for purpose of explanation, has been described with reference to specific embodiments. However, the illustrative discussions above are not intended to be exhaustive or to limit the disclosure to the precise forms disclosed. Many modifications and variations are possible in view of the above teachings.

Unless the context clearly requires otherwise, throughout the description, the words “comprise,” “comprising,” “include,” “including,” and the like are to be construed in an inclusive sense as opposed to an exclusive or exhaustive sense; that is to say, in a sense of “including, but not limited to.” Additionally, the words “herein,” “hereunder,” “above,” “below,” and words of similar import refer to this application as a whole and not to any particular portions of this application.

It will be appreciated that the devices, systems, and methods described above are set forth by way of example and not of limitation. For example, regarding the methods provided above, absent an explicit indication to the contrary, the disclosed steps may be modified, supplemented, omitted, and/or re-ordered without departing from the scope of this disclosure. Numerous variations, additions, omissions, and other modifications will be apparent to one of ordinary skill in the art. In addition, the order or presentation of method steps in the description and drawings above is not intended to require this order of performing the recited steps unless a particular order is expressly required or otherwise clear from the context.

The method steps of the implementations described herein are intended to include any suitable method of causing such method steps to be performed, consistent with the patentability of the following claims, unless a different meaning is expressly provided or otherwise clear from the context. So,

22

for example performing the step of X includes any suitable method for causing another party such as a remote user, a remote processing resource (e.g., a server or cloud computer) or a machine to perform the step of X. Similarly, performing steps X, Y, and Z may include any method of directing or controlling any combination of such other individuals or resources to perform steps X, Y, and Z to obtain the benefit of such steps. Thus, method steps of the implementations described herein are intended to include any suitable method of causing one or more other parties or entities to perform the steps, consistent with the patentability of the following claims, unless a different meaning is expressly provided or otherwise clear from the context. Such parties or entities need not be under the direction or control of any other party or entity, and need not be located within a particular jurisdiction.

While particular embodiments have been shown and described, it will be apparent to those skilled in the art that various changes and modifications in form and details may be made therein without departing from the spirit and scope of this disclosure and are intended to form a part of the invention as defined by the following claims, which are to be interpreted in the broadest sense allowable by law.

What is claimed is:

1. A pickleball paddle, comprising:

a first surface;

a second surface;

a core disposed between the first surface and the second surface, the core comprising a first material;

at least two gaps in the core defined by absence of the first material of the core, a first gap of the at least two gaps disposed on a first side of the paddle substantially adjacent to a throat portion thereof, and a second gap of the at least two gaps disposed on a second side of the paddle substantially adjacent to the throat portion thereof;

a first filler disposed within one or more of the first gap and the second gap; and

a frame disposed between the first surface and the second surface, wherein the frame is accommodated by the first gap and the second gap, and wherein the frame is shaped to form a boundary of each of the first gap and the second gap along an interior portion of the paddle.

2. The pickleball paddle of claim 1, further comprising an edge guard disposed along a perimeter of a head portion of the paddle.

3. The pickleball paddle of claim 2, wherein the edge guard defines a void adjacent to each of the first gap and the second gap.

4. The pickleball paddle of claim 3, wherein the first filler is viewable through the void.

5. The pickleball paddle of claim 4, wherein the void includes an at least semi-transparent material through which the first filler is viewable.

6. The pickleball paddle of claim 4, wherein the first filler includes one or more markings.

7. The pickleball paddle of claim 6, wherein the one or more markings indicate a property of one or more of the paddle, the first filler, and the core.

8. The pickleball paddle of claim 6, wherein the one or more markings include a color of the first filler.

9. The pickleball paddle of claim 6, wherein the one or more markings include one or more of a texture and a pattern of the first filler.

10. The pickleball paddle of claim 3, wherein the void is formed via a cutout in material of the edge guard.

US 12,357,891 B2

23

11. The pickleball paddle of claim 10, wherein the first filler is exposed to an external environment through the cutout.

12. The pickleball paddle of claim 1, wherein the frame is substantially disposed along, or adjacent to, a perimeter of a head portion of the paddle.

13. The pickleball paddle of claim 1, wherein the frame includes one or more indented portions that are accommodated by the first gap and the second gap.

14. The pickleball paddle of claim 12, further comprising a gap formed in the core adjacent to the frame along an interior portion of the paddle.

15. The pickleball paddle of claim 14, further comprising a second filler disposed within the gap.

16. The pickleball paddle of claim 15, wherein the second filler and the first filler are the same.

17. The pickleball paddle of claim 15, wherein the second filler and the first filler are different.

18. The pickleball paddle of claim 15, wherein one or more of the first filler and the second filler include at least one of: a foam, Ethyl Vinyl Acetate (EVA) foam, a polymer, a thermoplastic, a thermoset, a thermoplastic elastomer, an elastomer, a rubber, an expandable material, and a fluid.

19. The pickleball paddle of claim 15, wherein the frame defines an interior comprising a third filler.

20. The pickleball paddle of claim 19, wherein the third filler and the first filler are the same.

21. The pickleball paddle of claim 19, wherein the third filler and the second filler are different.

22. The pickleball paddle of claim 19, wherein the third filler includes compressed air.

23. The pickleball paddle of claim 1, wherein the first filler is disposed within each of the first gap and the second gap.

24

24. The pickleball paddle of claim 1, wherein the first filler infiltrates one or more of the first gap and the second gap by at least 5 millimeters.

25. The pickleball paddle of claim 1, wherein the first filler includes one or more of a foam, Ethyl Vinyl Acetate (EVA) foam, a polymer, a thermoplastic, a thermoset, a thermoplastic elastomer, an elastomer, a rubber, an expandable material, and compressed air.

26. A pickleball paddle, comprising:

a first surface;

a second surface;

a core disposed between the first surface and the second surface, the core comprising a first material;

at least two gaps in the core defined by absence of the first material of the core, a first gap of the at least two gaps disposed on a first side of the paddle substantially adjacent to a throat portion thereof, and a second gap of the at least two gaps disposed on a second side of the paddle substantially adjacent to the throat portion thereof;

a first filler disposed within one or more of the first gap and the second gap; and

a frame disposed between the first surface and the second surface, wherein the frame is accommodated by the first gap and the second gap via the frame including one or more indented portions that are accommodated by the first gap and the second gap.

27. The pickleball paddle of claim 26, further comprising an edge guard disposed along a perimeter of a head portion of the paddle.

28. The pickleball paddle of claim 27, wherein the edge guard defines a void adjacent to each of the first gap and the second gap.

29. The pickleball paddle of claim 28, wherein the first filler is viewable through the void.

* * * * *

EXHIBIT 4

**Exhibit 4 to Complaint
Infringement Claim Chart
U.S. Patent No. 12,357,891**

**Vegas Pickleball LLC d/b/a RPM Pickleball
Friction Pro Paddle**

The claim chart set forth below is provided based on information to date and may not be exhaustive. Plaintiff's investigation is ongoing. Plaintiff reserves the right to supplement and/or amend this exemplary infringement contention claim chart to identify additional asserted claims, accused products/instrumentalities, and/or to further identify where each element of each asserted claim is found in each accused product. For example, Plaintiff reserves the right to supplement and/or amend this exemplary infringement contention chart in view of any future discovery obtained from Defendant and/or third parties during the pendency of this litigation.

As used in claim chart below, the "RPM Accused Product(s)" include without limitation the following: the pickleball game paddles produced by Defendant Vegas Pickleball LLC d/b/a RPM Pickleball (hereinafter "RPM") including, but not necessarily limited to, Friction Pro paddles, as well as any other RPM product that shares a similar structure/configuration and/or operates in a manner consistent with the theory of infringement outlined in the claim chart below. Plaintiff contends that the RPM Accused Product(s)—which is also herein referred to as the Friction Pro—practices each of the claims of U.S. Patent No. 12,357,891 ("the '891 Patent") identified in the claim chart below in the manner shown and/or explained.

The RPM Accused Product(s)—along with the associated photographs and documents—discussed, cited, and/or otherwise referenced herein are representative in all material aspects of all other Accused Product(s) identified herein.

| | U.S. Patent No. 12,357,891 | RPM Friction Pro |
|-----------------------|---|--|
| | Claim 1 | |
| <p>1 [pre]</p> | <p>A pickleball paddle, comprising:</p> | <p>The RPM Friction Pro Paddle is a pickleball paddle. https://rpmpb.com/products/rpm-friction-pro-16mm-elongated-v2.</p>  |
| | | |

| | U.S. Patent No. 12,357,891 | RPM Friction Pro |
|-------------------|----------------------------|--|
| <p>1.a</p> | <p>a first surface;</p> | <p>The RPM Friction Pro Paddle includes a first surface (below):</p>  |
| <p>1.b</p> | <p>a second surface;</p> | <p>The RPM Friction Pro Paddle includes a second surface (below):</p> |

| | U.S. Patent No. 12,357,891 | RPM Friction Pro |
|------------|----------------------------|--|
| | |  |
| 1.c | | The RPM Friction Pro Paddle includes a core comprised of a first material disposed between the first surface and the second surface: |

| | U.S. Patent No. 12,357,891 | RPM Friction Pro |
|-------------------|--|--|
| | <p>a core disposed between the first surface and the second surface, the core comprising a first material;</p> |  <p>The photograph shows three cross-sections of a paddle. Each section features a central core with a honeycomb lattice structure. Red material is applied to the inner surfaces of the core. Labels with red lines point to the core, and yellow lines point to the surfaces. The labels are: 'Core (shown comprised of honeycomb lattice material)' and 'First/second surfaces'.</p> |
| <p>1.d</p> | <p>at least two gaps in the core defined by absence of the first material of the core,</p> | <p>The RPM Friction Pro Paddle includes at least two gaps in the core defined by absence of the first material of the core, a first gap of the</p> |

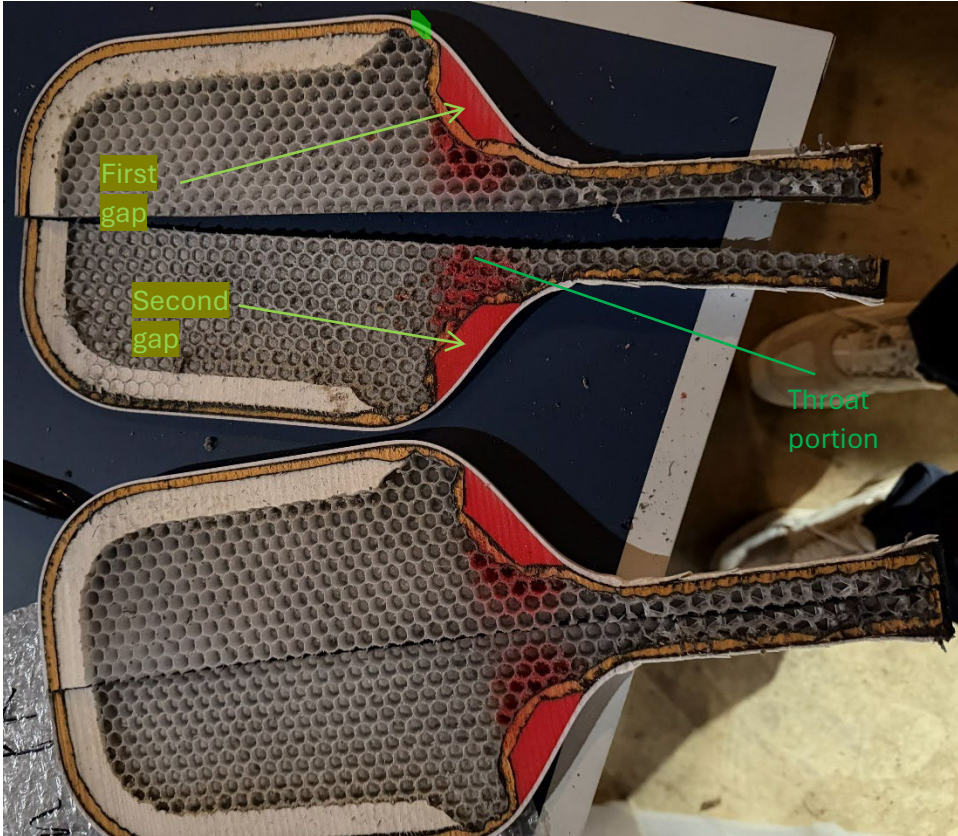
| U.S. Patent No. 12,357,891 | RPM Friction Pro |
|--|---|
| <p>a first gap of the at least two gaps disposed on a first side of the paddle substantially adjacent to a throat portion thereof, and a second gap of the at least two gaps disposed on a second side of the paddle substantially adjacent to the throat portion thereof;</p> | <p>at least two gaps disposed on a first side of the paddle substantially adjacent to a throat portion thereof, and a second gap of the at least two gaps disposed on a second side of the paddle substantially adjacent to the throat portion thereof:</p>  <p>The image shows three cross-sectional views of a paddle. The top view shows a 'First gap' on the left side and a 'Throat portion' at the right end. The middle view shows a 'Second gap' on the left side and a 'Throat portion' at the right end. The bottom view shows a 'Throat portion' at the right end. The paddle has a honeycomb-like internal structure and a red-colored throat portion.</p> |

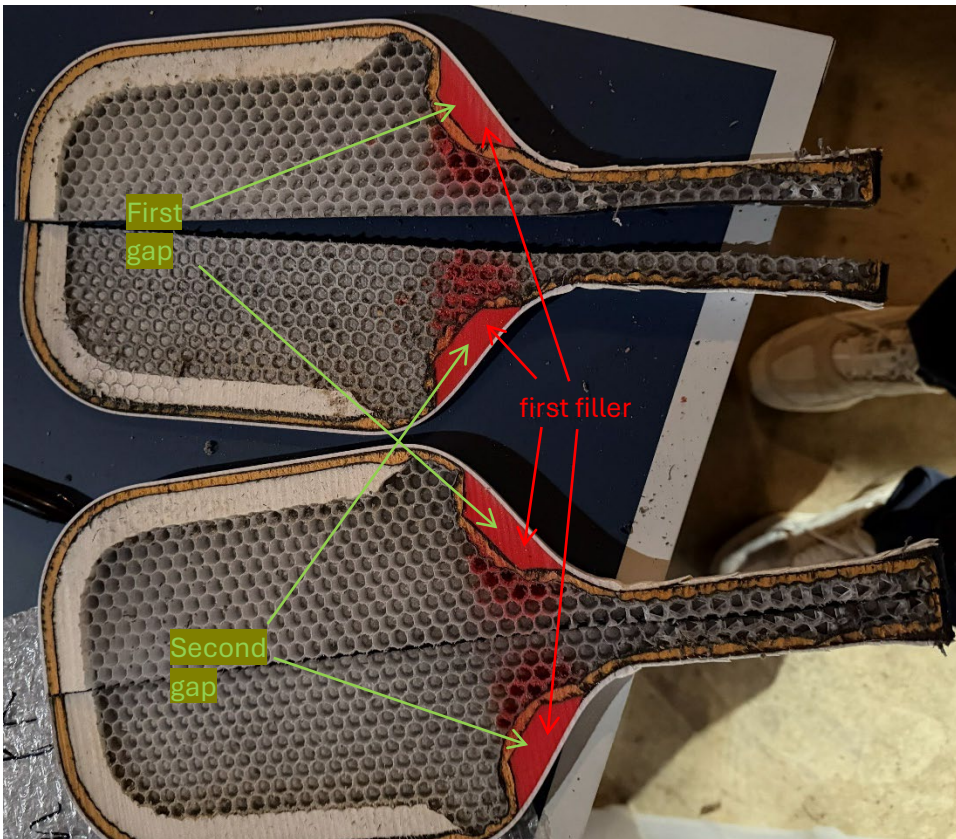
| | U.S. Patent No. 12,357,891 | RPM Friction Pro |
|-------------------|--|--|
| <p>1.e</p> | <p>a first filler disposed within one or more of the first gap and the second gap; and</p> | <p>The RPM Friction Pro Paddle includes a first filler disposed within one or more of the first gap and the second gap:</p>  <p>The image contains two photographs of a paddle's internal structure. The top photograph shows a cross-section of the paddle head with a honeycomb core. A green arrow points to a 'First gap' between the core and the inner shell. A red arrow points to a 'first filler' (red material) located in the gap between the core and the outer shell. The bottom photograph shows a similar cross-section, with a green arrow pointing to a 'Second gap' and a red arrow pointing to the 'first filler'.</p> |

| | U.S. Patent No. 12,357,891 | RPM Friction Pro |
|------------|--|---|
| 1.f | <p>a frame disposed between the first surface and the second surface, wherein the frame is accommodated by the first gap and the second gap, and wherein the frame is shaped to form a boundary of each of the first gap and the second gap along an interior portion of the paddle.</p> | <p>The RPM Friction Pro Paddle includes a frame disposed between the first surface and the second surface, wherein the frame is accommodated by the first gap and the second gap, and wherein the frame is shaped to form a boundary of each of the first gap and the second gap along an interior portion of the paddle:</p>  |

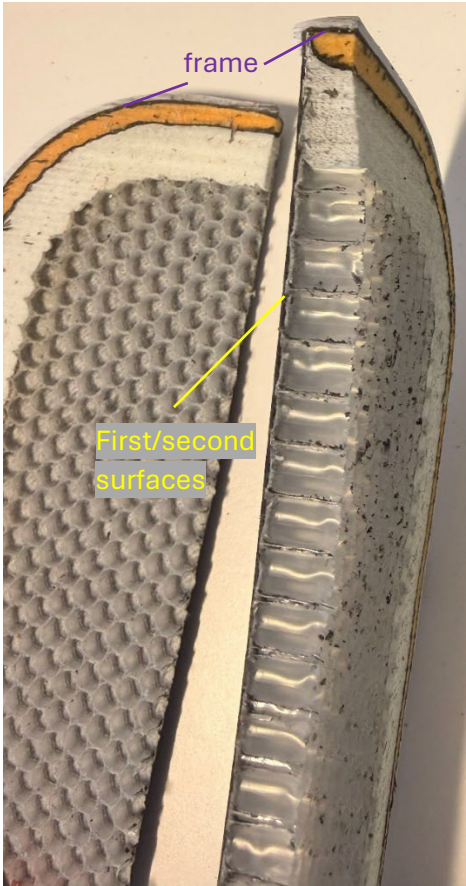
| | U.S. Patent No. 12,357,891 | RPM Friction Pro |
|------------------------|---|---|
| | |  |
| <p>26 [pre]</p> | <p>A pickleball paddle, comprising:</p> | <p>The RPM Friction Pro Paddle is a pickleball paddle:</p> |

| | U.S. Patent No. 12,357,891 | RPM Friction Pro |
|--------------------|----------------------------|---|
| | |  |
| <p>26.a</p> | <p>a first surface;</p> | <p>The RPM Friction Pro Paddle includes a first surface (below):</p> |

| | U.S. Patent No. 12,357,891 | RPM Friction Pro |
|--------------------|----------------------------|---|
| | |  |
| <p>26.b</p> | <p>a second surface;</p> | <p>The RPM Friction Pro Paddle includes a second surface (below):</p> |

| | U.S. Patent No. 12,357,891 | RPM Friction Pro |
|-------------|----------------------------|--|
| | |  |
| 26.c | | The RPM Friction Pro Paddle includes a core comprised of a first material disposed between the first surface and the second surface: |

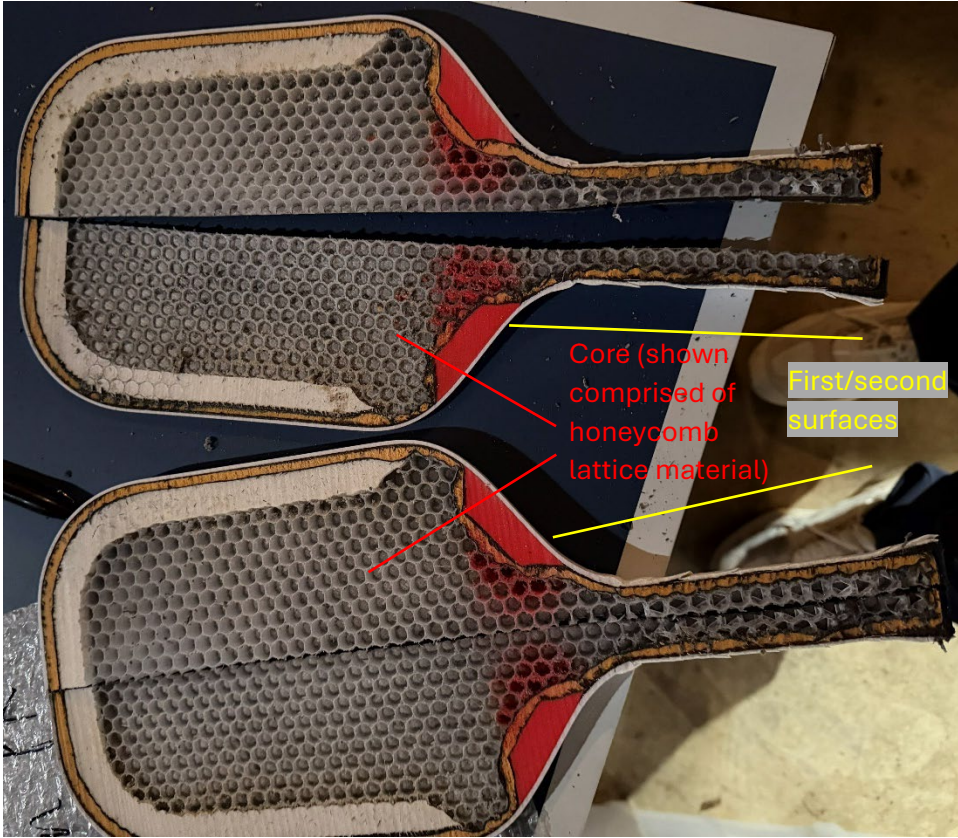
| | U.S. Patent No. 12,357,891 | RPM Friction Pro |
|--------------------|--|--|
| | <p>a core disposed between the first surface and the second surface, the core comprising a first material;</p> |  <p>The photograph shows three cross-sections of a paddle. The top section is a standard paddle with a uniform honeycomb core. The middle and bottom sections show the RPM Friction Pro paddle, which has a honeycomb core with two distinct gaps where the core material is absent. Red lines point to these gaps, with a label that reads "Core (shown comprised of honeycomb lattice material)". Yellow lines point to the top and bottom surfaces of the paddle, with a label that reads "First/second surfaces".</p> |
| <p>26.d</p> | <p>at least two gaps in the core defined by absence of the first material of the core,</p> | <p>The RPM Friction Pro Paddle includes at least two gaps in the core defined by absence of the first material of the core, a first gap of the</p> |

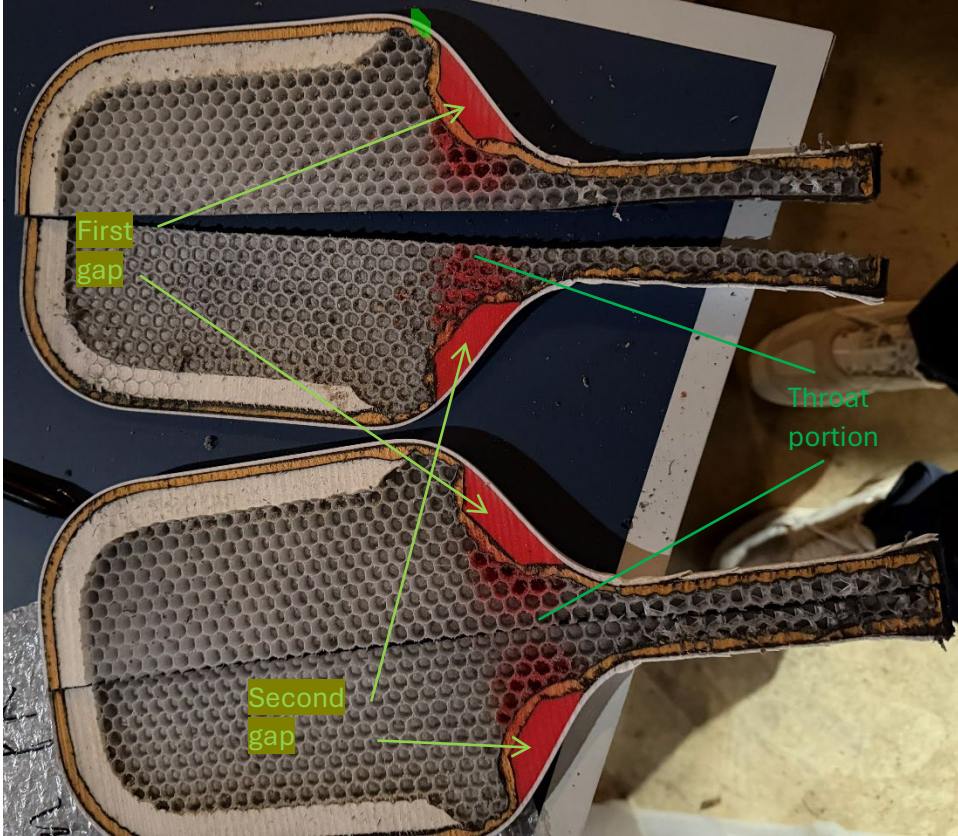
| | U.S. Patent No. 12,357,891 | RPM Friction Pro |
|--------------------|--|---|
| | <p>a first gap of the at least two gaps disposed on a first side of the paddle substantially adjacent to a throat portion thereof, and a second gap of the at least two gaps disposed on a second side of the paddle substantially adjacent to the throat portion thereof;</p> | <p>at least two gaps disposed on a first side of the paddle substantially adjacent to a throat portion thereof, and a second gap of the at least two gaps disposed on a second side of the paddle substantially adjacent to the throat portion thereof:</p>  <p>The photograph shows two cross-sections of a paddle. The top paddle has a label 'First gap' pointing to a gap on its left side. The bottom paddle has a label 'Second gap' pointing to a gap on its right side. A label 'Throat portion' points to the narrow neck area of both paddles. The paddles have a honeycomb-like internal structure and a red-colored outer layer.</p> |
| <p>26.e</p> | <p>a first filler disposed within one or more of the first gap and the second gap; and</p> | <p>The RPM Friction Pro Paddle includes a first filler disposed within one or more of the first gap and the second gap:</p> |

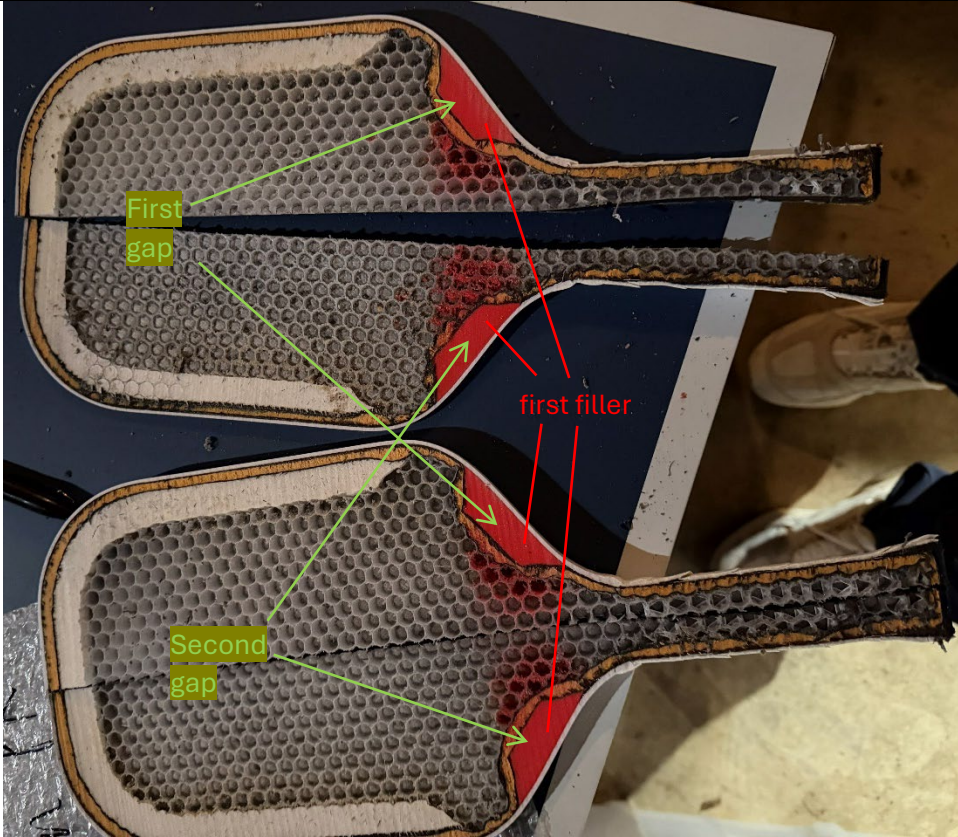
| | U.S. Patent No. 12,357,891 | RPM Friction Pro |
|--------------------|---|--|
| | |  <p>The photograph shows two paddle cores, one above the other, illustrating the internal structure. The cores are made of a honeycomb material. A red material, labeled 'first filler', is applied to the inner surface of the paddle. Two green arrows point to the 'First gap' and 'Second gap' between the paddle core and the frame. The 'first filler' is shown filling the gaps between the paddle core and the frame.</p> |
| <p>26.f</p> | <p>a frame disposed between the first surface and the second surface, wherein the frame is accommodated by the first gap and the second gap via the frame</p> | <p>The RPM Friction Pro Paddle includes a frame disposed between the first surface and the second surface, wherein the frame is accommodated by the first gap and the second gap via the frame</p> |

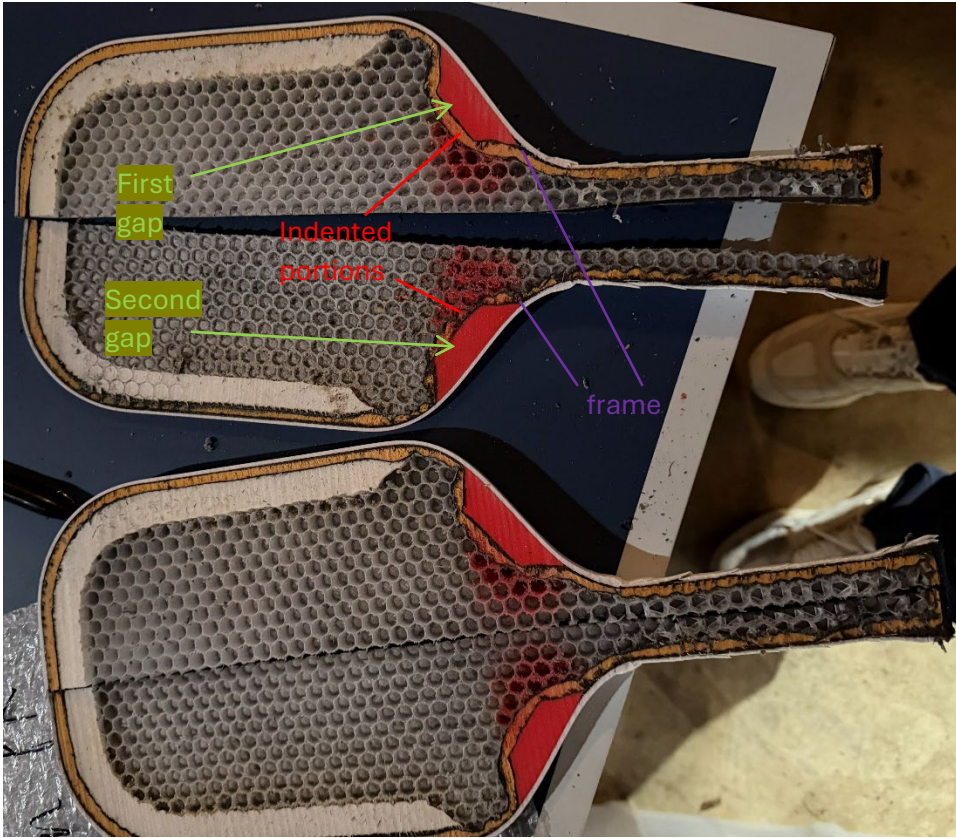
| | <p>U.S. Patent No. 12,357,891</p> | <p>RPM Friction Pro</p> |
|--|---|---|
| | <p>including one or more indented portions that are accommodated by the first gap and the second gap.</p> | <p>including one or more indented portions that are accommodated by the first gap and the second gap.</p>  |

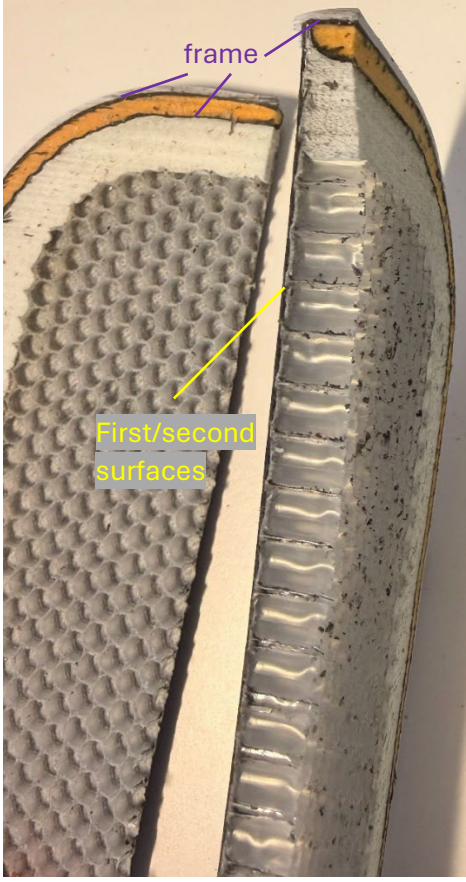
| | U.S. Patent No. 12,357,891 | RPM Friction Pro |
|--|----------------------------|--|
| | |  <p>A photograph showing a cross-section of a shoe sole. The sole is divided into two main parts. The left part is a thick, porous, grey material with a honeycomb-like structure. The right part is a thinner, grey material with a series of horizontal ridges or grooves. A purple label 'frame' points to the top edge of the sole. A yellow label 'First/second surfaces' points to the interface between the porous material and the ridged material.</p> |